

Ersatzteilliste-Explosionszeichnung

Elektro-Fritteuse EF9 / 1VB-23L-U1FT-S

[Art. 406392337]



SPARE PARTS CATALOGUE
CATALOGO PARTI DI RICAMBIO

FRIGGITRICI ELETTRICHE 23Lt E900 XP
ELECTRIC FRYERS 23Lt E900 XP

NEW PNC	DESCRIPTION	VOLT	REF
391337	23LT EL.FRYER-1 WELL+2 1/2 BASKETS	380-415	A
391380	23LT EL.FRYER-1 WELL+2 1/2 BASKETS-SOLAS-400V	400	B
391381	23LT EL.FRYER-1 WELL+2 1/2 BASKETS-SOLAS-440V	440	C
391384	23LT EL.FRYER-1 WELL+2 1/2 BASKETS-430V	415-430	D
391338	23+23LT EL.FRYER-2 WELLS+4 1/2 BASKETS	380-415	E
391382	23+23LT EL.FRYER-2 WELLS+4 1/2 BASKETS-SOLAS-	400	F
391383	23+23LT EL.FRYER-2 WELLS+4 1/2 BASKETS-SOLAS-	440	G
391385	23+23LT EL.FRYER-2 WELLS+4 1/2 BASKETS-430V	415-430	H
392337	23LT EL.FRYER-1 WELL+2 1/2 BASKETS	380-415	I
392384	23LT EL.FRYER-1 WELL+2 1/2 BASKETS-430V	415-430	J
392338	23+23LT EL.FRYER-2 WELLS+4 1/2 BASKETS	380-415	K
392385	23+23LT EL.FRYER-2 WELLS+4 1/2 BASKETS-430V	415-430	L
393337	23LT EL.FRYER-1 WELL+2 1/2 BASKETS	380-415	M
393384	23LT EL.FRYER-1 WELL+2 1/2 BASKETS-430V	415-430	N
393338	23+23LT EL.FRYER-2 WELLS+4 1/2 BASKETS	380-415	O
393385	23+23LT EL.FRYER-2 WELLS+4 1/2 BASKETS-430V	415-430	P

Index

General componets / Componenti struttura
Well components / Componenti vasca
Spare parts list / Liste ricambi

Page 2
Page 3
Page 4,5

Bold = Last change
Grassetto= Ultima modifica

Ed. page revision 2018 - 10

FRIGGITRICI ELETTRICHE 23Lt E900 XP
 ELECTRIC FRYERS 23Lt E900 XP

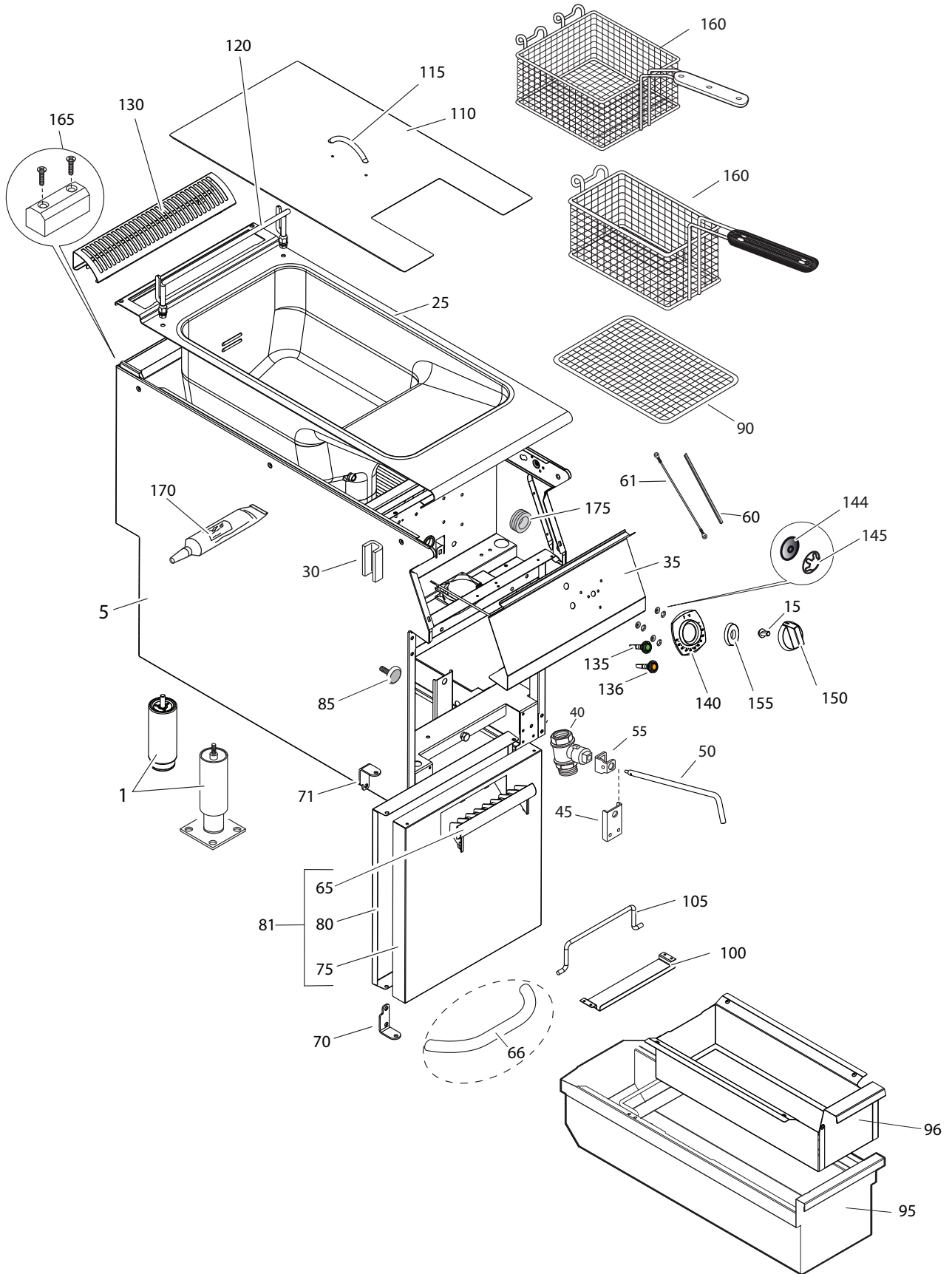

FRIGGITRICI ELETTRICHE 23Lt E900 XP
 ELECTRIC FRYERS 23Lt E900 XP

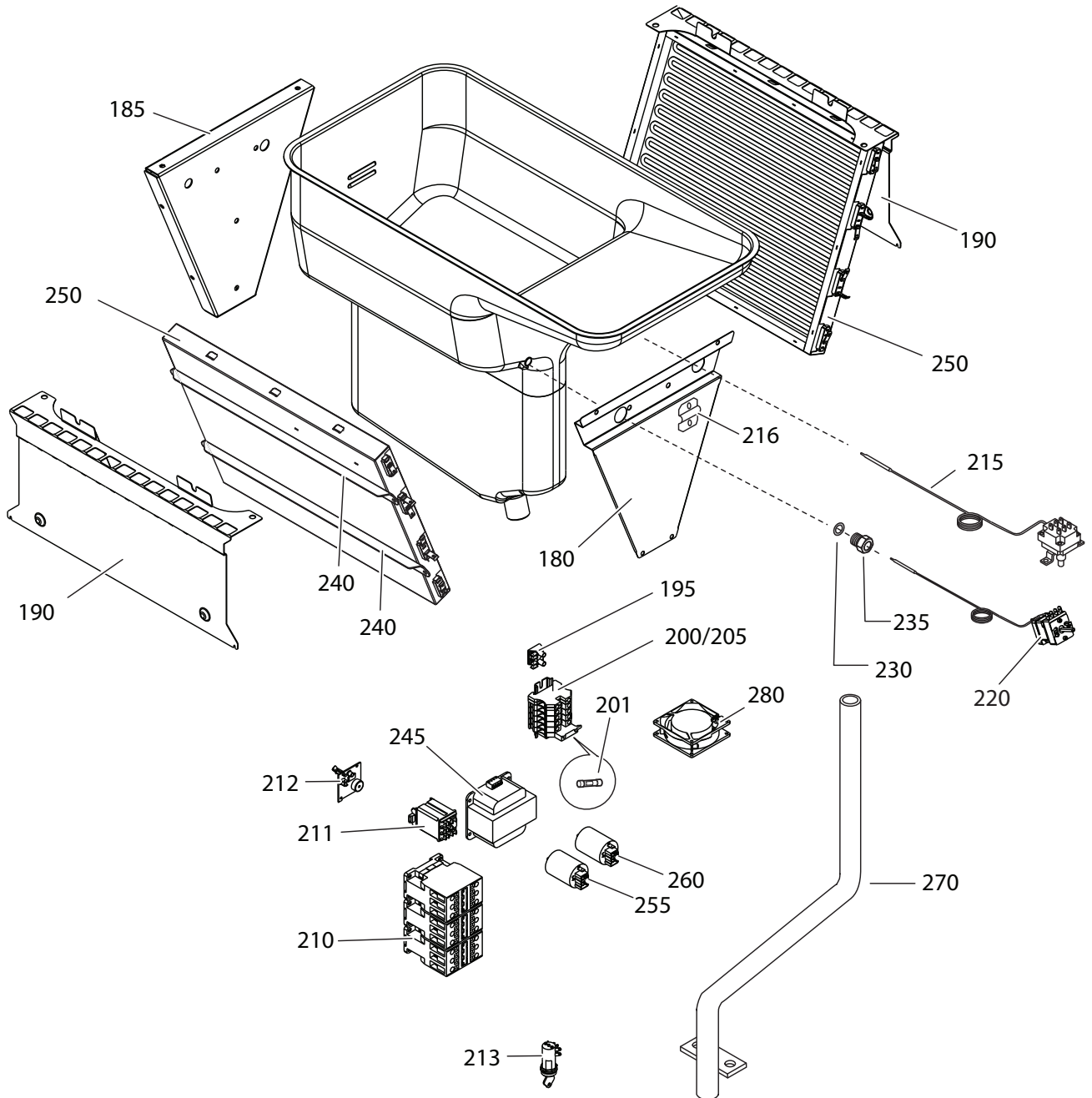

FRIGGITRICI ELETTRICHE 23Lt E900 XP
ELECTRIC FRYERS 23Lt E900 XP

FRIGGITRICI ELETTRICHE 23Lt E900 XP
ELECTRIC FRYERS 23Lt E900 XP

Pos	Spare part Code	Factory Code	Descrizione	Description	Ref./Note
1	0C0204	835856901	PIEDE	FOOT	A, D, E, H, I, J, K, L, M, N, O, P
	0C3324	806844600	PIEDE CON FLANGIA	FOOT WITH BASE	B, C, F, G
5	0CA526	85089DY02	ASS. FASCIA MONOBLOCCO 400 mm	ASSEMBLY BAND 400 mm	A, B, C, D
5	0C9010	85089DZ02	ASS. FASCIA MONOBLOCCO 800 mm	ASSEMBLY BAND 800 mm	E, F, G, H
5	0CB643	85089F302	ASS. FASCIA MONOBLOCCO 400 mm	ASSEMBLY BAND 400 mm	I, J, M, N
5	0C8984	85089F402	ASS. FASCIA MONOBLOCCO 800 mm	ASSEMBLY BAND 800 mm	K, L, O, P
10	0C6171	541813800	RONDELLA SILICONE	SILICONE WASHER	
15	0C7345	548877V00	ADTTATORE MANOPOLA	KNOB ADAPTER	A, B, C, D, E, F, G, H
25	0CB754	50389MS01	RIPIANO / VASCA 400mm	WORKTOP / TANK 400mm	A, B, C, D
		50389MW01	RIPIANO / VASCA 800mm	WORKTOP / TANK 800mm	E, F, G, H
		50389R402	RIPIANO / VASCA 400mm	WORKTOP / TANK 400mm	I, J, M, N
		50389R502	RIPIANO / VASCA 800mm	WORKTOP / TANK 800mm	K, L, O, P
30	0C0156	527850500	PIASTRA FISSAGGIO FIANCHI	SIDE PANEL JOINTING PLATE	
35	0C7740	85589AK02	CRUSCOTTO 400mm	CONTROL PANEL 400mm	A, D
	0C7741	85589AL02	CRUSCOTTO 800mm	CONTROL PANEL 800mm	E, H
	0C7517	87089J601	CRUSCOTTO 400mm	CONTROL PANEL 400mm	I, J
	0C7516	87089J101	CRUSCOTTO 800mm	CONTROL PANEL 800mm	K, L
	0C7523	50389N801	CRUSCOTTO 400mm	CONTROL PANEL 400mm	A, D, I, J, M, N
	0C7524	50389N901	CRUSCOTTO 800mm	CONTROL PANEL 800mm	E, H, K, L, O, P
40	006688	835855000	VALVOLA SCARICO	DRAIN VALVE	
45	*	50589K700	SUPPORTO LEVA SCARICO	SUPPORT, DRAIN EXTENSION	
50	0C0608	516868800	PROLUNGA LEVA SCARICO	DRAIN EXTENSION HANDLE	
55	006877	508897004	CONNESSIONE PROLUNGA SCARICO	CONNECTION, DRAIN EXTENSION	
60	0C2496	543821900	GUARNIZIONE - GRIGIA	GRAY GASKET	SPONGE 6X2MM
61	0C7366	830825901	CAVETTO SOSTEGNO CRUSCOTTO	SUPPORT CABLE, CONTROL PANEL	
65	0C8769	54887AH00	MANIGLIA	HANDLE	A, B, C, D, E, F, G, H
66	0C8190	54887A802	MANIGLIA	HANDLE	I, J, K, L
	0A5021	854864203	MANIGLIA	HANDLE	M, N, O, P
70	0C0138	516860801	CERNIERA INFERIORE	HINGE, LOWER	
71	0C0139	516860901	CERNIERA SUPERIORE	HINGE, UPPER	
75	0C7157	50389G300	PORTA	DOOR	A, B, C, D, E, F, G, H, I, J, K, L
	*	50389MB01	PORTA	DOOR	M, N, O, P
80	0C7158	50489CQ00	CONTROPORTA	INNER DOOR	
81	0C7163	85589CT03	ASS.PORTINA +MANIGLIA	COMPLETE DOOR WITH HANDLE	A, B, C, D, E, F, G, H
	0C7165	85589CU05	ASS.PORTINA+MANIGLIA	COMPLETE DOOR WITH HANDLE	I, J, K, L
	0C7627	85589CV02	ASS.PORTINA+MANIGLIA	COMPLETE DOOR WITH HANDLE	M, N, O, P
85	0C0201	830898201	MAGNETE PER PORT A	MAGNET, DOOR	
90	006130	830884701	GRIGLIA FONDO	BOTTOM GRILL	
91	006133	850894500	CESTELLO	BASKET	
95	0CB342	87589FL01	BACINELLA OLIO COMPLETA	COMPLETE BASIN FOR OIL	
96	0CB343	85589HC01	FILTRO OLIO (CASSETTINO)	OIL FILTER (SMALL TRAY)	
100	0C0612	528822801	SUPPORTO MANIGLIA	SUPPORT, HANDLE BASIN	
105	006131	516849501	MANIGLIA BACINELLA	HANDLE, BASIN	
110	0C0613	529890101	COPERCHIO FRIGGITRICE 23Lt	LID, FRYER 23Lt	
115	0C0614	511819000	MANIGLIA COPERCHIO	HANDLE, LID	
120	006583	516847804	SUPPORTO CESTELLI	SUPPORT, BASKET	
130	0C7333	50389LP00	GRIGLIA CAMINO	GRID	
135	005010	876800002	LAMPADA SPIA VERDE	LAMP; GREEN	
136	005011	876800102	LAMPADA SPIA ARANCIO	LAMP; ORANGE	
140	0C7481	548877L00	GHIERA	RING, KNOB	A, B, C, D, E, F, G, H

FRIGGITRICI ELETTRICHE 23Lt E900 XP
ELECTRIC FRYERS 23Lt E900 XP

FRIGGITRICI ELETTRICHE 23Lt E900 XP
ELECTRIC FRYERS 23Lt E900 XP

Pos	Spare part Code	Factory Code	Descrizione	Description	Ref./Note
144	0C7485	548879W00	GHIERA	RING, KNOB	I, J, K, L, M, N, O, P
145	0C6171	0541813800	RONDELLA SILICONE	SILICONE WASHER	
150	069567	218912211	ANELLO DI FISSAGGIO GHIERA	SPRING, KNOB RING	
	0C6670	511850G01	MANOPOLA	KNOB	A, B, C, D, E, F, G, H
	0C7232	548878201	MANOPOLA	KNOB	I, J, K, L
	0A5621	548865500	MANOPOLA	KNOB	M, N, O, P
155	053816	543821000	GUARNIZIONE PER MANOPOLA	GASKET, KNOB	E, F, G, H, K, L, O, P
160	006133	850894500	CESTELLO ½ MODULO	ONE BASKET 1/2	23lt
	006539	878824600	CESTELLO 1 MODULO INTERO	FULL SIZE BASKET	23+23lt
165	0C0137	516860702	PIASTRA GIUNZIONE APPARECC.	JOINTING REAR PLATE	
170	006083	147098044	ADESIVO SILICONICO gr.100	ADHESIVE PIPE gr.100	
175	050180	246520500	PASSACAVO DIA.23	CABLE GROMMET DIA.23	
180		50489WX00	SUPPORTO ANT. RESISTENZA	FRONT SUPPORT, HEATING ELEM.	
185		50489V000	SUPPORTO POST. RESISTENZA	REAR SUPPORT, HEATING ELEM.	
190		50489V100	SUPPORTO SUPERIORE RESIST.	UPPER SUPPORT, HEATING ELEM.	
195		639400700	MORSETTIERA	TERMINAL BOARD	B, C, F, G
200	0C4759	639811900	MORSETTIERA+PORTA FUSIBILE	TERMINAL BOARD + FUSE HOLDER	A, D, I, J, M, N
201	054456	652800100	FUSIBILE MORSETTIERA 5x20 1A	FUSE, TERMINAL BOARD 5x20 1A	A, D, I, J, M, N
205	006854	639806600	MORSETTIERA 16MM	TERMINAL BOARD 16MM	B, C, E, F, G, H, K, L, O, P
210	007080	648807700	CONTATTORE 32A 230V	CONTACTOR 32A 230V	
	007080	648807700	CONTATTORE 18A 230V	CONTACTOR 18A 230V	D,H,J,L,N,P
211	006610	648806900	RELE	RELAY	B, C, F, G
212	*	675401000	SCHEDA BUZZER	BUZZER , BOARD	B, C, F, G
213	*	80589DW00	BLOCCHETTO CHIAVE SOLAS	LOCK AND KEY SOLAS	B, C, F, G
215	005941	646810002	TERMOSTATO DI SICUREZZA	SAFETY THERMOSTAT	
216	0C4749	527871901	SUPPORTO BULBO LIMITATORE	SUPPORT SAFETY THERMOSTAT	
220	052330	446578713	INTERRUTT. CON TERMOSTATO	SWITCH WITH THERMOSTAT	
230	059293	543815000	GUARNIZIONE OR	OR GASKET RING	
235	059295	514874500	PREMISTOPPA	BULB STOPPER	
240	*	50589KR00	SUPPORTO FASCIA, RESISTENZA	STRAPPER H.ELEMENT	
245	006710	0624806700	AUTOTRASFORMATORE 0-240-400-440V 150VA	VOLTAGE ADAPTOR	B, C, F, G
250	006158	617821806	RESISTENZA; 9000 W-400V	HEATING ELEMENT; 9000 W-400V	A, B, E, F, I, K, M, O
	0CB356	61783AK01	RESISTENZA; 9000 W-440V	HEATING ELEMENT; 9000 W-440V	C, D, G, H, J, L, N, P
255	049303	694605400	FILTRO RFI, TRIFASE	THREEFASE RADIO INTERFERENCE FILTER	A, D, E, H, I, J, K, L, M, N, O, P
260	0CB477	694400U00	FILTRO RFI, MONOFASE	SINGLE FASE R.I.FILTER	A, D, E, H, I, J, K, L, M, N, O, P
270	*	85589H100	ENTRATA CAVO ELETTRICO 400mm	ELECT. CABLE INLET 400mm	A, B, C, D, I, J, M, N
	*	85589H700	ENTRATA CAVO ELETTRICO 800mm	ELECT. CABLE INLET 800mm	E, F, G, H, K, L, O, P
280	006125	624806302	MOTO VENTILATORE	MOTORVENTILATOR	E, F, G, H, K, L, O, P
*	0CB471	*	KIT MANUTENZIONE FRIGGITRICI ELETTRICHE 15/23LT E700/E900	E700/E900 15/23LT ELECTRIC FRYER MAINTENANCE KIT	23LT 380-415V A-I-M (60+135+230+235)
*	0CB472	*	KIT MANUTENZIONE FRIGGITRICI ELETTRICHE 2x15/23LT E700/E900	E700/E900 2x15/23LT ELECTRIC FRYER MAINTENANCE KIT	2x23LT 380-415V E-K-O (60+2x135+2x230+2x235)



Electrolux Professional SPA
Viale Treviso 15
33170 Pordenone
www.electrolux-professional.com

NordCap GmbH & Co. KG
Thalendorststraße 15
28307 Bremen
Hauptsitz (Service, Finanzen & Personal, Lager, IT, Marketing)

Telefon: +49 421 48557-0
Telefax: +49 421 488650
E-Mail: bremen@nordcap.de

Die NordCap Verkaufsniederlassungen in Deutschland:

Nord: Hamburg • Ost: Berlin • Süd: Ingelheim • West: Erkrath

by **NordCap**[®]

ZANUSSI
PROFESSIONAL