

Ersatzteilliste-Explosionszeichnung Pizzateig Presse iP5 45 - iRoll

[Artikel-Nr.: 493030150]

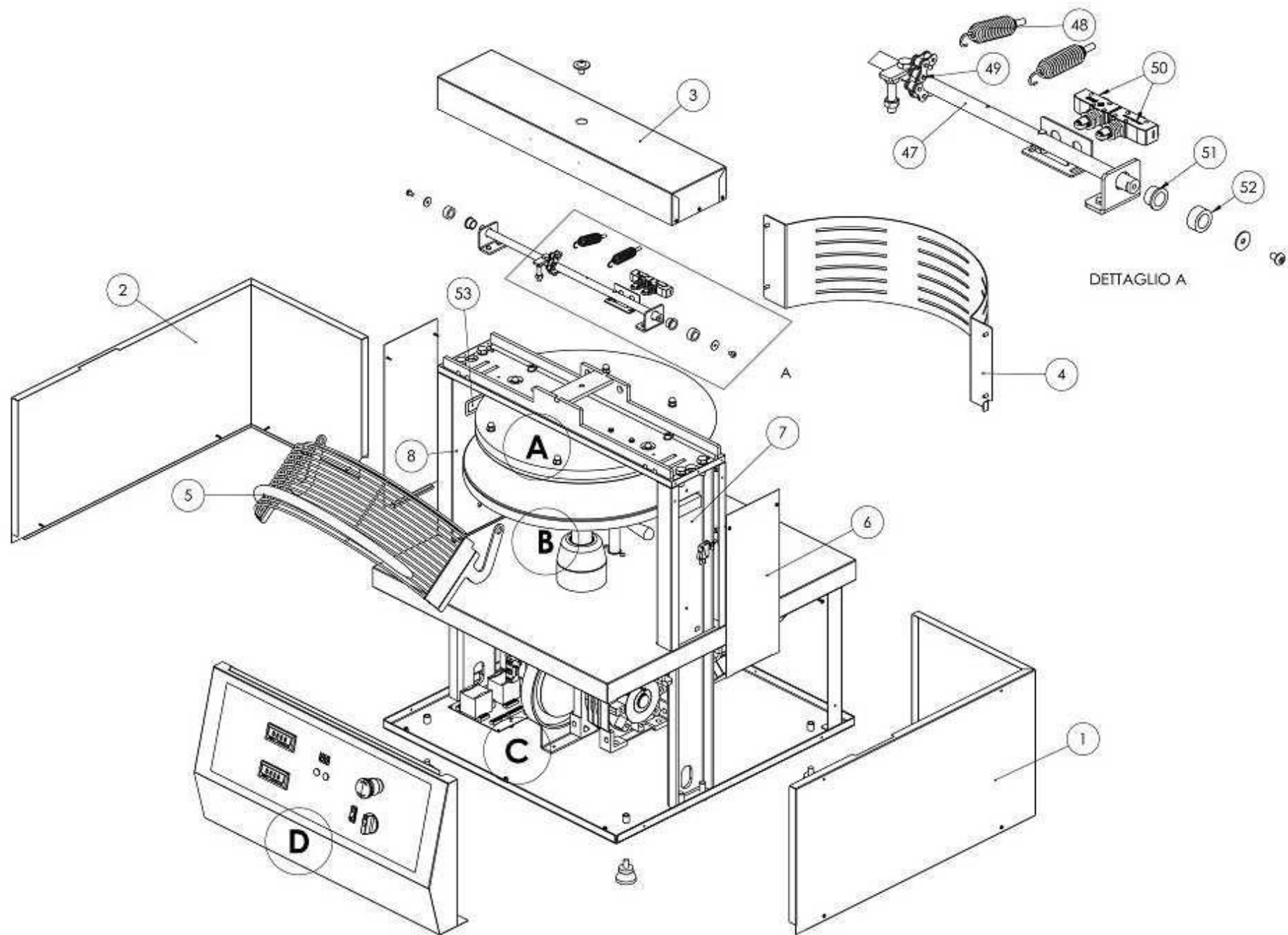

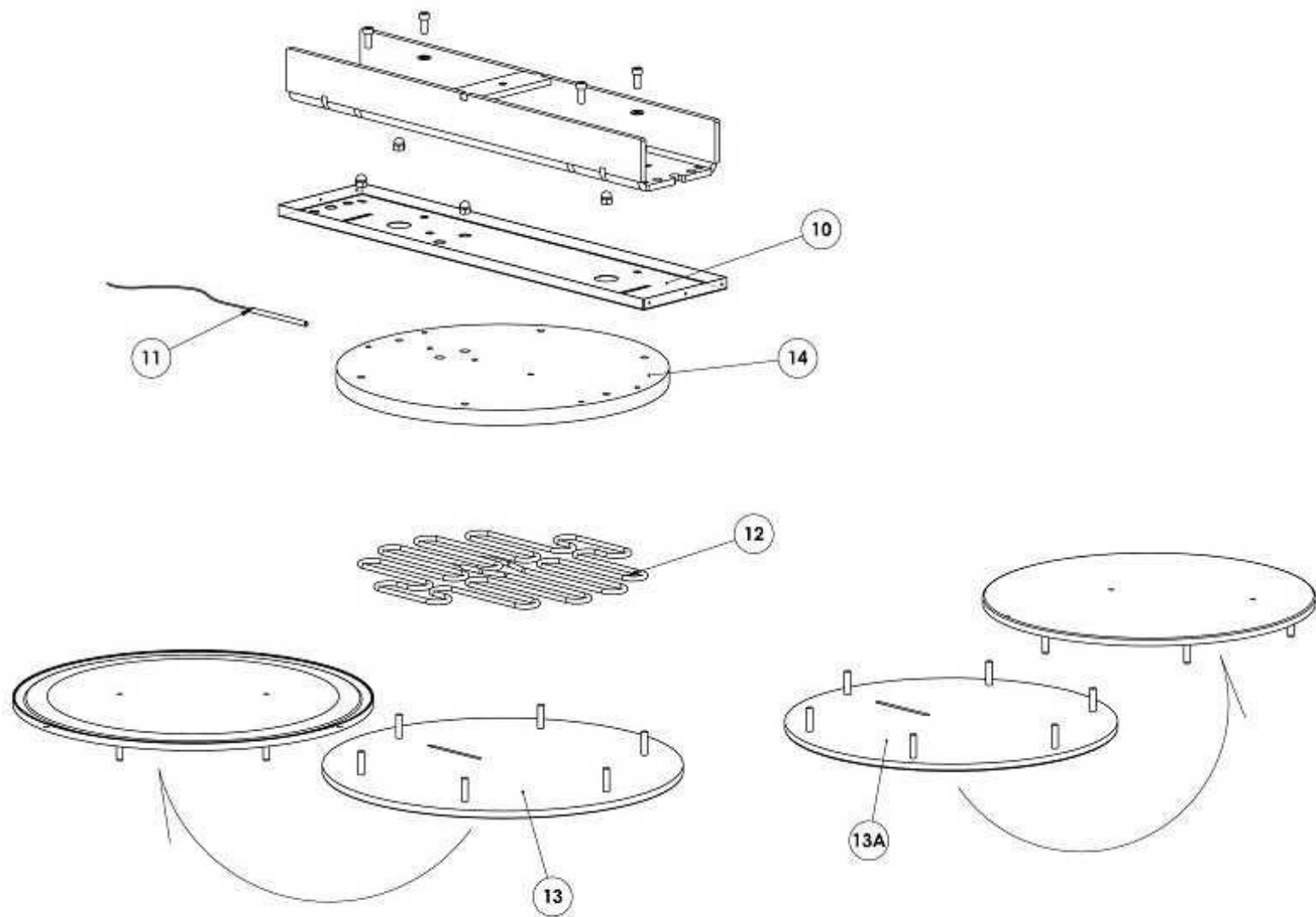



PART. "B"

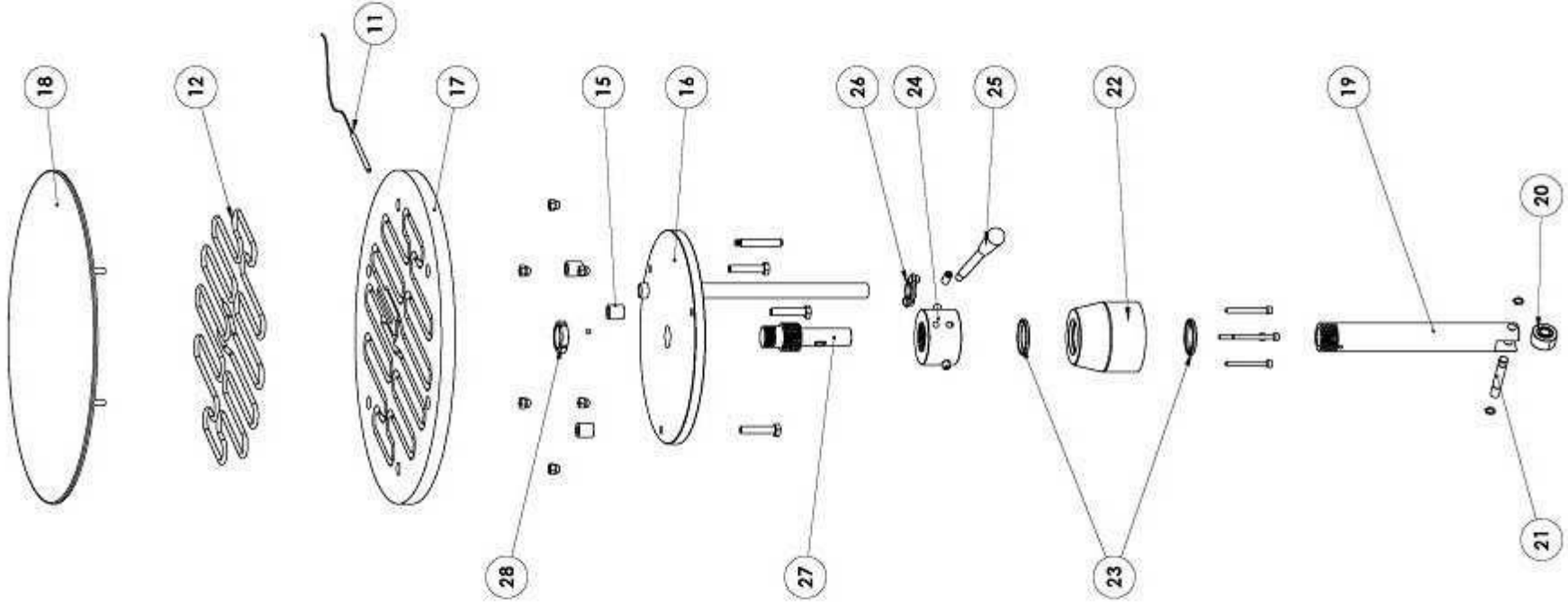

PART. "C" SINGLE-PHASE

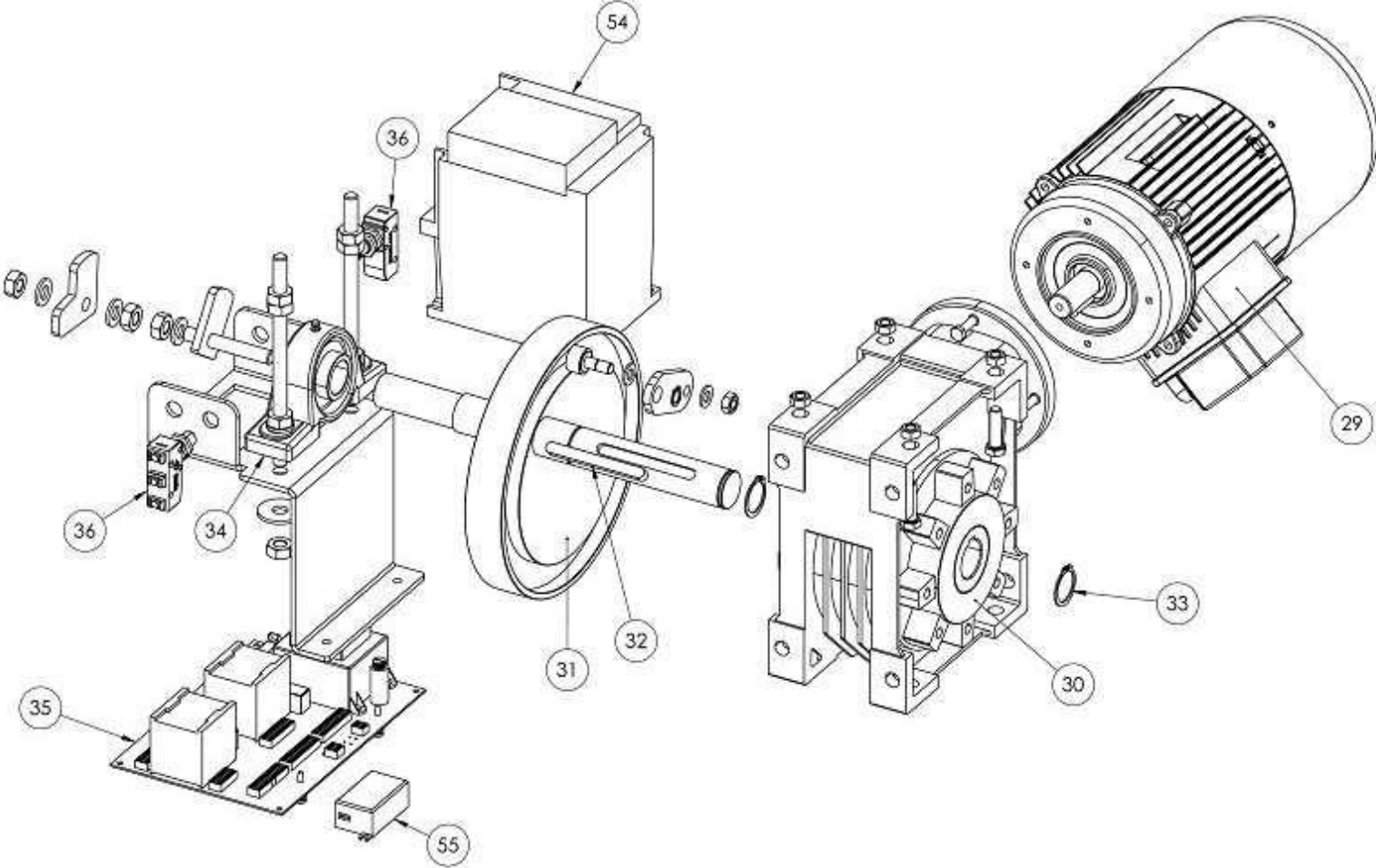

PART. "C" THREE-PHASE

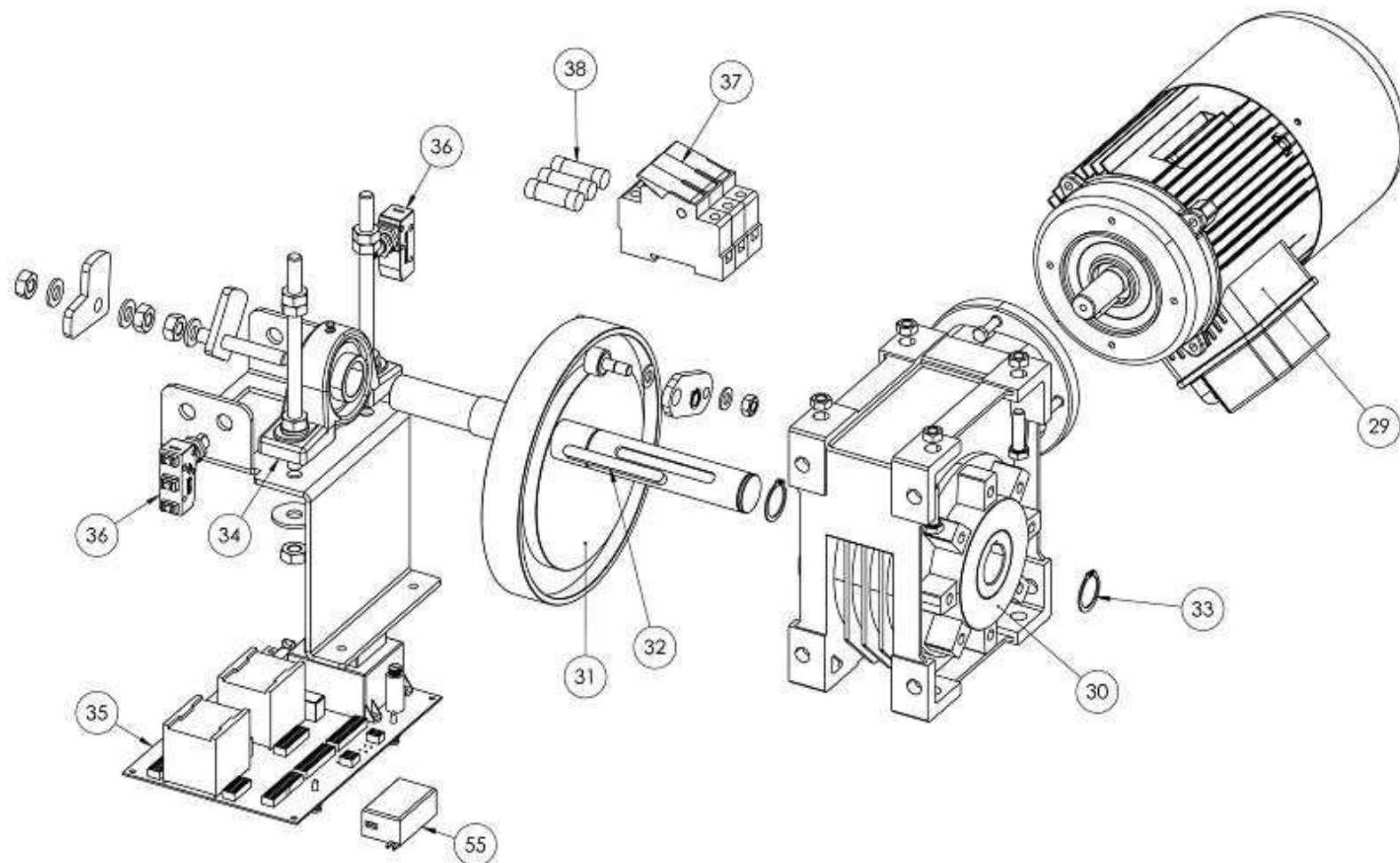

PART. "D"

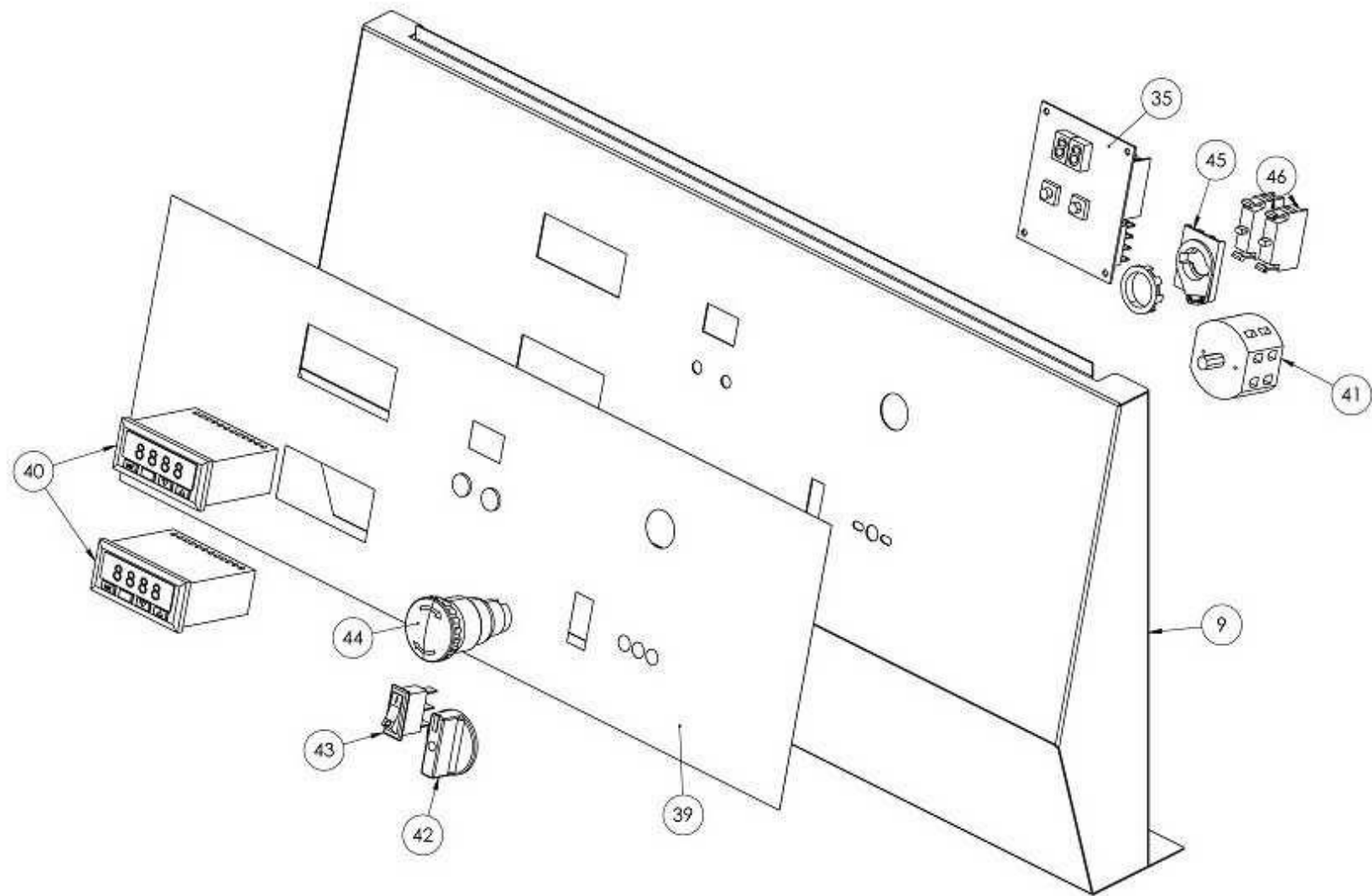

Rf.	Denominazione	Designation	Denominación	Denomination	Bezeichnung
1	Pannello laterale destro	Right side panel	Panel lateral derecho	Panneau latéral droit	Rechtes Seitenteil
2	Pannello laterale sinistro	Left side panel	Panel lateral izquierdo	Panneau latéral gauche	Linke Seitenwand
3	Copertura superiore	Top cover	La cubierta superior	Le couvercle supérieur	Obere Abdeckung
4	Copertura posteriore	Back cover	Contraportada	Quatrième de couverture	Rückseite
5	Griglia protezione	Protection grid	Rejilla de protección	Grille de protection	Schutzgitter
6	Copertura esterna colonna	External column cover	Cubierta de columna externa	Couvercle de colonne externe	Externe Säulenabdeckung
7	Copertura interna destra colonna	Right column internal cover	Cubierta interna columna derecha	Couverture interne de la colonne droite	Innenabdeckung der rechten Säule
8	Copertura interna sinistra colonna	Left column internal cover	Cubierta interna columna izquierda	Couvercle interne de la colonne de gauche	Innenabdeckung der linken Säule
9	Pannello comandi	Control panel	Panel de control	Panneau commande	Schalttafel
10	Fondo sostegno superiore	Upper support bottom	Base de apoyo superior	Support supérieur bas	Obere Stütze unten
11	Sonda	Probe	Sonda	Sonde	Sonde
12	Resistenza	Resistance	Resistencia	Resistance	Widerstand
13	Piatto superiore con bordo	Top plate with edge	Placa superior con borde	Assiette supérieure avec bord	Oberste Platte mit Rand
13A	Piatto superiore piano	Flat top	Plato superior plano	Plateau supérieur étage	Obere Platte flach
14	Sottopiatto superiore	Topplate	Placa superior	Sous-terrain supérieur	Großes Platzteller
15	Distanziale piatto inferiore	Bottom plate spacer	Espaciador plano inferior	Entretoise plate inférieure	Distanz flacher Teller unten
16	Disco sostegno piatto inferiore	Bottom plate support disc	Disco de soporte plano inferior	Disque de soutien plat inférieur	Flache Platte unten
17	Sottopiatto inferiore	Lower platter	Placa inferior	Sous-terrain inférieur	Platzhalter unten
18	Piatto inferiore	bottom plate	chapa fonda	Plat inférieur	Untere Platte
19	Albero piatto inferiore	Lower flat shaft	Árbol plano inferior	Arbre plat inférieur	Flacher Baum unten
20	Cuscinetto	Bearing	Cojinete	Roulement	Lager
21	Perno albero	Shaft pin	Eje de pivote	Pivot d'arbre	Wellenzapfen
22	Boccola guida albero	Shaft guide bushing	Casquillo guía árbol	Douille guide arbre	Baumstamm in der Buchse
23	Anello di tenuta	sealing ring	anillo de sellado	bague d'étanchéité	Ring zum Binden von
24	Ghiera piatto	Flat ring	Anillo plano	Bague plate	flacher Ring
25	Braccio regolazione piatto	Flat adjustment arm	Bras de ajuste plano	Bras de réglage plat	Schwenkarm mit flachem Regler
26	Boccola flangiata a due fori	Flanged bushing with two holes	Casquillo de brida de dos orificios	Douille à deux trous	Flansch mit zwei Löchern
27	Albero regolazione piatti	Shaft adjustment plates	Eje de ajuste plano	Arbre de réglage plats	Verstellbare Welle mit flachem Ende
28	Ghiera	Ring nut	Virola	bague	Zwinge
29	Motore	Motor	Motor	Moteur	Motor
30	Riduttore	reducer	reductor	réducteur	Untersetzungsgetriebe
31	Camma	cam	leva	came	Nocken
32	Linguetta	Tongue	Lingua	Languette	Lasche
33	Seeger	Segers	Seeger	Seeger	Seeger
34	Supporto cuscinetto	bearing support	Soporte de cojinete	palier support	Stütze für die Polsterung
35	Scheda di potenza	power board	Tarjeta de alimentación	Carte de puissance	Karteikarte für die Leistung
36	Micro a pulsante	Button micro	Micro de botón	Micro à bouton-poussoir	Micro auf Knopfdruck
37	Portafusibile	fuse holder	portafusible	porte-fusible	Sicherungshalter
38	Fusibile	Fuse	Fusible	Fusible	Sicherung
39	Etichetta	Label	Tarjeta	Etiquette	Etikett-
40	Termostati	Thermostats	termostatos	Thermostats	Thermostate
41	Interruttore generale	general switch	interruptor general	interrupteur général	Hauptkontrollschalter
42	Manopola interruttore generale	Master switch knob	Botón de interruptor principal	Bouton interrupteur général	Regler für den Hauptschalter
43	Interruttore luce	Light switch	Interruptor de la luz	Interrupteur lumière	Lichtschalter
			73304070	iPs 33 – 45	Pag.1/2

Finanzen/Service
28307 Bremen
Thalendorststraße 15
Tel.+49 421 48557-0
Fax+49 421 488650
bremen@nordcap.de

Vertrieb Ost
12681 Berlin
Wolfener Straße 32/34, Haus K
Tel.+49 30 936684-0
Fax+49 30 936684-44
berlin@nordcap.de

Vertrieb West
40699 Erkrath
Max-Planck-Straße 30
Tel.+49 211 540054-0
Fax+49 211 540054-54
erkrath@nordcap.de

Vertrieb Nord
21079 Hamburg
Großmoorbogen 5
Tel.+49 40 766183-0
Fax+49 40 770799
hamburg@nordcap.de

Vertrieb Süd
55218 Ingelheim
Hermann-Bopp-Straße 4
Tel.+49 6132 7101-0
Fax+49 6132 7101-20
ingelheim@nordcap.de



www.nordcap.de