

Ersatzteilliste-Explosionszeichnung

Schnellkühler / Schockfroster SF 80/40-CW CRIO CHILL



INDEX - INDICE

PAG.

CABINET AND DOOR	3
SPARE PART LISTS - CABINET AND DOOR	4
COOLING UNIT AND CONTROL PANEL	5
SPARE PART LISTS - COOLING UNIT AND CONTROL PANEL	6

POS	FACTORY CODE	S.P. CODE	DESCRIPTION	V	W&T	REF.	NOTES	S/N BREAK (YYYY/WK)
1	0830776603	085779	Top for freestanding appliance		x			
2	0505793102	090002	Horizontal frame	x				
3	0505783101	090003	Vertical frame	x				
4	0546R27300	093934	Plug for pipe		x			
4a	0546R25400	094255	Discharge pipe		x			
4b	0546R26900	094257	Nut		x			
4c	0546R26200	094256	Rubber support for pipe		x			
5	0514R32000	097710	Left shelf rack	x				
6	0514R32100	097711	Right shelf rack	x				
7	0640R00D00	097671	Door microswitch	x				
8	0242452410	080803	Water condenser basin		x			
9	0875R06L01	097699	Door assembly	x				
10	0543750202	083397	Door gasket	x				
11	0855631900	048579	Feet	x				
12	0506753502	085754	Upper hinge door	x				
13	0506753604	085755	Lower hinge door	x				
14	0506717801	0A9124	Door hinge pin	x				
15	0544709200	083875	Door hinge bush	x				
16	0835714501	083876	Door hinge lowered pin	x				
17	0805R01J02	097718	Control panel without components		x	b	EPR	
17	0805R01K01	097719	Control panel without components		x	a; c; d	ZAN, APX, TO BRAND	
18	0755R16800	097668	EPR control sticker	x		b	EPR	
18	0755R16900	097667	ZAN control sticker	x		a	ZAN	
18	0755R17001	097683	APX control sticker	x		d	APX	
18	0755R17100	097666	To brand control sticker	x		c	TO BRAND	
19	0512773002	097672	Control panel support		x			
20	0549703000	087955	Bush	x				
21	0514706702	082757	Pin for hinge	x				
22	0506755701	085778	Lower hinge	x				
23	0546703802	083878	Hook racks support	x				
24	0617727001	090001	Heating cable		x			
25	0646R06Z00	097682	One sensor food probe	x				
26	0875798302	090004	Middle support		x			
27	0505793000	090005	Middle support frame		x			
28	0545743001	085776	Panel gasket	x				
29	0855R0AS01	097723	Foamed panel		x			
30	0506775700	088120	Bracket for panel	x				

SPARE PARTS CODE - CABINET AND DOOR

* On demand

Bold=last change

From Ser. Nr. Up to Ser. Nr.	Ed. 01 2023-03 Ed. 01 2023-03	Page: 4	Doc No:595R07K00
---------------------------------	----------------------------------	---------	-------------------------

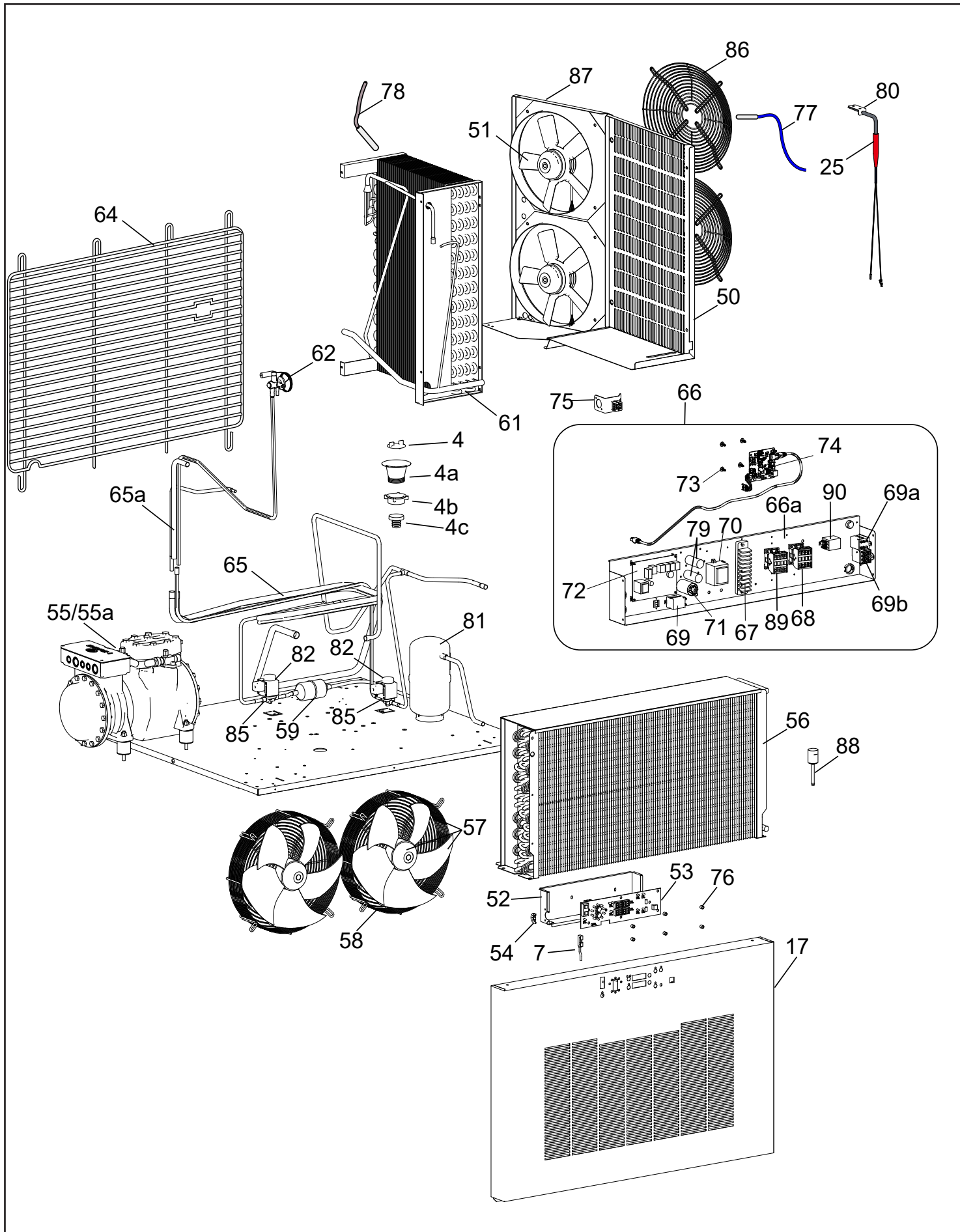

COOLING UNIT AND CONTROL PANEL

From Ser. Nr.
Up to Ser. Nr.

Ed. 01 2023-03
Ed. 01 2023-03

Page: 5 @

Doc No:595R07K00

POS	FACTORY CODE	S.P. CODE	DESCRIPTION	V	W&T	REF.	NOTES	S/N BREAK (YYYY/WK)
50	0502783603	097701	Evaporator carter		x			
51	0858733002	090014	Fan evaporator assembly	x				
52	0504R37400	097670	User board protection		x			
53	0648R02M00	097726	User board	x				
54	0639R23600	097673	Grommet	x				
55	0684731400	099916	Compressor TECUMSEH	x				
55a		097632	Krivan	x				
56	0830797902	090020	Gas condenser	x				
57	0856R26200	094830	Motor fan condenser ELCO 230-240V/50-60 HZ assembly	x				
58	0514R09700	092853	Protection fan condenser	x				
59	0805747600	087438	Filter DML052 S	x				
61	0845719904	090016	Evaporator	x				
62	0646754900	088347	Thermostatic valve/Expansion valve	x				
64	0541716802	090009	Back grid		x			
65	0525702101	097713	Pipe exchanger	x				
65a	0525702901	097714	Pipe exchanger prolong	x				
66	0855R0A701		Electric box assembly	x				
66a	0512734003	097706	Electric box	x				
67	0855R09W01	097722	Clamp with wiring	x				
68	0648807300	088477	Contacto 220-230 50 hz	x				
69	0648802701	056510	Relay Finder 24 V	x				
69a	0648703800	083215	Relay Finder 60.62.8.230	x				
69b	0648725400	088197	Relay RA	x				
70	0624711702	087662	Voltage adaptor 230/24 V	x				
71	0694700800	084987	Filter LC		x			
72	0648R04902	093125	Main board	x				
73	0546401600	095984	Main board spacer	x				
74	*	*	Lion board connectivity		x			
75	*	*	Connectivity bracket LAN cable		x			
76	0546R08D00	097674	Round spacer Ø 6,2 ; EX 9,0	x				
77	0646R07200	092177	Blu cell probe	x				
78	0646R12000	093531	Gray evaporator probe	x				
79	0648729500	090089	Capacitor 5 UF UL-CSA	x				
79	0648730000	096009	Capacitor 3 UF UL-CSA	x				
80	0510781500	094478	Food probe support		x			
81	0805725601	083468	Liquid receiver	x				
82	0646749000	088351	Coil for solenoid valve	x				
85	0646723000	084085	Solenoid valve	x				
86	0514752001	088623	Motor fan grid		x			
87	0502783502	097700	Fan evaporator carter		x			
88	0646R20300	096201	Pressure switch for high pressure	x				
89	0640R00600	091706	Safety switch for compressor	x				
90	0694701300	099146	Electric filter	x				

SPARE PARTS CODE - COOLING UNIT AND CONTROL PANEL

* On demand

Bold=last change

From Ser. Nr. Up to Ser. Nr.	Ed. 01 2023-03 Ed. 01 2023-03	Page: 6	Doc No:595R07K00
---------------------------------	----------------------------------	---------	-------------------------

Electrolux Professional SpA
Viale Treviso, 15
33170 Pordenone, ITALY
Fax (+39) 0434 380 201
<https://www.electroluxprofessional.com>
<https://webgate.electroluxprofessional.com>

Finanzen / Service
28307 Bremen
Thalendorststraße 15
Tel.+49 421 48557-0
Fax+49 421 488650
bremen@nordcap.de

Vertrieb Ost
12681 Berlin
Wolfener Straße 32/34, Haus K
Tel.+49 30 936684-0
Fax+49 30 936684-44
berlin@nordcap.de

Vertrieb West
40699 Erkrath
Max-Planck-Straße 30
Tel.+49 211 540054-0
Fax+49 211 540054-54
erkraht@nordcap.de

Vertrieb Nord
21079 Hamburg
Großmoorbogen 5
Tel.+49 40 766183-0
Fax+49 40 770799
hamburg@nordcap.de

Vertrieb Süd
55218 Ingelheim
Hermann-Bopp-Straße 4
Tel.+49 6132 7101-0
Fax+49 6132 7101-20
ingelheim@nordcap.de



www.nordcap.de