

## Ersatzteilliste-Explosionszeichnung Kühltisch (3 Abteile) CLO 650



# ECOSTORE CL & BL h650

Remote Connection

## Left side cooling unit

Type reference	Ref	Page	Description	Brand
H6FTN2R	a	3 to 14	Counter 2 compartments refrigerated	all
H6FTN3R	b	3 to 14	Counter 3 compartments refrigerated	all
H6FTN4R	c	3 to 14	Counter 4 compartments refrigerated	all

### Index

	Page
Identification Type Ref./Identificazione type Ref.	2
Body module/corpo tavolo	3
Spare part list/Lista ricambi	4
Cooling unit Refrig. /Gruppo Refrigerato	5
Spare part list/Lista ricambi	6
Top/Ripiano	7
Spare part list/Lista ricambi	8
Door and drawers/ Porte e cassetti	9-10
Spare part list/Lista ricambi	11
Control panel/Pannello di controllo	12
Spare part list/Lista ricambi	13

BL= Benefit line

CL = Concept line

Rev.2

From Ser. Nr.... Up to Ser. Nr....	Ed. 2018/02 Updated 2023/07	Page: 1	Doc No:595R41400
---------------------------------------	--------------------------------	---------	------------------

## How to put in relation the “Type Ref.” reported on the data plate with the “Type reference” reported on the front page of the Spare Part Catalogue:

The “Type Ref.” represents a group of models/brands all with similar technical features, hence possible to be reported under the same scheme in terms of exploded views.

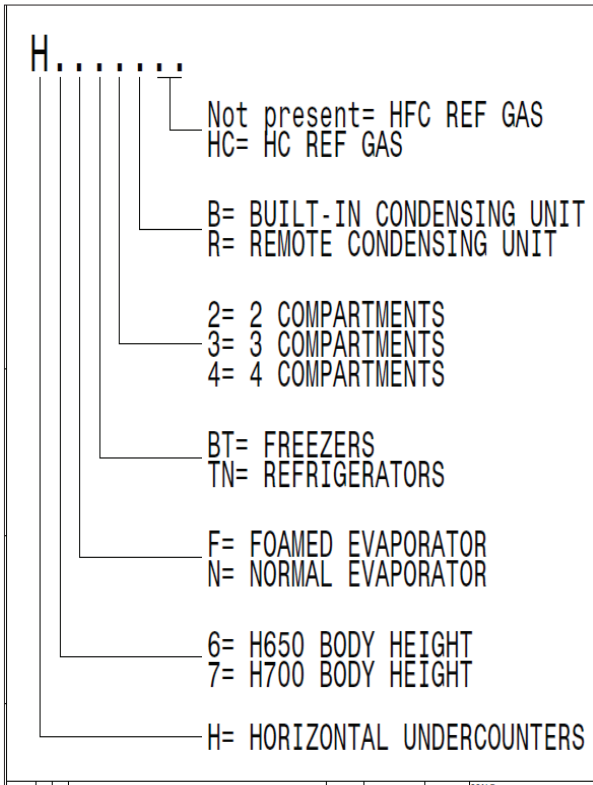

Find below an identification example: **H7NTN2BHC**

F. Mod. EH2H7AA	Comm. Mod. EH2H7AA	Type Ref. <b>H7NTN2BHC</b>	<b>2017</b>
PNC 9VTX 710000 00	Ser. No. 70810001	Cyclopentane	
W Tot. 0.25 kW	Volt 220-240 V	1 ~ 50 Hz	Total Current 1.9 A
Potenza Sbrinamento / Defrost Power	0.29 kW	Classe/Class 5	GWP 3 CO2-eq 0
Resistenza Evaporazione/Evaporation Heater El.	kW	Refrigerante / Refrigerant R290	0,07 kg.
Illuminazione / Lighting	W	Cap. 240	<b>MADE IN ITALY</b>
NF nominal Charge			
Rated Pressure	MPa		
IP21			
Electrolux Professional SpA - Viale Treviso, 15 - 33170 Pordenone (Italy)			

For the right spare code identification follow the steps:

- 1.Type in the website the PNC reported on the data plate.
- 2.The website will automatically display this spare part catalogue.
- 3.The spare part code at this point is referenced through the “Type reference” as from the front page by the relevant “Ref”.

## Come mettere in relazione il “Type Ref.” Riportato sulla targhetta caratteristica con il “Type reference” riportato sul frontespizio del catalogo ricambi:

Il “Type Ref.” Rappresenta un gruppo di modelli/marchi con simili caratteristiche tecniche, ossia possibili da rappresentare con il medesimo schema in termini di vista esplosa.

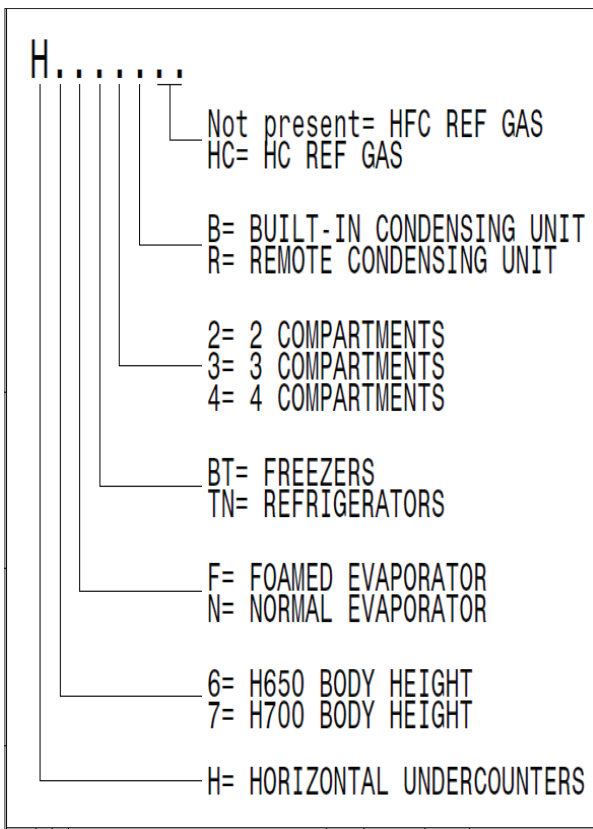

Qui di seguito un esempio di identificazione: **H7NTN2BHC**

Mod. EH2H7AA	Comm. Mod. EH2H7AA	Type Ref. <b>H7NTN2BHC</b>	<b>2017</b>
NC 9VTX 710000 00	Ser. No. 70810001	Cyclopentane	
Tot. 0.25 kW	Volt 220-240 V	1 ~ 50 Hz	Total Current 1.9 A
Potenza Sbrinamento / Defrost Power	0.29 kW	Classe/Class 5	GWP 3 CO2-eq 0
Resistenza Evaporazione/Evaporation Heater El.	kW	Refrigerante / Refrigerant R290	0,07 kg.
Illuminazione / Lighting	W	Cap. 240	<b>MADE IN ITALY</b>
NF nominal Charge			
Rated Pressure	MPa		
IP21			
Electrolux Professional SpA - Viale Treviso, 15 - 33170 Pordenone (Italy)			

**Per identificare il corretto codice ricambio procedere con:**

- 1.Digitare nel website il PNC riportato sulla targhetta caratteristica.
- 2.Il website mostrerà automaticamente questo catalogo ricambi.
- 3.A questo punto, il codice ricambio è identificabile attraverso il “Type reference” come indicato nel frontespizio sotto la relativa voce “Ref”.

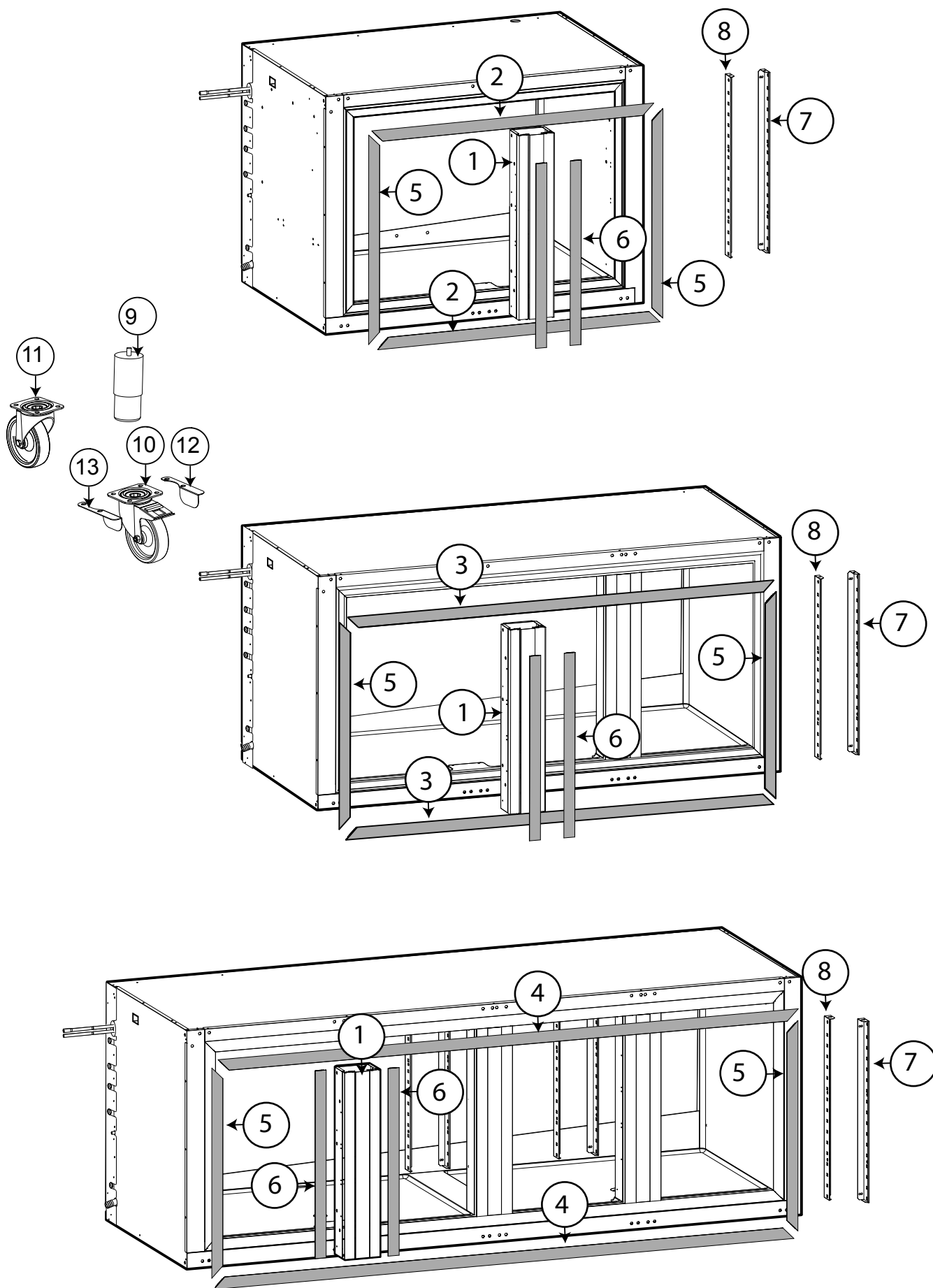



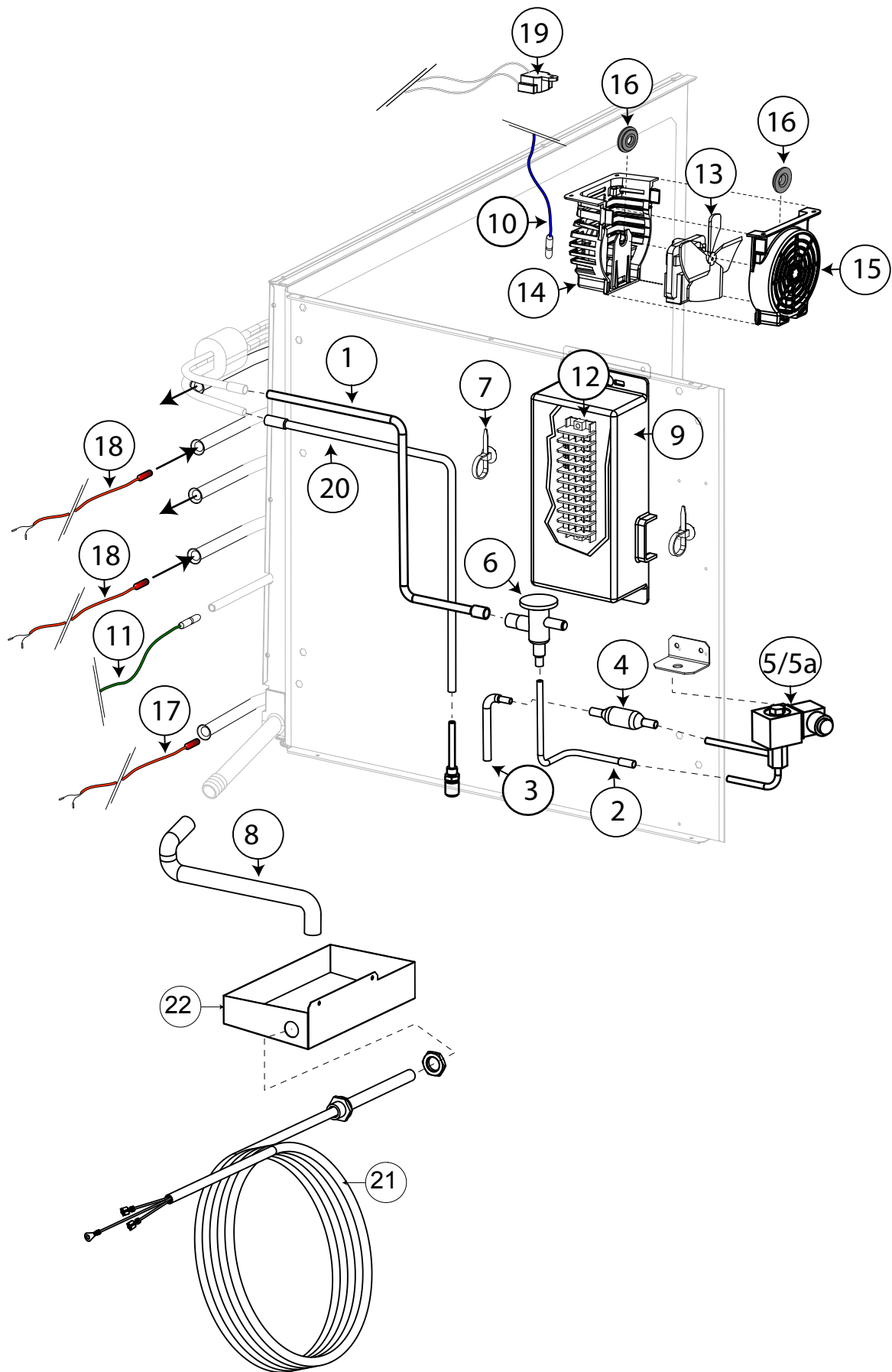

Pos	Code	Factory code	Description	Descrizione	Ref/notes
Pag. 5					
Cooling unit 2-3-4 comp. refrigerated			Gruppo 2-3-4 vani refrigerato		
1		515R37100	PIPE FROM TERM. VALVE TO EVAP.	TUBO DA VAL. TERM. A EVAP.	
2		515R34500	PIPE FROM TERM VALVE TO S. VALVE	TUBO DA VAL. TER.A VALVOLA SOLE.	
3		515R20000	INLET PIPE FROM SOLENOID VALVE	TUBO INGRESSO VALVOLA SOLEN.	
4	090229	525719000	MECCANICAL FLTER	FILTRO MECCANICO A RETINA	
5	087694	646735000	BODY SOLENOID VALVE	CORPO VALV.SOLENOIDE	
<b>5a</b>	<b>085847</b>	<b>0646729100</b>	<b>COIL WITHOUT CONNECTION</b>	<b>BOBINA PER VALVOLA SOLENOIDE</b>	<b>Up to 2020/26</b>
<b>5a</b>	<b>095063</b>	<b>0646R14000</b>	<b>COIL WITHOUT CONNECTION</b>	<b>BOBINA PER VALVOLA SOLENOIDE</b>	<b>From 2020/27</b>
6	087333	646740901	EXPANSION VALVE GAS R134A	VALVOLA TERM. GAS R134A	R134a
6	095674	646R16000	EXPANSION VALVE GAS R448A	VALVOLA TERM. GAS R448A	R448A,R449A,R407C,R407A
6	088501	646751900	EXPANSION VALVE GAS R404a	VALVOLA TERM. GAS R404a	R404A,R452A,R407F,R422A
*	089614	565717600	INSULATION EXPANSION VALVE	ISOLANTE X VALVOLA TERMOST.	
7	0C3523	639803900	STRIP	FASCETTA STRINGICAVO	
8	095458	544R07300	DISCHARGE PIPE	SIFONE SCARICO ACQUA SX	
9		549727400	PROTECTION ELECTRICAL BOX	SCATOLA PROT. IMPIANTO ELETTRI.	
10	092175	646R06900	NTC PROBE 6X20 BLU 'CELL'	SONDA CELLA	
<b>11</b>	<b>096125</b>	<b>0646R07701</b>	<b>NTC PROBE 6X40 VERDE</b>	<b>SONDA EVAPORATORE</b>	
12	093599	639R10000	CLAMP	MORSETTIERA	
<b>13</b>	<b>093037</b>	<b>682721102</b>	<b>CELL FAN</b>	<b>VENTILATORE CELLA</b>	
14		546R39202	FAN SUPPORT	SUPPORTO VENTILATORE	
15		546R39101	FAN COVER	PROTEZIONE VENTILATORE	
16	0A8719	541706000	FAN RUBBER	GOMMINI PER VENT	
17	095621	617R23800	DISCHARGE WARM CABLE 35 w/m	CAVO RISCALDANTE SCARICO	a
17	095620	617R23700	DISCHARGE WARM CABLE	CAVO RISCALDANTE SCARICO	b
17	095619	617R23600	DISCHARGE WARM CABLE	CAVO RISCALDANTE SCARICO	c
18	095624	617R24100	DEFROST WARM CABLE 25 w/m	CAVO RISCALDANTE SCHIENALE	a
18	095623	617R24000	DEFROST WARM CABLE	CAVO RISCALDANTE SCHIENALE	b
18	095622	617R23900	DEFROST WARM CABLE	CAVO RISCALDANTE SCHIENALE	c
19	0A9671	648718900	ELTH THERMOSTAT	TERMOSTATO ELTH +40/+30	
20		515R37200	OUT PIPE EVAPORATOR	EVAPORATOR FLOW BACK PIPE	
21	083814	617R03800	PTC	CARTUCCIA AUTOREGOLANTE PTC	
22	091356	512701800	EVAPORATOR WATER BASIN	BACINELLA DI EVAP	
23					
24					
25					
26					

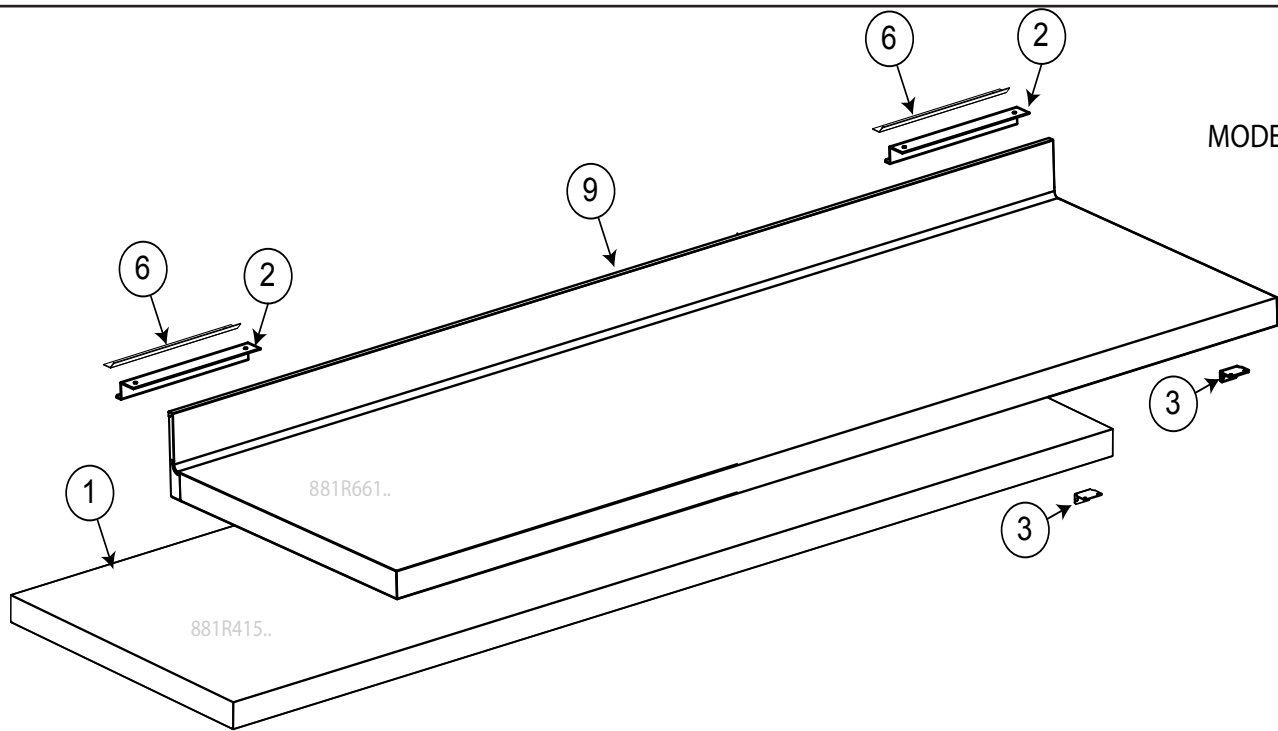

MODEL=H6FTN4R

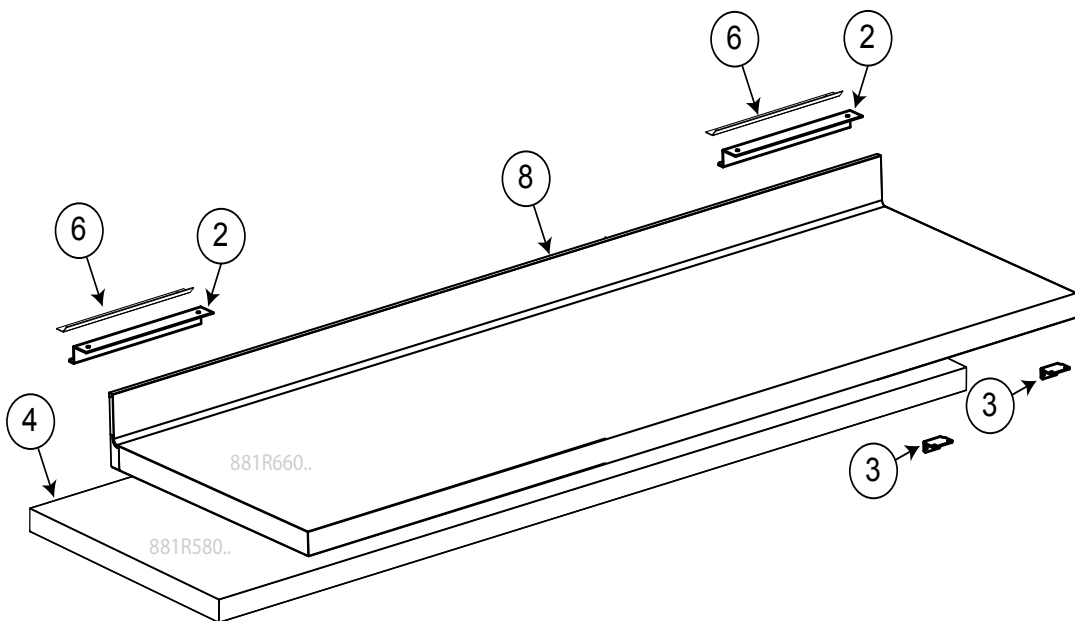

MODEL=H6FTN3R

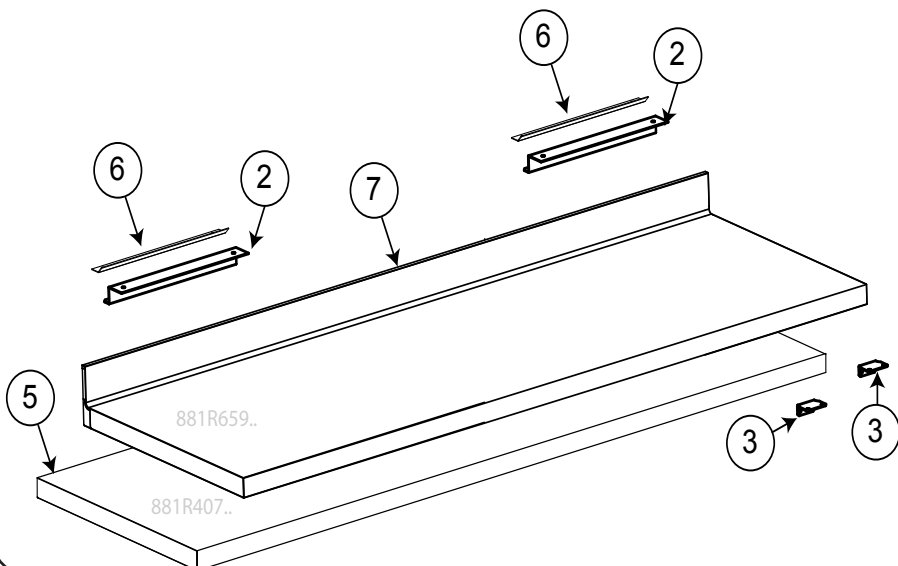

MODEL=H6FTN2R



Pos	Code	Factory code	Description	Descrizione	Ref/notes
reference pag.7					
			Worktop		Top
1		835R65901	WORKTOP MODULE 4C H50 "R-L"	TOP 4 VANI H 50 DX-SX	c (without S.back)
2		501775700	HOOK FOR TOP	GANCIO PER RIPIANO	
3	095330	505R25301	BRACKET SHELF	STAFFA PER RIPIANO	
4		835R65401	WORKTOP MODULE 3C H50 "R-L"	TOP 3 VANI H 50 DX-SX	b (without S.back)
5		835R65701	WORKTOP MODULE 2C H50 "R-L"	TOP 2 VANI H 50 DX-SX	a (without S.back)
6	093186	505751500	HOOK FOR TOP ON THE COUNTER	FISSAGGIO RIPIANO AL TAVOLO	
7		835R65801	WORKTOP ASS. WITH S.BACK 2C "R-L"	TOP CON ALZATINA 2 VANI DX-SX	a (whit S.back)
8		835R65601	WORKTOP ASSEMBLY 3C S/BACK "R-L"	TOP CON ALZATINA 3 VANI DX-SX	b (whit S.back)
9		835R66001	WORKTOP ASS. WITH S.BACK 4C "R-L"	TOP CON ALZATINA 4 VANI DX-SX	c (whit S.back)
10					
11					
12					
13					
14					
15					
16					
17					
18					
19					
20					
21					
22					
23					
24					

**CL APX H650  
DOOR**

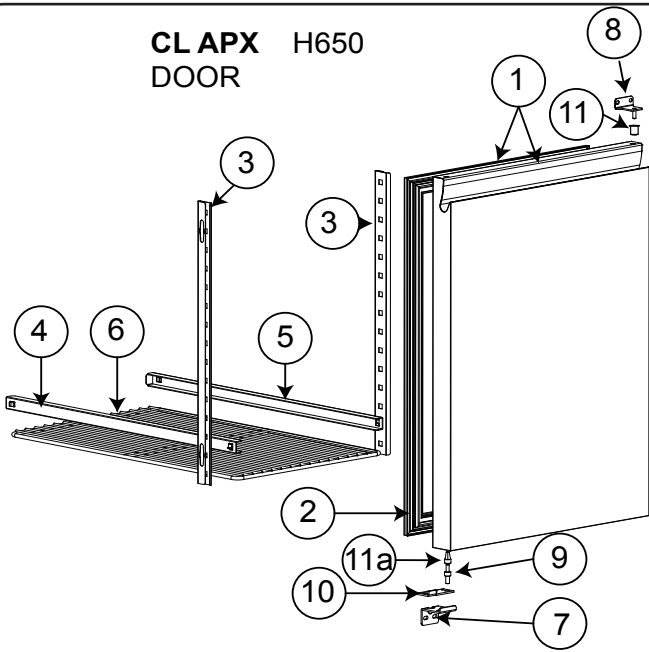

**CL APX H650  
DRAW.1/2**

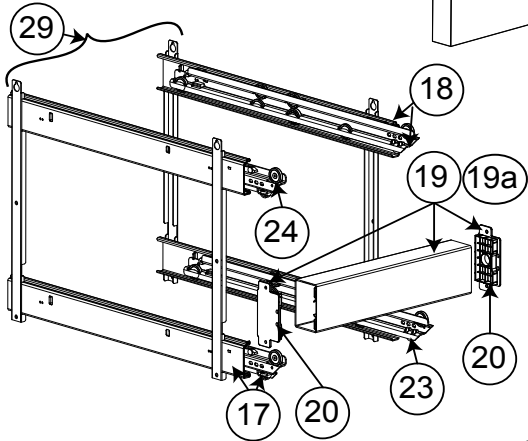
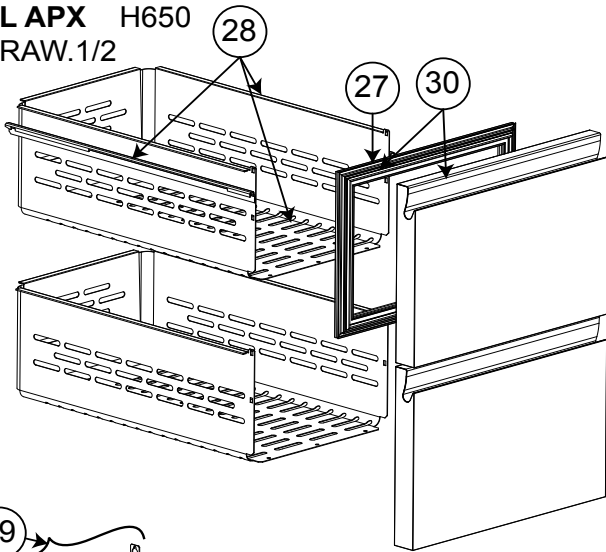

**CL APX H650  
BOTTLE DRAW.**

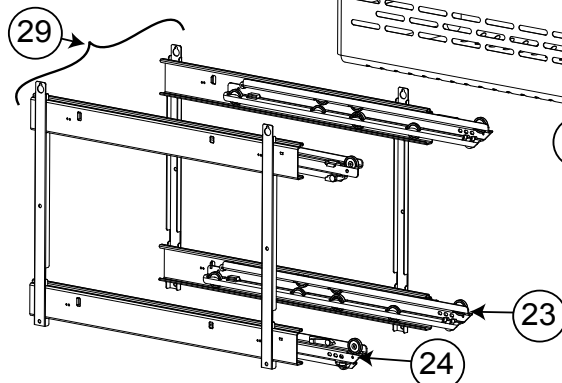

**CL APX H650  
DRAW 1/3**

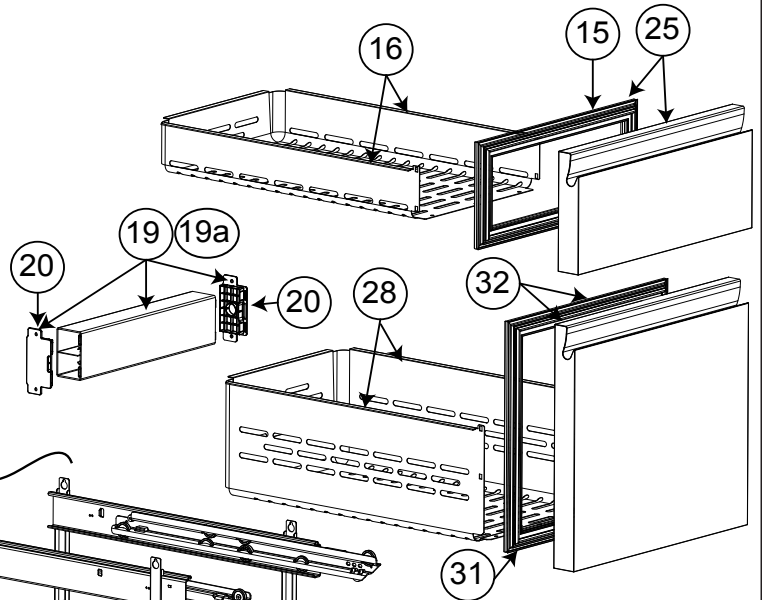
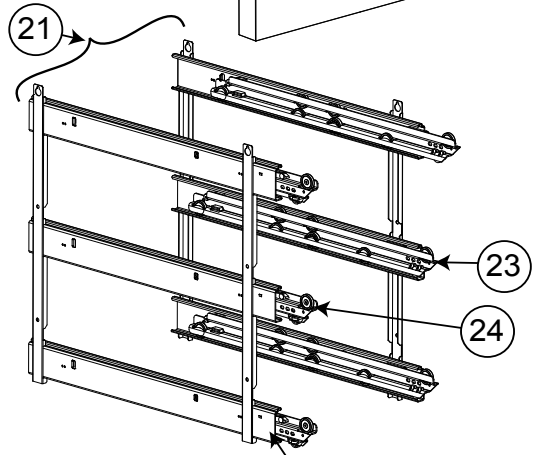
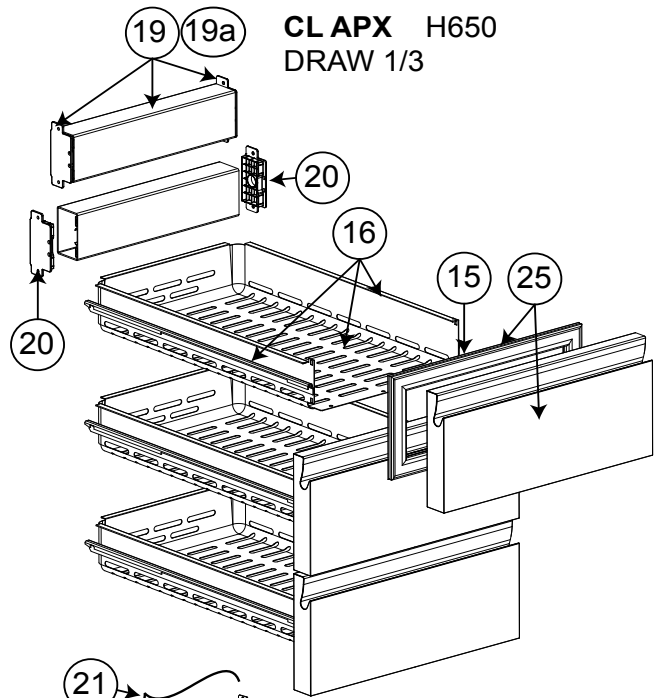

**BL H650  
DOOR**

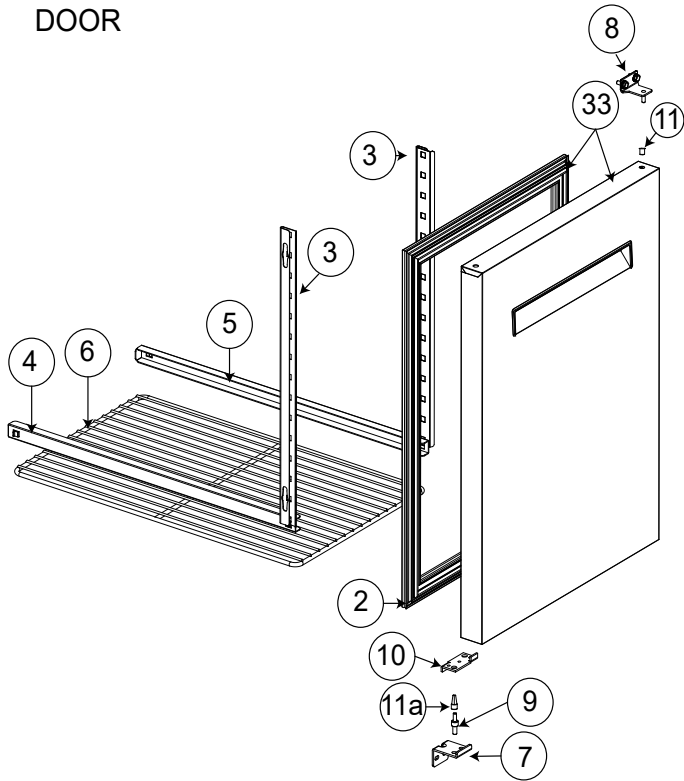

**BLH650  
DRAW.1/3**

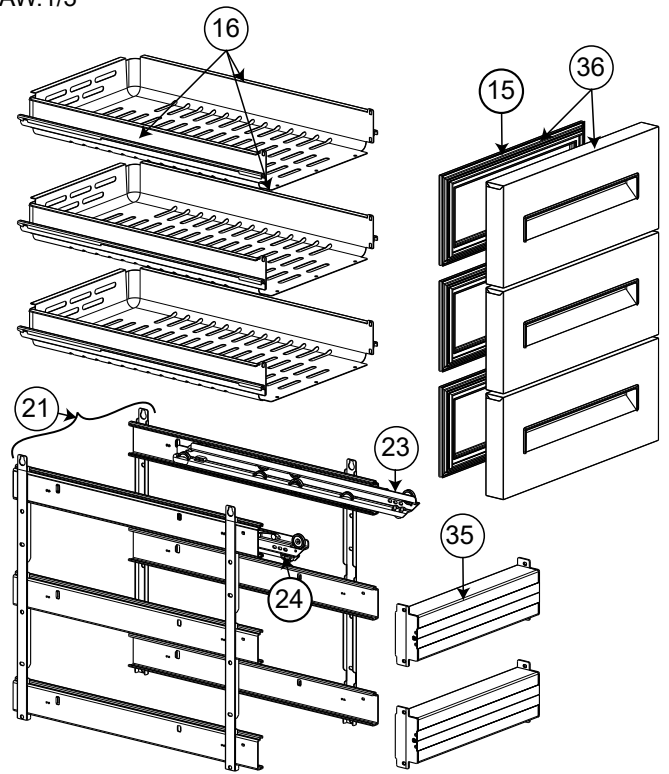

**BLH650  
DRAW.1/2**

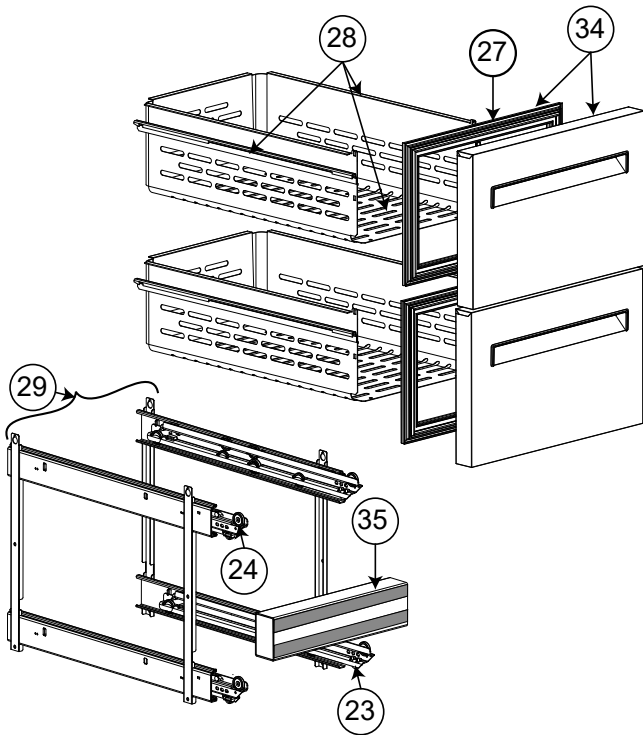

**BL H650  
DRAW.Bottle**

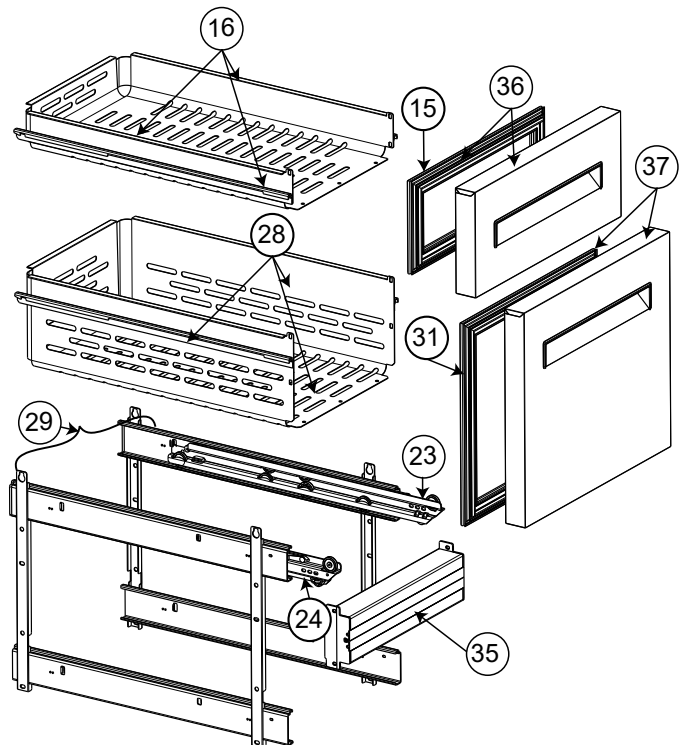

Pos	Code	Factory code	Description	Descrizione	Ref/notes
reference pag. 9_10					
<b>Doors and Drawers</b>			<b>Porta e Cassetti</b>		
1	095832	835R63802	FOAMED D. ASSEMBLY H700 apx/zan	PORTA SCHIU. CON GUARNI.APX_ZAN	CL Apx
2	095657	548R11400	MAGNETIC GASKET H650	GUARNIZIONE PORTA	
3	095227	503R09702	FRONT SUPPORT GRIDS H700	FRONTALE SUPPORTO GUIDE	
4	095228	502R84601	LEFT GUIDE FOR SHELF	GUIDA A "C" SX TAV NGC H700/H650	
5	095229	502R84701	RIGHT GUIDE FOR SHELF	GUIDA A "C" DX TAV NGC H700/H650	
6	095231	514R23500	SHELF	GRIGLIA RILSAN TAVOLO H650/H700	
7	095326	505R23702	LOWER HINGE H650/H700	CERNIERA INFERIORE	
8	095327	505R23803	UPPER HINGE H650/H700	CERNIERA SUPERIORE	
9	087667	514746701	PIN FOR DOOR	PERNO PER CERNIERA INFERIORE	
10	089146	800735200	DOOR OPENING END COURSE	PIASTRINA FERMO BATTUTA PORTA	
11	081807	549700000	UPPER DOOR BUSH	BOCCOLA X CERNIERA SUPERIORE	
11a	087955	549703000	LOWER DOOR BUSH	BOCCOLA X CERNIERA INFERIORE	
15	095654	548R13200	GASKET DRAWER 1/3	GUARNIZ.CASS.1/3	
16	096133	833R40801	1/3 DRAW+GUIDES (WITHOUT FRONTAL)	ASS.INVOLUCRO CASSETTO+GUIDE	
17	095266	832R23200	LEFT SUPPORT DRAWERS	CARRELLO SX PER MOD.CASSETTI	
18	095267	832R23300	RIGHT SUPPORT DRAWERS	CARRELLO DX PER MOD.CASSETTI	
19	095365	875R33501	CROSSBEAM ASSEMBLY - DRAWERS	TRAVERSA CASSETTO 1/ E 1/2 TN	CL only refrigerated - up to 2019/13 - Replaced by pos. 35
19a	095366	835R53802	FOAM PILLAR ASS. - DRAWERS	TRAVERSA CASSETTO 1/ E 1/2 BT	CL only freezer
20	095552	543R18901	PLASTIC PILLAR PLUG RIGHT/LEFT	TAPPO TRAVERSA DX E SX	CL only refrigerated
21	096134	833R41000	1/3 SUPPORT +GUIDE ASSEMBLY	SUPPORTO TELAIO DX E SX CASS.1/3	
23	095267	832R23300	RIGHT SLIDING GUIDE	GUIDA SCORREVOLE DX	
24	095266	832R23200	LEFT SLIDING GUIDE	GUIDA SCORREVOLE SX	
<b>25</b>	<b>097076</b>	<b>835R64002</b>	<b>FOAMED FRONT DRAW. 1/3 APX</b>	<b>ASS.CASS.1/3 SCHIUMATO</b>	<b>CL</b>
27	095655	548R13100	GASKET DRAWER 1/2	GUARNIZ.CASS.1/2 TAV NGC H700	
28	095873	833R40700	1/2 DRAW+GUIDES	INVOLUCRO CON GUIDE	
29	096136	833R40900	1/2 SUPPORT +GUIDE ASSEMBLY	SUPP. TELAIO DX E SX CASS.1/2-2/3	
30	095833	835R63902	FOAMED FRONT DRAW. 1/2 APX	ASS.CASS.1/2 SCHIUM. APX	CL
31	095656	548R13700	GASKET DRAWER 2/3	GUARNIZ.CASS.2/3 TAV NGC H650	
32		835R67001	2/3 FOAMED DRAWER ASSEMBY H650	ASS.CASS.2/3 SCHIUM. APX	CL
<b>33</b>	<b>096128</b>	<b>835R70401</b>	<b>FOAMED DOOR ASSEMBLY H650 BL</b>	<b>PORTA SCHIU. CON GUARNIIONE BL</b>	<b>BL</b>
<b>34</b>	<b>096131</b>	<b>835R70501</b>	<b>1/2 FO. DRAWER ASSEMBLY BL H650</b>	<b>ASS.CASS.1/2 SCHIUMATO</b>	<b>BL</b>
<b>35</b>	<b>096130</b>	<b>835R70800</b>	<b>CROSSBEAM ASSEMBLY - DRAWERS</b>	<b>TRAVERSA CASSETTO TN</b>	<b>BL</b>
<b>36</b>	<b>096132</b>	<b>835R70601</b>	<b>1/3 FO. DRAWER ASSEMBLY BL H650</b>	<b>ASS.CASS.1/3 SCHIUMATO</b>	<b>BL</b>
<b>37</b>	<b>096135</b>	<b>835R70700</b>	<b>2/3 FO. DRAWER ASSEMBLY BL H650</b>	<b>ASS.CASS.2/3 SCHIUMATO</b>	<b>BL</b>
			BL= Benefit line		
			CL= Concept line		

\* = On demand

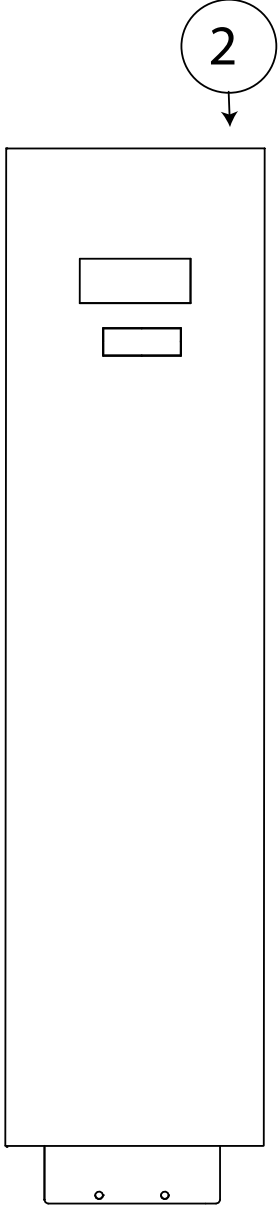
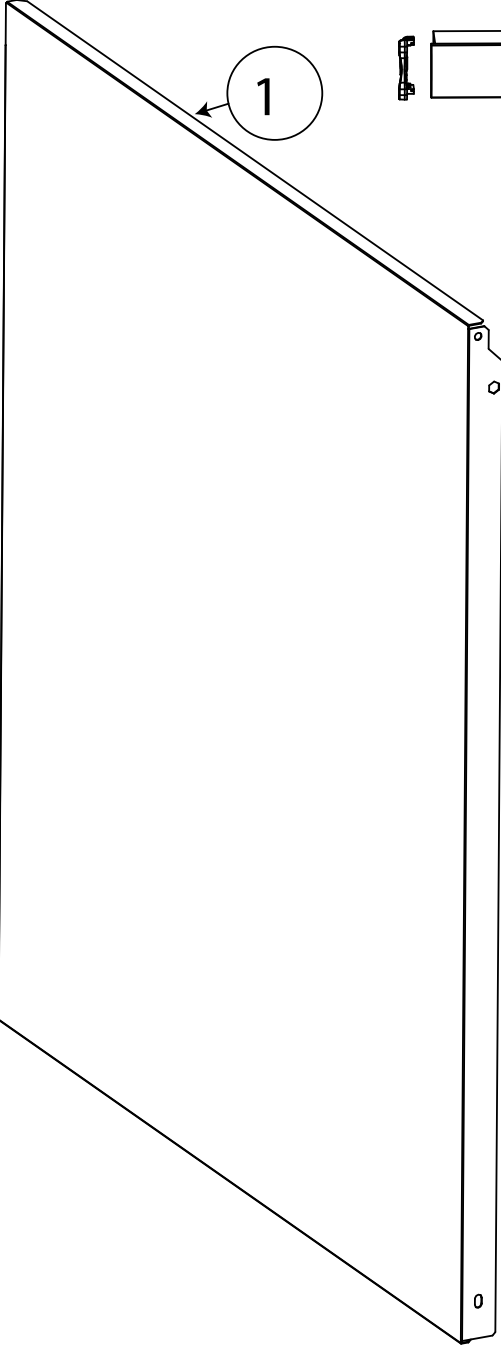
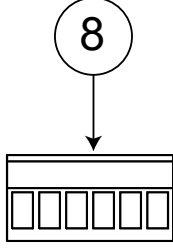
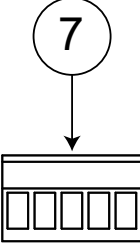
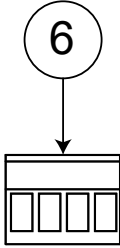
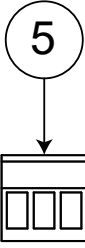
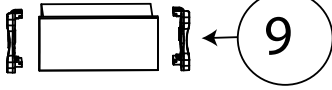
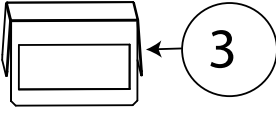

Pos	Code	Factory code	Description	Descrizione	Ref/notes
reference pag.12					
<b>Control panel</b>			<b>Pannello di controllo</b>		
1	096633	503R63800	EXTERNAL SIDE PANEL CL H650	PANNELLO ESTERNO	
2		509R23900	CTRL PANEL APX GLUED IR33 "L" rem	PANNELLO CONTROLLO APX rem	
3		503R49700	IR33 COVER COUNTERS C.L.	COPERTURA CONTROLLORE	
4	095616	755R14800	ADHESIVE DECOR C.L APX rem	MASCHERINA SERIGRAFATA APX rem	CL
5	088998	639722900	CONNECTOR MSTB 2.5/3 ST PASSO 5	CONETTORE PASS.5 MSTB 2.5/3 ST	
6	091682	639R04400	CONNECTOR MSTB 2.5/4 ST PASSO 5	CONETTORE PASS.5 MSTB 2.5/4 ST	
7		639725900	CONNECTOR MSTB 2.5/5 ST PASSO 5	CONETTORE PASS.5 MSTB 2.5/5 ST	
8	095244	639723400	CONNECTOR MSTB 2.5/6 ST PASSO 5	CONETTORE PASS.5 MSTB 2.5/6 ST	
9	093434	646R11101	TERMOREGOLAT. IR33 IMEL1J0559	CONTROLLORE IR33	4 relays - Up to 2023/16 order KIT 097750, see TB VTX2023_08
9	097579	855R18401	TERMOREGOLAT. IJF SMALL	CONTROLLORE IJF SMALL	From 2023/17
12		598R42202	ADHESIVE DECOR ELUX	MARCHIO ADESIVO ELECTROLUX	BL
13		598R42303	STICKER ALPENINOX BL	MARCHIO ADESIVO ALPENINOX	BL
14		598R42101	STICKER ZANUSSI BL	MARCHIO ADESIVO ZANUSSI	BL
15					
16					
17					
18					
19					
20					
21					
22					
23					
24					

**Finanzen / Service**  
**28307 Bremen**  
Thalendorststraße 15  
Tel.+49 421 48557-0  
Fax+49 421 488650  
bremen@nordcap.de

**Vertrieb Ost**  
**12681 Berlin**  
Wolfener Straße 32/34, Haus K  
Tel.+49 30 936684-0  
Fax+49 30 936684-44  
berlin@nordcap.de

**Vertrieb West**  
**40699 Erkrath**  
Max-Planck-Straße 30  
Tel.+49 211 540054-0  
Fax+49 211 540054-54  
erkrath@nordcap.de

**Vertrieb Nord**  
**21079 Hamburg**  
Großmoorbogen 5  
Tel.+49 40 766183-0  
Fax+49 40 770799  
hamburg@nordcap.de

**Vertrieb Süd**  
**55218 Ingelheim**  
Hermann-Bopp-Straße 4  
Tel.+49 6132 7101-0  
Fax+49 6132 7101-20  
ingelheim@nordcap.de



[www.nordcap.de](http://www.nordcap.de)