

# Ersatzteilliste-Explosionszeichnung COOL-LINE Panorama-Kühlvitrine Serie KRISTALL

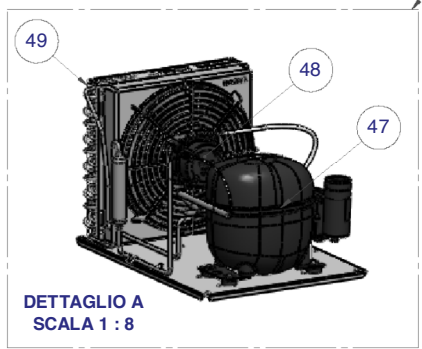

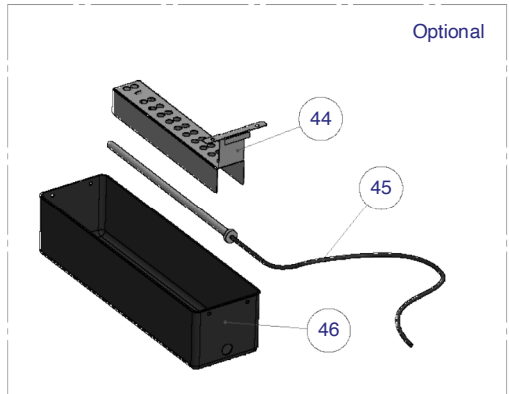
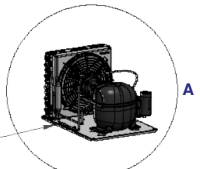
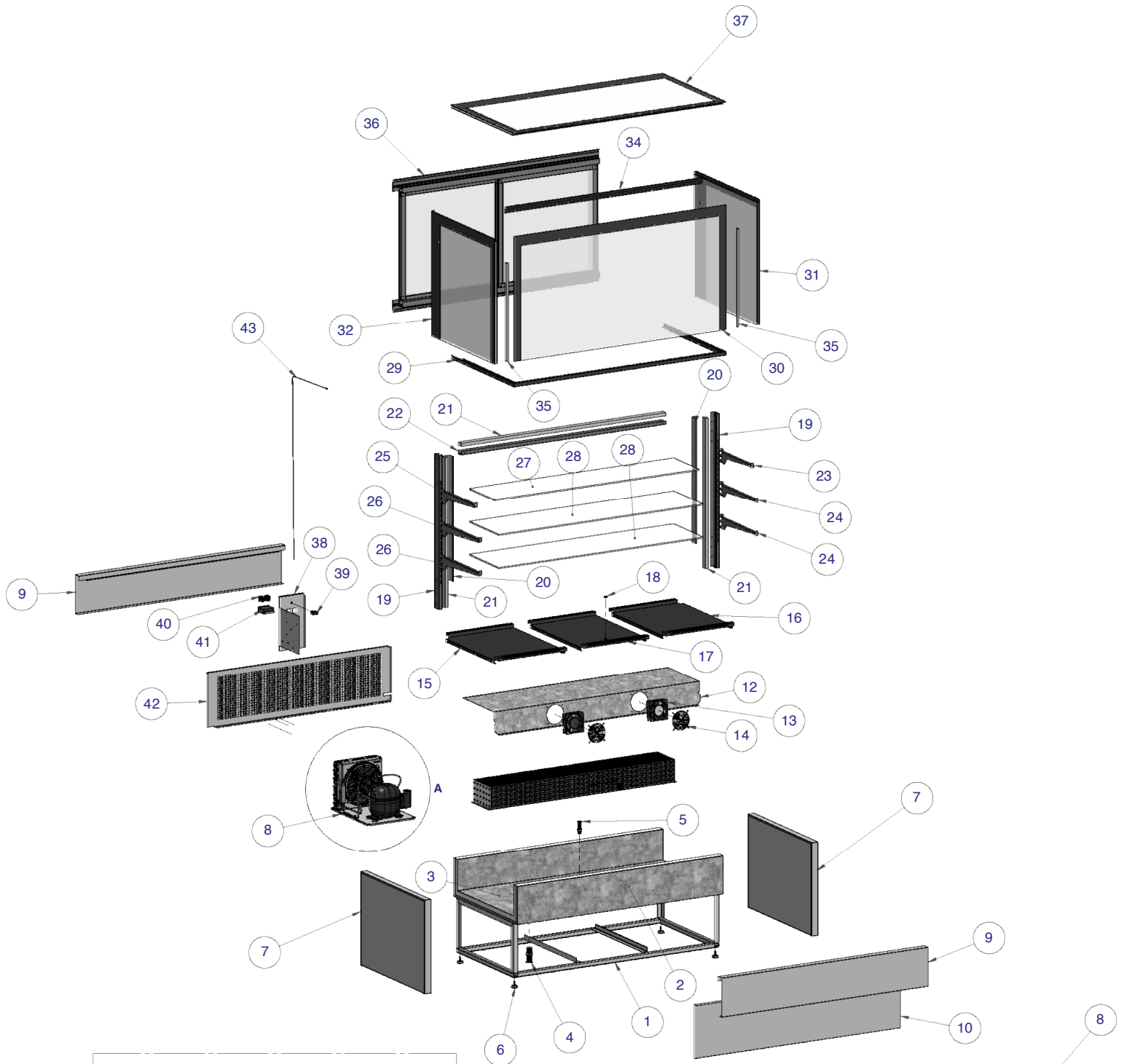

# KRISTALL

Nr.	Descrizione - Description
1	TELAIO KRISTALL 150
2	LAMIERA ESTERNA VASCA KRISTALL 150
3	LAMIERA INTERNA VASCA KRISTALL 150
4	TUBO SCARICO D. 32X90
5	TUBO SCARICO D. 20X75
6	PIEDINO REGOLABILE POLIT. NERO
7	ASSIEME FIANCATA KRISTALL 2020 F21PVA
8	UNITA' R290 NLE8,8CN RV101999-2 BANCHI
9	DEC SUP KRISTALL 150 GRIGIO
10	DEC INF KRISTALL 150 GRIGIA
11	EVAP. R290 JINNY VENTILATO 150
12	PORTAVENTILATORE KRISTALL 150
13	VENTILATORE 119X119X38 A FILO 3 MT MASSA
14	GRIGLIA DI PROTEZIONE 119X119
15	PIANO KRISTALL 150 SENZA FORO SX RAL 9005
16	PIANO KRISTALL 150 SENZA FORO DX RAL 9005
17	PIANO KRISTALL 150 CON FORO RAL 9005 OPACO
18	ANELLO PVC PER PIANO ESPOSIZIONE
19	CREMAGLIERA KRISTALL ZOIN
20	COPERTURA CREMAGLIERA KRISTALL
21	LISTELLI 20x38x1200
22	OMEGA KRISTALL 2020 150
23	MENSOLA 353 LUX DX KRISTALL
24	MENSOLA 403 LUX DX KRISTALL
25	MENSOLA 353 LUX SX KRISTALL
26	MENSOLA 403 LUX SX KRISTALL
27	CRISTALLO 08 KRISTALL 150 MENSOLA 30
28	CRISTALLO 08 KRISTALL 150 MENSOLA 35
29	CANALINO POST FIANCATA KRISTALL 150
30	CRISTALLO 20 KRISTAL 1460X775 FRONTALE

# KRISTALL

31	CRISTALLO 20 KRISTAL 751X775 LATERALE DX
32	CRISTALLO 20 KRISTAL 751X775 LATERALE SX
33	ANGOLARE INCASTRO V. FRONT. KRISTALL 150
34	ANGOLARE BATTUTA V. CAPP. KRISTALL 150
35	PLAFONIERA LED SL90 DX/SX 4K SAT L=608
36	KIT SCORREVOLE ROLLER KRISTALL 150
37	CRISTALLO 20 KRISTAL 1460X755 CAPPELLO
38	LAMIERA QUADRO ELETTRICO KRISTALL GRIGIO
39	INTER. TERMICO MICRODISGIUNTORE+PROTEZ.
40	INTERRUTTORE BIPOLARE
41	TERMOSTATO EVCO EV3X21N7VXR10
42	LAMIERA COP POST KRISTALL 150 GRIGIO
43	SONDA NTC TERM. 1,5M
44	PROTEZIONE PTC PER ZOIN
45	RESISTENZA PTC 270W+SPINA SCHUKO L=3000
46	VASCHETTA RACCOGLI CONDENSA 370X105G90
47	COMPRESSORE NEU6210U-A-CSIR R290
48	MOTOVENT UN R290 10/40W DA 4,8 A 11 SECO
49	CONDENS. FILOPACCO UNITÀ R290 6181-6210

**Finanzen / Service**  
**28307 Bremen**  
Thalenhorststraße 15  
Tel.+49 421 48557-0  
Fax+49 421 488650  
bremen@nordcap.de

**Vertrieb Ost**  
**12681 Berlin**  
Wolfener Straße 32/34, Haus K  
Tel.+49 30 936684-0  
Fax+49 30 936684-44  
berlin@nordcap.de

**Vertrieb West**  
**40699 Erkrath**  
Max-Planck-Straße 30  
Tel.+49 211 540054-0  
Fax+49 211 540054-54  
erkrath@nordcap.de

**Vertrieb Nord**  
**21079 Hamburg**  
Großmoorbogen 5  
Tel.+49 40 766183-0  
Fax+49 40 770799  
hamburg@nordcap.de

**Vertrieb Süd**  
**55218 Ingelheim**  
Hermann-Bopp-Straße 4  
Tel.+49 6132 7101-0  
Fax+49 6132 7101-20  
ingelheim@nordcap.de



[www.nordcap.de](http://www.nordcap.de)