

Ersatzteilliste-Explosionszeichnung

Elektro-Fritteuse EF9 / 1VB-23L-U1S-P-LS-AC

[Art. 406392345]



SPARE PARTS CATALOGUE
 CATALOGO PARTI DI RICAMBIO
 FRIGGITRICI ELETTRICHE ELETTRONICHE 23L E900XP
 ELECTRIC ELECTRONIC FRYERS 23L E900XP

PNC	VOLTAGE	DESCRIPTION	BRAND	REF
391339	380-415 3+N	23LT EL. FRYER PROGRAMMABLE	ELX	A
391340	380-415 3+N	23LT EL. FRYER-PROGR.+ PUMP	ELX	B
391341	400-430V 3+N	23LT EL. FRYER-PROG.+PUMP+LIFT	ELX	C
391345	400-430V 3+N	23L EL. FRYER-PROG.+PUMP+LIFT.+AUTO	ELX	D
391386	415-430 3+N	23LT EL. FRYER PROGRAMMABLE-430V	ELX	E
391387	415-430 3+N	23LT EL. FRYER-PROGR.+ PUMP-430V	ELX	F
391388	380-415 3+N	23LT EL. FRYER-PROG.+ PUMP+LIFT.	ELX	G
391390	400-430V 3+N	23L EL. FRYER-PROG.+PUMP+LIFT.+AUTO COOK-430V	ELX	H
392339	380-415 3+N	23LT EL. FRYER PROGRAMMABLE	ZAN	I
392340	380-415 3+N	23LT EL. FRYER-PROGR.+ PUMP	ZAN	J
392341	380-415 3+N	23LT EL. FRYER-PROG. + PUMP+LIFT.	ZAN	K
392345	400-430V 3+N	23L EL. FRYER-PROG.+PUMP+LIFT.+AUTO	ZAN	L
392386	415-430 3+N	23LT EL. FRYER PROGRAMMABLE-430V	ZAN	M
392387	415-430 3+N	23LT EL. FRYER-PROGR.+ PUMP-430V	ZAN	N
392388	415-430 3+N	23LT EL. FRYER-PROG.+ PUMP+LIFT.-430V	ZAN	O
392390	400-430V 3+N	23L EL. FRYER-PROG.+PUMP+LIFT.+AUTO COOK-430V	ZAN	P
393339	380-415 3+N	23LT EL. FRYER PROGRAMMABLE	OEM	Q
393340	380-415 3+N	23LT EL. FRYER-PROGR.+ PUMP	OEM	R
393341	380-415 3+N	23LT EL. FRYER-PROG.+ PUMP+LIFT.	OEM	S
393345	400-430V 3+N	23L EL. FRYER-PROG.+PUMP+LIFT.+AUTO	OEM	T
393386	415-430 3+N	23LT EL. FRYER PROGRAMMABLE-430V	OEM	U
393387	415-430 3+N	23LT EL. FRYER-PROGR.+ PUMP-430V	OEM	V
393388	415-430 3+N	23LT EL. FRYER-PROG.+ PUMP+LIFT.-430V	OEM	W
393390	400-430V 3+N	23L EL. FRYER-PROG.+PUMP+LIFT.+AUTO COOK-430V	OEM	X

Index

General componets / Componenti struttura	Page 2
Electric components / Componenti elettrici	Page 3
Well / Vasca	Page 4
Lifting & Pump components / Componenti	Page 5
Spare parts list / Liste ricambi	Page 6,7,8

Bold = Last change
Grassetto= Ultima modifica

Ed. page revision 2018 - 10

From Ser. Nr. 8041 Up to Ser. Nr.	Ed. document . N° 3 / 09-2019	Page 1	Doc. N° 59785VY00
--------------------------------------	-------------------------------	--------	--------------------------

FRIGGITRICI ELETTRICHE ELETTRONICHE 23L E900XP
 ELECTRIC ELECTRONIC FRYERS 23L E900XP

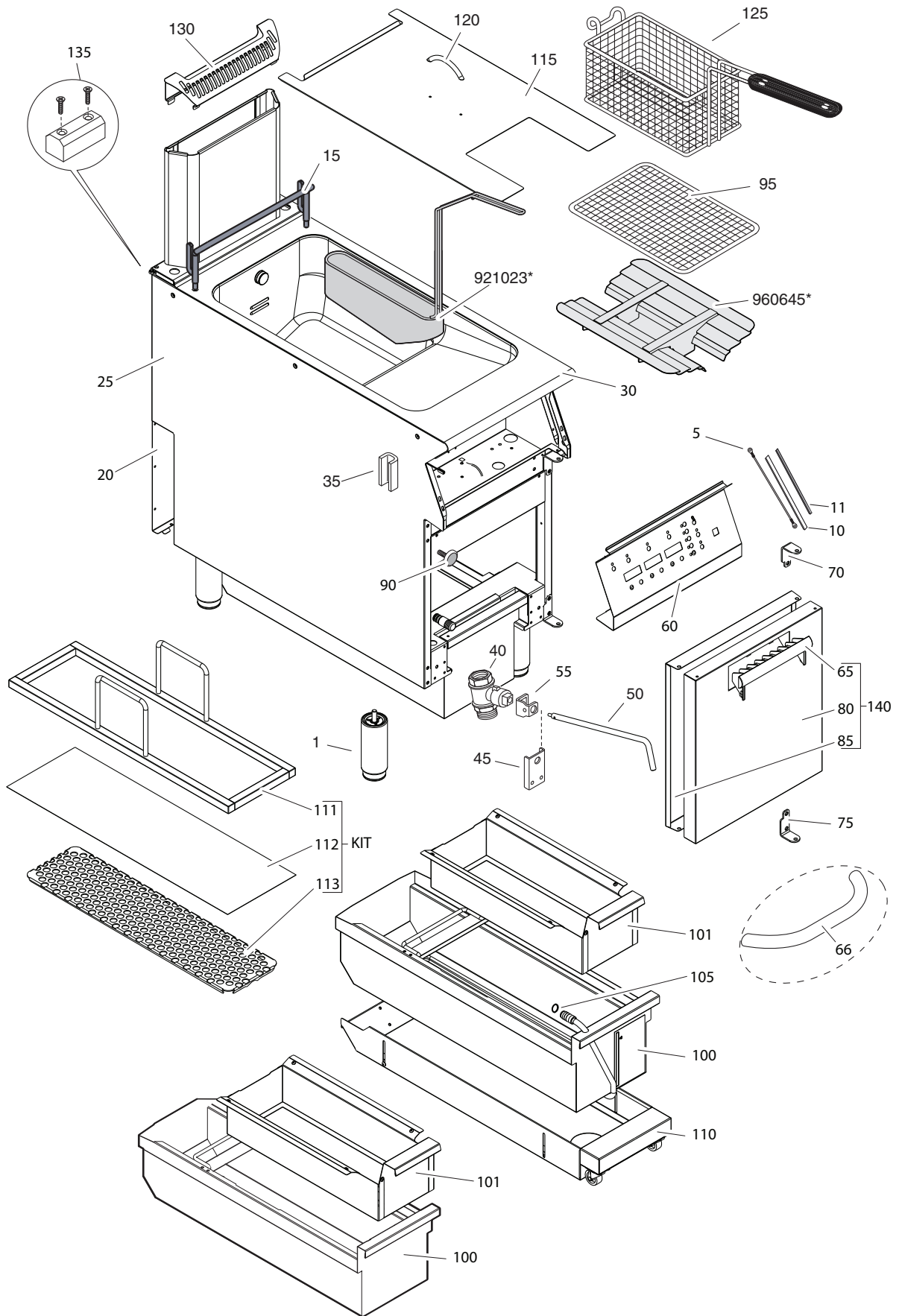

FRIGGITRICI ELETTRICHE ELETTRONICHE 23L E900XP
 ELECTRIC ELECTRONIC FRYERS 23L E900XP

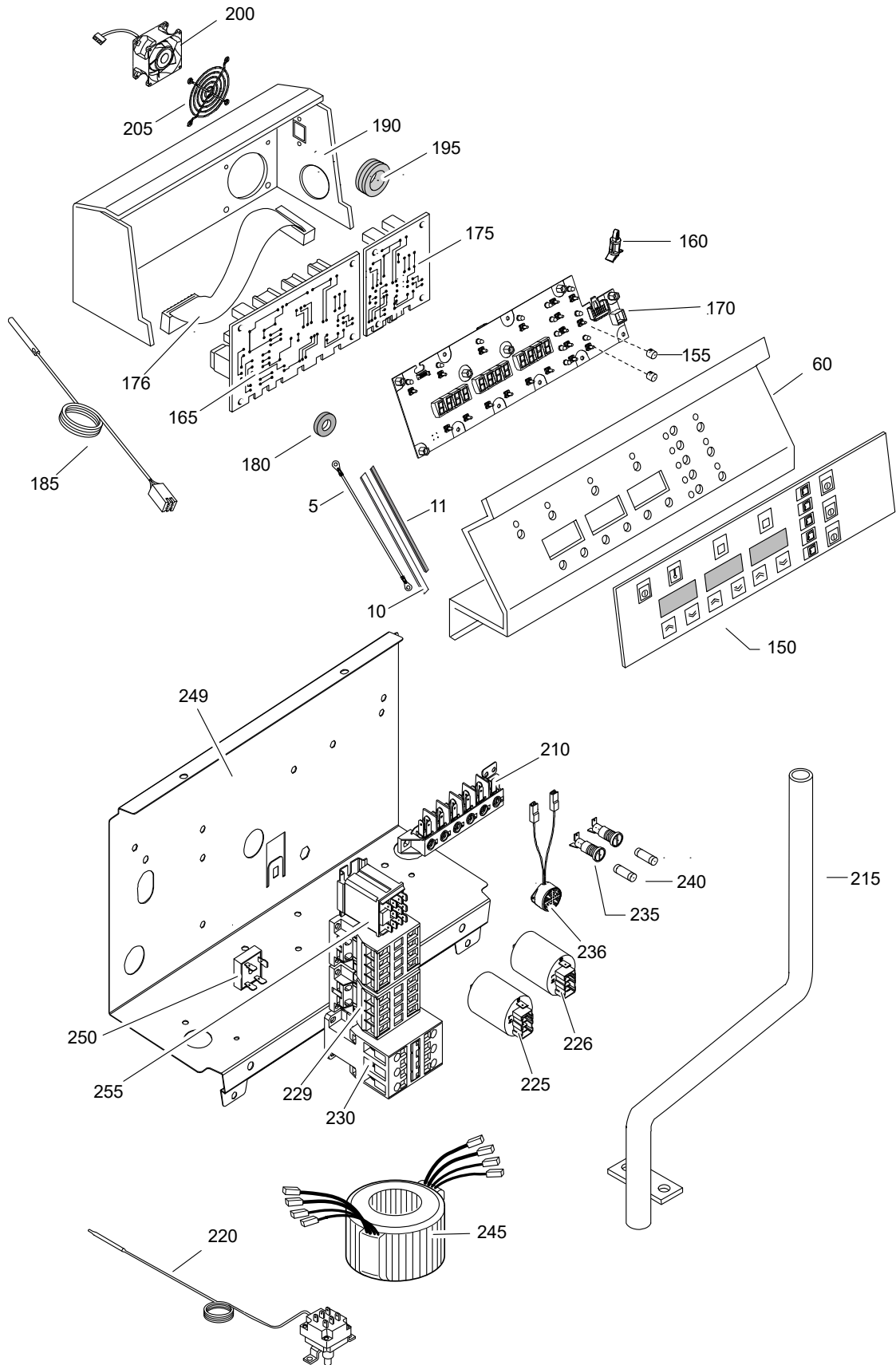

FRIGGITRICI ELETTRICHE ELETTRONICHE 23L E900XP
ELECTRIC ELECTRONIC FRYERS 23L E900XP

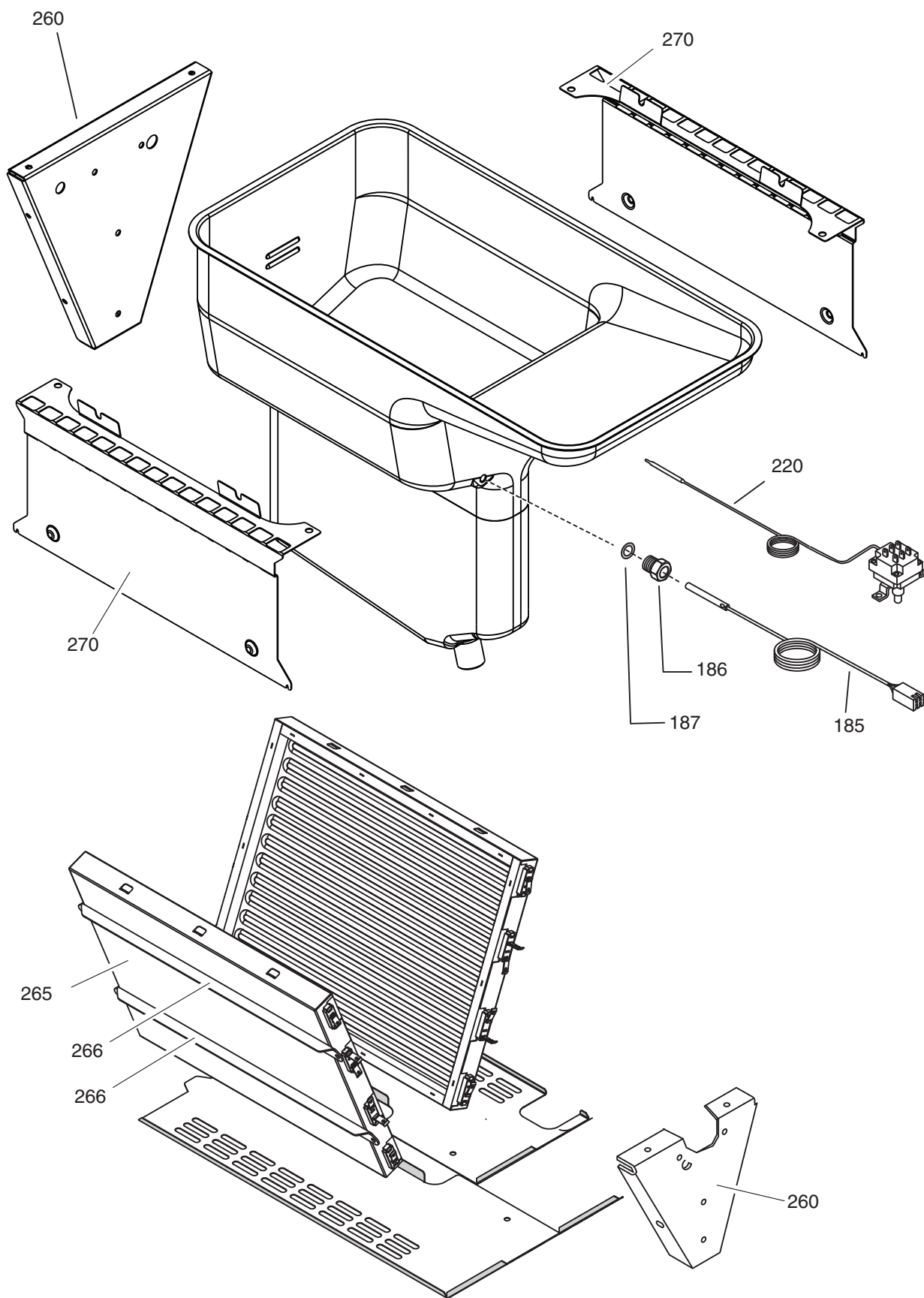

FRIGGITRICI ELETTRICHE ELETTRONICHE 23L E900XP
 ELECTRIC ELECTRONIC FRYERS 23L E900XP

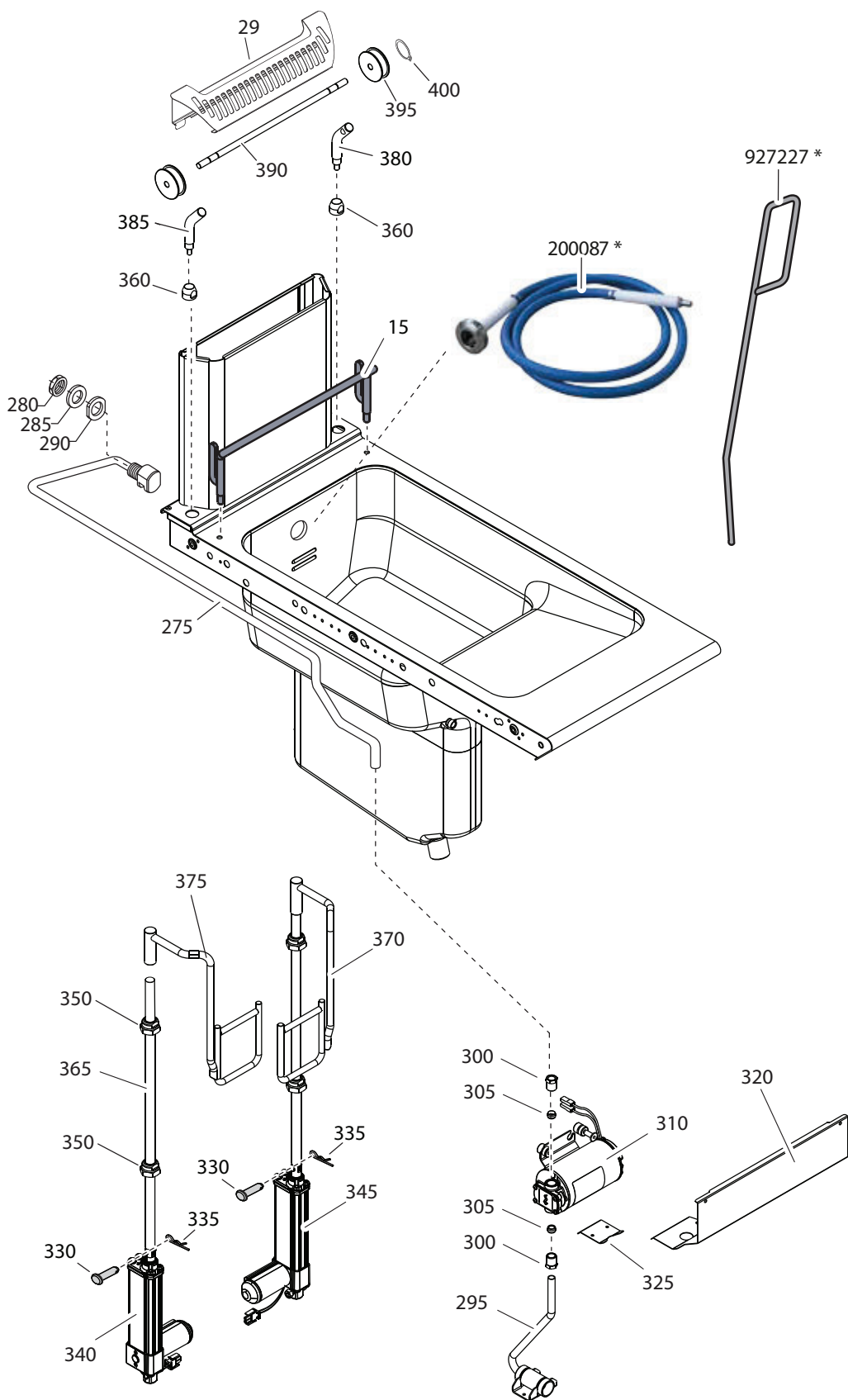

FRIGGITRICI GAS ELETTRONICHE 23L E900XP
ELECTRIC ELECTRONIC FRYERS 23L E900XP

Pos	Spare part Code	Factory Code	Descrizione	Description	Ref./Note
1	0C0204	835856901	PIEDE	FOOT	
5	0C7366	830825901	CAVETTO SOSTEGNO CRUSCOTTO	SUPPORT CABLE, CONTROL PANEL	
10	0C7307	543831700	GUARNIZIONE - BIANCO	WHITE GASKET	SILIC.5X10MM
11	0C2496	543821900	GUARNIZIONE - GRIGIA	GRAY GASKET	SPONGE 6X2MM
15	006583	516847804	SUPPORTO CESTELLO	BASKET SUPPORT	A, B, E, F, I, J, M, N, Q, R, U, V
20	0CB367	5038AGG01	SCHIENALE	BACK PANEL	C,D,G,H,K,L,O,P,S,T,W,X
			SCHIENALE	BACK PANEL	A,B,E,F,I,J,M,N,Q,R,U,V
25	*	85089JC00	ASS. FIANCO DX	RIGHT PANEL	A, B, C, D, E, F, G, H
	0C8181	85089JD00	ASS. FIANCO SX	LEFT PANEL	A, B, C, D, E, F, G, H
	0CB368	85089JF00	ASS. FIANCO DX	RIGHT PANEL	I, J, K, L, M, N, O, P, Q, R, S, T, U, V, W, X
	0CB369	85089JG00	ASS. FIANCO SX	LEFT PANEL	I, J, K, L, M, N, O, P, Q, R, S, T, U, V, W, X
30	0CB370	87089RT02	ASS.VASCA FRIGG.23L	COMPLETE WELL FRYER 23L	B, F
	0CB371	87089RU01	ASS.VASCA FRIGG.23L	COMPLETE WELL FRYER 23L	C, D, G, H
	0CB372	87089RW00	ASS.VASCA FRIGG.23L	COMPLETE WELL FRYER 23L	A, E
	0CB373	87089RX00	ASS.VASCA FRIGG.23L	COMPLETE WELL FRYER 23L	K, L, O, P, S, T, W, X
	0CB374	87089RY00	ASS.VASCA FRIGG.23L	COMPLETE WELL FRYER 23L	J, N, R, V
	0CB375	87089RZ00	ASS.VASCA FRIGG.23L	COMPLETE WELL FRYER 23L	I, M, Q, U
35	0C0156	527850500	PIASTRA FISSAGGIO FIANCHI	SIDE PANEL JOINTING PLATE	
40	006688	835855000	VALVOLA SCARICO	DRAIN VALVE	
45	*	50589K700	SUPPORTO LEVA SCARICO	SUPPORT, DRAIN EXTENSION	
50	0C0608	516868800	PROLUNGA LEVA SCARICO	DRAIN EXTENSION HANDLE	
55	006877	508897004	CONNESSIONE PROLUNGA SCARICO	CONNECTION, DRAIN EXTENSION	
60	0C7220	87089CU03	CRUSCOTTO MARCHIATO (no adesivo)	CONTROL PANEL BRANDED	WITHOUT STICKER: A, B, C, D, E, F, G, H
	0C7631	87089M902	CRUSCOTTO MARCHIATO (no adesivo)	CONTROL PANEL BRANDED	WITHOUT STICKER: I, J, K, L, M, N, O, P
	0C7635	87089MG03	CRUSCOTTO MARCHIATO (no adesivo)	CONTROL PANEL BRANDED	WITHOUT STICKER: Q, R, S, T, U, V, W, X
65	0C8769	54887AH00	MANIGLIA PORTA	DOOR HANDLE	ELUX: A, B, C, D, E, F, G, H
66	0C8190	54887A802	MANIGLIA PORTA	DOOR HANDLE	ZAN: I, J, K, L, M, N, O, P
	0A5021	854864203	MANIGLIA PORTA	DOOR HANDLE	OEM: Q, R, S, T, U, V, W, X
70	0C0139	516860901	CERNIERA SUPERIORE	HINGE, UPPER	
75	0C0138	516860801	CERNIERA INFERIORE	HINGE, LOWER	
80	0C7157	50389G300	PANNELLO PORTA DESTRA	RIGHT DOOR PANEL	A, B, C, D, E, F, G, H, I, J, K, L, M, N, O, P
80	*	50389MB01	PANNELLO PORTA DESTRA	RIGHT DOOR PANEL	Q, R, S, T, U, V, W, X
85	0C7158	50489CQ00	PANNELLO CONTROPORTA	INNER DOOR PANEL	
90	0C0201	830898201	MAGNETE PER PORTA	MAGNET, DOOR	
95	006130	830884701	GRIGLIA DI FONDO	WELL GRID	
100	0CB341	87589G400	BACINELLA OLIO (CON POMPA)	BASIN FOR OIL (WITH PUMP)	B, C, D, F, G, H, I, J, K, L, N, O, P, R, T, U, V, W, X
	0CB342	87589FL01	BACINELLA OLIO (SENZA POMPA)	BASIN FOR OIL (WITHOUT PUMP)	A, E, I, M, Q, U
101	0CB343	85589HC02	FILTRO OLIO (CASSETTINO)	OIL FILTER (SMALL TRAY)	
105	0C2183	543826400	OR (INNESTO PER POMPA)	O-RING (PUMP JOINT)	3PCS NEEDED B, C, D, F, G, H, I, J, K, L, N, O, P, R, T, U, V, W, X

FRIGGITRICI GAS ELETTRONICHE 23L E900XP
GAS ELECTRONIC FRYERS 23L E900XP

110	OCB344	87589F202	ASSIEME CARRELLO BACINELLA	COMPLETE BASIN TROLLEY	111+113 = KIT 200084 KIT 200085 (ONLY PAPER, 10PCS IN KIT) 111+113 = KIT 200084 C, D, G, H, K, L, O, P, S, T, W, X A, B, E, F, I, J, M, N, Q, R, U, V	
111	OCB346	51489FL01	PRESSORE	FILTER WEIGHT		
112	*	1428000	FILTRO CARTA	PAPER FILTER		
113	OCB347	50489WY00	SUPPORTO FILTRO CARTA	SUPPORT, PAPER FILTER		
115	0C1014	529889901	COPERCHIO FRIGG.	LID		
115	0C0613	529890101	COPERCHIO FRIGG.	LID		
120	OC0614	511819000	MANIGLIA COPERCHIO	HANDLE, LID		
125	006133	850894500	CESTELLO	BASKET		
130	OC7161	50489JL00	GRIGLIA CAMINO	GRID, CHIMNEY		
135	OC0137	516860702	PIASTRA GIUNZIONE APPARECC.	JOINTING REAR PLATE		
140	OC7163	85589CT03	ASS.PORTINA +MANIGLIA	COMPLETE DOOR WITH HANDLE		A, B, C, D, E, F, G, H
	OC7165	85589CU05	ASS.PORTINA+MANIGLIA	COMPLETE DOOR WITH HANDLE		I, J, K, L, M, N, O, P
	OC7627	85589CV02	ASS.PORTINA+MANIGLIA	COMPLETE DOOR WITH HANDLE		Q, R, S, T, U, V, W, X
150	OCB348	54887BV01	MEMBRANA ADESIVA	USER BOARD STICKER		B, F
	OCB349	54887BW01	MEMBRANA ADESIVA	USER BOARD STICKER	C, G	
	OCB350	54887C001	MEMBRANA ADESIVA	USER BOARD STICKER	K, O	
	OCB351	54887C101	MEMBRANA ADESIVA	USER BOARD STICKER	J, N	
	OCB352	54887C201	MEMBRANA ADESIVA	USER BOARD STICKER	I, M	
	OCB353	54887C600	MEMBRANA ADESIVA	USER BOARD STICKER	Q, U	
	OCB354	54887C700	MEMBRANA ADESIVA	USER BOARD STICKER	R, V	
	OCB355	54887C800	MEMBRANA ADESIVA	USER BOARD STICKER	S, W	
155	002670	548836902	PROLUNGA PULSANTE	EXTENSION, SWITCH		
160	OC1812	516865600	DISTANZIALE TRA SCHEDE	SPACER BETWEEN BOARDS		
165	OCB345	675860V02	SCHEDE MADRE (PREC10)	MOTHER BOARD		
170	OC6364	675860400	SCHEDA INTERFACCIA	USER INTERFACE		
175	OC6380	675851703	SCHEDA ESPANSIONE RELE'	RELE' BOARD	C,D,G,H,K,L,O,P,S,T, W,X	
176	OC6382	699802800	CAVO COMUNICAZIONE SCHEDE	FLAT CABLE	C,D,G,H,K,L,O,P,S,T, W,X	
180	OC1813	546813800	RONDELLA SCHEDA	WASHER, BOARD	10PCS PER PNC	
185	006609	675837201	SONDA NTC	NTC PROBE		
186	059295	514874500	RACCORDO DADO	CONNECTION NUT		
187	059293	543815000	GUARNIZIONE OR SONDA OLIO	OR , OIL PROBE		
190	*	50489V901	PROTEZIONE SCHEDA	PROTECTION, MAIN BOARD		
195	050180	246520500	PASSACAVO DIA.23	CABLE LEAD DIA.23		
200	OC3967	624810200	VENTILATORE	MOTORVENTILATOR		
205	*	831840800	GRIGLIA METALLICA VENT.	GRID, MOTORVENTILATOR		
210	058613	A05714000	MORSETTIERA	TERMINAL BOARD		
215	*	806824600	PROTEZIONE CAVO ALIMENTAZIONE	CABLE PROTECTION PIPE	C, D, G, H, K, L, O, P, S, T, W, X	
220	OCB239	646817N00	TERMOSTATO DI SICUREZZA	SAFETY THERMOSTAT		
225	049303	694605400	FILTRO TRIFASE	FILTER		
226	OCB477	694400U00	FILTRO RFI MONOFASE	SINGLE FASE R.I.FILTER		
229	006879	648807400	CONTATTORE	CONTACTOR	18A	
230	007080	648807700	CONTATTORE	CONTACTOR	30A	
235	*	652400A00	PORTAFUSIBILE	FUSE CARRIER	5X20MM	
	*	652400B00	PORTAFUSIBILE	FUSE CARRIER	5X20MM	
236	OCB376	655800401	BUZZER 12V	BUZZER 12V		
240	OC1480	652803300	FUSIBILE 6,3A	6,3A FUSE		

FRIGGITRICI GAS ELETTRONICHE 23L E900XP
GAS ELECTRONIC FRYERS 23L E900XP

245	006159	624805601	TRASFORMATORE	TRANSFORMER	B, C, D, F, G, H, J, K, L, N, O, P, R, S, T, V, W, X
249 250	006147	50489VA00 675830800	SCATOLA IMPIANTO EL PONTE RADDRIZZATORE	EL BOX DIODE BRIDGE	B, C, D, F, G, H, J, K, L, N, O, P, R, S, T, V, W, X
255	006610	648806900	RELE' SOLLEVATORI	RELAY LIFTERS	B, C, D, F, G, H, J, K, L, N, O, P, R, S, T, V, W, X
260 265	* 006158	50489V000 617821806	PANNELLO FRONTALE "V" RESISTENZA 9Kw 400V	FRONTAL PANEL "V" HEATING ELEMENT 9kW 400V	A, B, C, D, I, J, K, L, Q, R, S, T
	0CB356	61783AK01	RESISTENZA 9kW 440V	HEATING ELEMENT 9kW 440V	E, F, G, H, M, N, O, P, U, V, W, X
266 270	* *	50589KR00 50489V100	SUPPORTO FASCIA, RESISTENZA SUPPORTO SUPERIORE RESISTENZE	STRAPPER H.ELEMENT UPPER SUPPORT, HEAT.ELEMENT	
275	0CB357	83089M601	CONDUTTURA ASPIRAZIONE OLIO	OIL SUCTION PIPE	B, C, D, F, G, H, J, K, L, N, O, P, R, S, T, V, W, X
280	0C1684	516849000	DADO	NUT	B, C, D, F, G, H, J, K, L, N, O, P, R, S, T, V, W, X
285	0C1686	508891200	RONDELLA	WASHER	B, C, D, F, G, H, J, K, L, N, O, P, R, S, T, V, W, X
290	0C3659	516865900	RONDELLA	WASHER	B, C, D, F, G, H, J, K, L, N, O, P, R, S, T, V, W, X
295	0CB358	80589DL00	CONDUTTURA CARICO OLIO	INLET PIPE, OIL	B, C, D, F, G, H, J, K, L, N, O, P, R, S, T, V, W, X
300	006964	514879601	RACCORDO	NIPPLE	B, C, D, F, G, H, J, K, L, N, O, P, R, S, T, V, W, X
305	0CB359	516874402	OGIVA	BICONICAL RING	B, C, D, F, G, H, J, K, L, N, O, P, R, S, T, V, W, X
310	006146	686800003	POMPA CARICO OLIO	PUMP, OIL CIRCULATION	B, C, D, F, G, H, J, K, L, N, O, P, R, S, T, V, W, X
320 325	* *	50489VB01 50589JY00	CHIUSURA POMPA PROTEZIONE CARICO	PANEL, PUMP TUBE PROTECTION	B, C, D, F, G, H, J, K, L, N, O, P, R, S, T, V, W, X
330	0CB363	219812K01	PERNO CON TESTA Ø 5,9	PIN Ø 5,9	C, D, G, H, K, L, O, P, S, T, W, X
335	0CB364	219812J00	COPIGLIA DI SICUREZZA 23mm	COTTER PIN 23mm	C, D, G, H, K, L, O, P, S, T, W, X
340	0CB242	611809G00	ATTUATORE PER SOLLEVAMENTO DX	RIGHT MOTOR ELEVATOR	C, D, G, H, K, L, O, P, S, T, W, X
345	0CB241	611809F00	ATTUATORE PER SOLLEVAMENTO SX	LEFT MOTOR ELEVATOR	C, D, G, H, K, L, O, P, S, T, W, X
350	0CB387	51489FC00	BOCCOLA PER SOLLEVATORI	BUSH, LIFT ROD	C, D, G, H, K, L, O, P, S, T, W, X
360	0C5086	518817300	BOCCOLA FISS.SUPPORTI	BUSH, LIFT ROD	C, D, G, H, K, L, O, P, S, T, W, X
365	0CB388	51489FB01	ASTA SOLLEVAMENTO	ROD, LIFT BASKET	C, D, G, H, K, L, O, P, S, T, W, X
370	0C7198	83089FF01	SUPPORTO DX CESTELLI	RIGHT SUPPORT BASKET	C, D, G, H, K, L, O, P, S, T, W, X
375	0C7199	83089FG01	SUPPORTO SX CESTELLI	LEFT SUPPORT BASKET	C, D, G, H, K, L, O, P, S, T, W, X
380	0CB365	51689AJ01	SUPPORTO DESTRO	RIGHT SUPPORT	C, D, G, H, K, L, O, P, S, T, W, X
385	0CB366	51689AH01	SUPPORTO SINISTRO	LEFT SUPPORT	C, D, G, H, K, L, O, P, S, T, W, X
390	0C1027	516866500	BARRA SUPPORTO CESTELLI	ROD, BASKET SUPPORT	C, D, G, H, K, L, O, P, S, T, W, X
395	0C1028	516849400	RUOTA GUIDA ASTA SOLL.	WHEEL, ROD LIFTER	C, D, G, H, K, L, O, P, S, T, W, X
400	067004	219001015	ANELLO SEEGER	SEEGER RING	C, D, G, H, K, L, O, P, S, T, W, X
* * * *	0CB466	921023 960645 200087 927227	FILTRO SEDIMENTI FONDO DEFLETTORI FARINA TUBO POMPA SCARICO OLIO TUBO OTTURAZIONI	SEDIMENT FILTER DEFLECTORS, FLOUR PIPE DRAIN PUMP OIL UNCLOGGING ROD	



Electrolux Professional SPA
Viale Treviso 15
33170 Pordenone
www.electrolux-professional.com

NordCap GmbH & Co. KG
Thalendorststraße 15
28307 Bremen
Hauptsitz (Service, Finanzen & Personal, Lager, IT, Marketing)

Telefon: +49 421 48557-0
Telefax: +49 421 488650
E-Mail: bremen@nordcap.de

Die NordCap Verkaufsniederlassungen in Deutschland:

Nord: Hamburg • Ost: Berlin • Süd: Ingelheim • West: Erkrath

by **NordCap**[®]

ZANUSSI
PROFESSIONAL