

## Ersatzteilliste-Explosionszeichnung

Schnellkühler / Schockfroster SF 200/170-LW-E



**BLAST CHILLER- FREEZER**

**RANGE BCF ROLL IN 150 - 200 Kg**

| Type Reference   | Ref | Page   | Description  |
|------------------|-----|--------|--|
| <b>SKCH200B</b>  | a   | 2 to 5 | BCF 200/170KG 20 GN 2/1 - ROLL-IN built in 380/400V 50HZ |
| <b>SKCH150B</b>  | b   | 2 to 5 | BCF 150/120KG 20 GN 2/1- ROLL-IN built in 380/400V 50HZ  |
| <b>SKCH150R</b>  | c   | 2 to 5 | BCF 150/120KG 20 GN 2/1- ROLL-IN 380/400V 50HZ           |
| <b>SKCH200R</b>  | d   | 2 to 5 | BCF 200/170KG 20 GN 2/1 - ROLL-IN remote 380/400V 50HZ   |
| <b>SKCHU200R</b> | e   | 2 to 5 | BCF 200/170KG 20 GN 2/1 - ROLL-IN remote USA 208/60hz    |

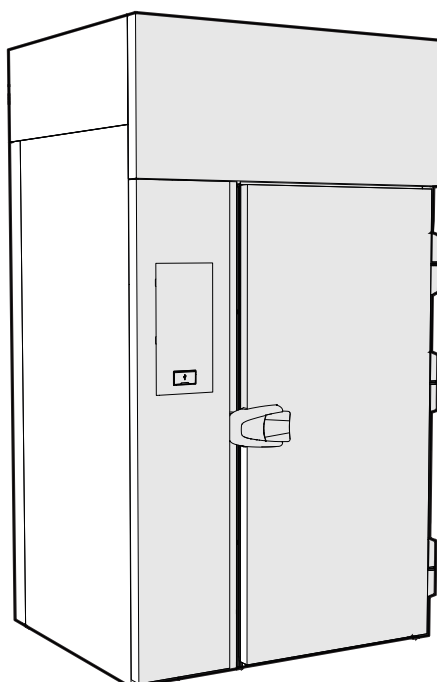

**Index**

|   |         |
|---|---------|
| Identification "type ref"/identificazione "type ref"          | 2       |
| Exploded view body part / Vista esplosa corpo                 | 3       |
| Exploded view evaporator/ Vista esplosa parte evaporante      | 4       |
| Exploded view cooling unit/ Vista esplosa gruppo refrigerante | 5       |
| Control panel/pannello comandi                                | 6       |
| Spare part list/Lista ricambi                                 | 7 to 11 |

...Bold= last change/Grassetto =ultima modifica

Rev. 3

|                                       |                                |         |                          |
|---------------------------------------|--------------------------------|---------|--------------------------|
| From Ser. Nr....<br>Up to Ser. Nr.... | Ed. 2019-05<br>Updated 2024-02 | Page: 1 | <b>Doc No: 595R51900</b> |
|---------------------------------------|--------------------------------|---------|--------------------------|

## How to put in relation the “Type Ref.” reported on the data plate with the “Type reference” reported on the front page of the Spare Part Catalogue:

The “Type Ref.” represents a group of models/brands all with similar technical features, hence possible to be reported under the same scheme in terms of exploded views.

**Electrolux**

### SKCH

**B=UNIT ON BOARD CONDENSING UNIT**  
**R=REMOTE CONDENSING UNIT**

30 = range 30 kg  
 50 = range 50 kg  
 70 = range 70 kg  
 100 = range 100 kg  
 150 = range 150 kg  
 200 = range 200 kg

**SKCH = SKYLINE CHILLER\FREEZER**  
 (EUROPA\SAUDI ARABIA\KOREA)

**SKCHU = SKYLINE CHILLER\FREEZER**  
 (NORD AMERICA)

ES : **SKCH30B** = range 30 kg gn 1\1 with cooling unit (europa etc.)  
**SKCH30R** = range 30 kg gn 1\1 without cooling unit (remote) (europa etc.)  
**SKCHU30B** = range 30 kg gn 1\1 with cooling unit (nord America)  
**SKCHU30R** = range 30 kg gn 1\1 without cooling unit (remote) (nord America)

Find below an identification example: SKCH30B

|   |                           |                   |                                 |
|---|---------------------------|-------------------|---------------------------------|
| F.Mod.<br>PNC 9VTX.....   | Comm.Model<br>Ser.Nr..... | Type Ref. SKCH30B | 2019                            |
| W.Tot. kW   | Volt.....                 | Hz.....           | Cyclopentane<br>Total Current A |
| Evaporation Heater El. kW   | Class x                   | GWP               | CO2-eq t                        |
| Lighting W  | Cap.                      | Refrigerant       | Kg                              |
| Defrost Power kW  | Heating power kW          |                   |                                 |
| NF nominal Charge   |                           |                   |                                 |
| Rated Pressure Mpa  |                           | CE                | WEEE                            |
| IPX4  |                           |                   |                                 |
| Electrolux Professional SPA - Viale Treviso, 15 - 33170 Pordenone (Italy) |                           |                   |                                 |

For the right spare code identification follow the steps:

1. Type in the website the PNC reported on the data plate.
2. The website will automatically display this spare part catalogue.
3. The spare part code at this point is referenced through the “Type reference” as from the front page by the relevant “Ref”.

## Come mettere in relazione il “Type Ref.” Riportato sulla targhetta caratteristica con il “Type reference” riportato sul frontespizio del catalogo ricambi:

Il “Type Ref.” Rappresenta un gruppo di modelli/marchi con simili caratteristiche tecniche, ossia possibili da rappresentare con il medesimo schema in termini di vista esplosa.

**Electrolux**

### SKCH

**B=UNITA' CON GRUPPO**  
**R=UNITA' PREDISPOSTA REMOTA**

30 = MODELLO 30 kg  
 50 = MODELLO 50 kg  
 70 = MODELLO 70 kg  
 100 = MODELLO 100 kg  
 150 = MODELLO 150 kg  
 200 = MODELLO 200 kg

**SKCH = SKYLINE CHILLER\FREEZER**  
 (EUROPA\SAUDI ARABIA\KOREA)

**SKCHU = SKYLINE CHILLER\FREEZER**  
 (NORD AMERICA)

ES : **SKCH30B** = range 30 kg gn 1\1 con gruppo (europa etc.)  
**SKCH30R** = range 30 kg gn 1\1 predisposto remoto (europa etc.)  
**SKCHU30B** = range 30 kg gn 1\1 con gruppo (nord America)  
**SKCHU30R** = range 30 kg gn 1\1 predisposto remoto (remote) (nord America)

Qui di seguito un esempio di identificazione: SKCH30B

|   |                           |                   |                                 |
|---|---------------------------|-------------------|---------------------------------|
| F.Mod.<br>PNC 9VTX.....   | Comm.Model<br>Ser.Nr..... | Type Ref. SKCH30B | 2019                            |
| W.Tot. kW   | Volt.....                 | Hz.....           | Cyclopentane<br>Total Current A |
| Evaporation Heater El. kW   | Class x                   | GWP               | CO2-eq t                        |
| Lighting W  | Cap.                      | Refrigerant       | Kg                              |
| Defrost Power kW  | Heating power kW          |                   |                                 |
| NF nominal Charge   |                           |                   |                                 |
| Rated Pressure Mpa  |                           | CE                | WEEE                            |
| IPX4  |                           |                   |                                 |
| Electrolux Professional SPA - Viale Treviso, 15 - 33170 Pordenone (Italy) |                           |                   |                                 |

Per identificare il corretto codice ricambio procedere con:

1. Digitare nel website il PNC riportato sulla targhetta caratteristica.
2. Il website mostrerà automaticamente questo catalogo ricambi.
3. A questo punto, il codice ricambio è identificabile attraverso il “Type reference” come indicato nel frontespizio sotto la relativa voce “Ref”.

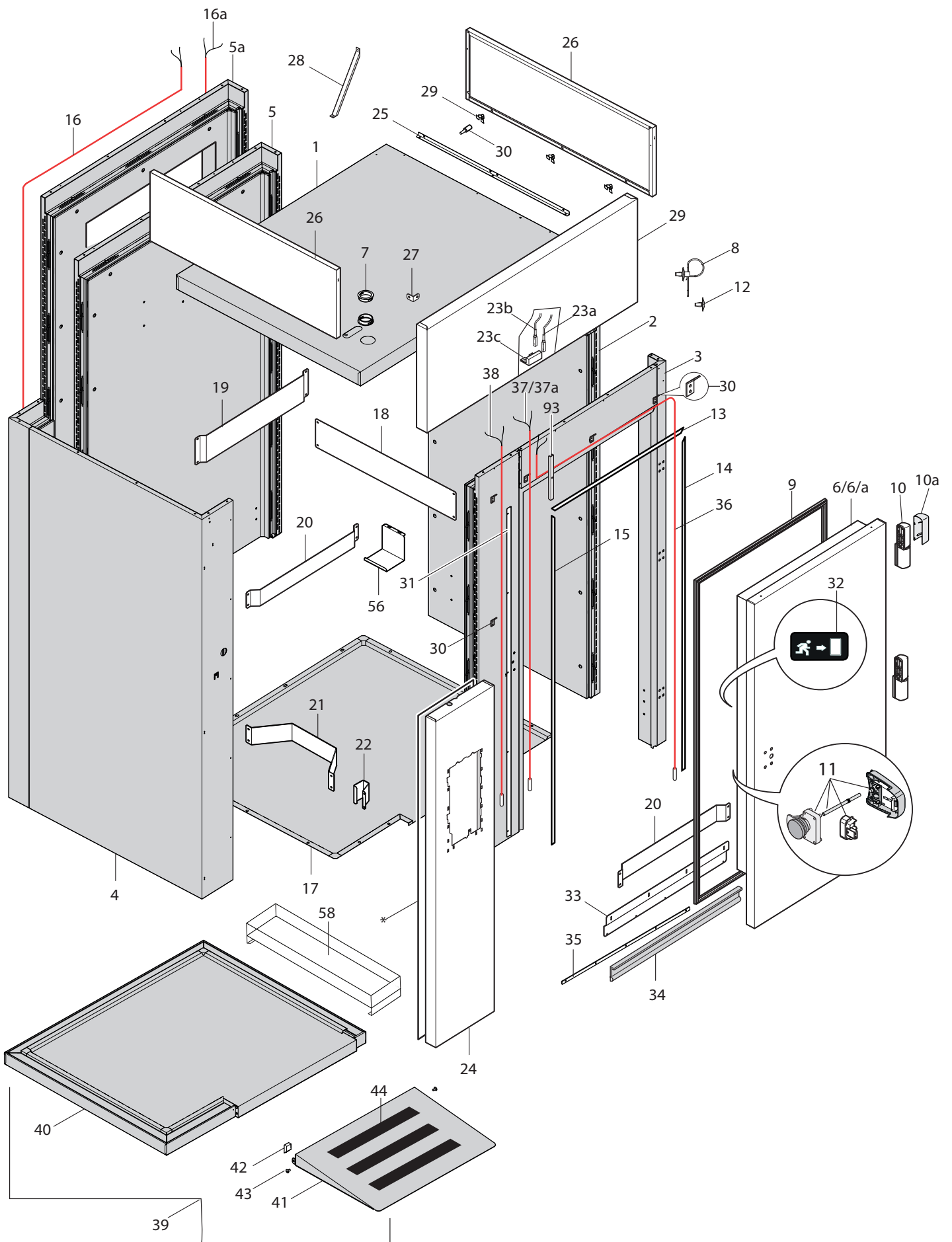

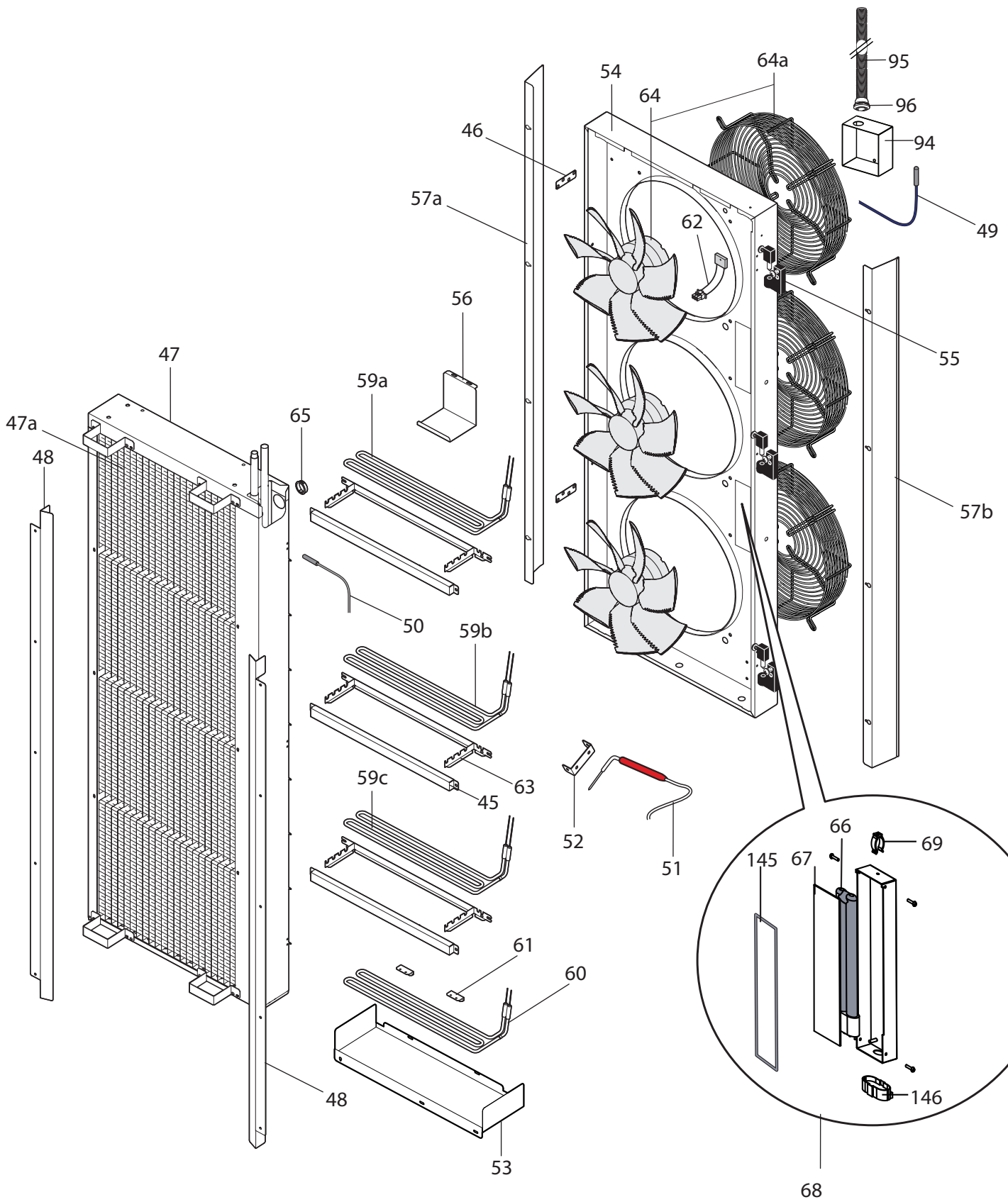

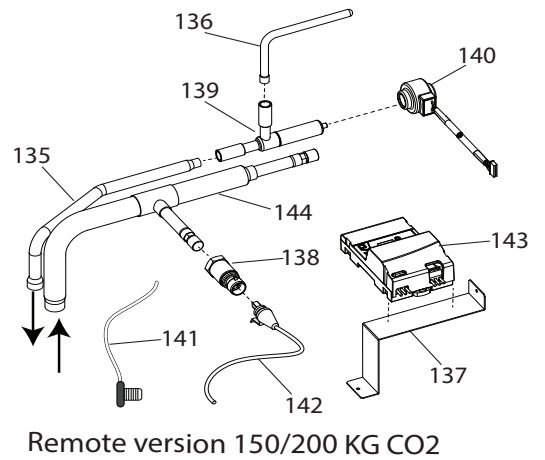
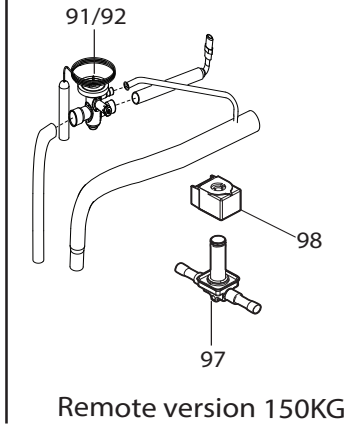
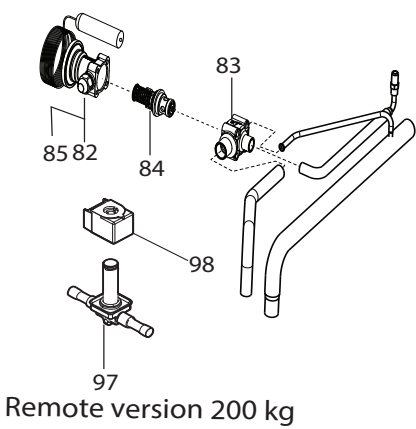
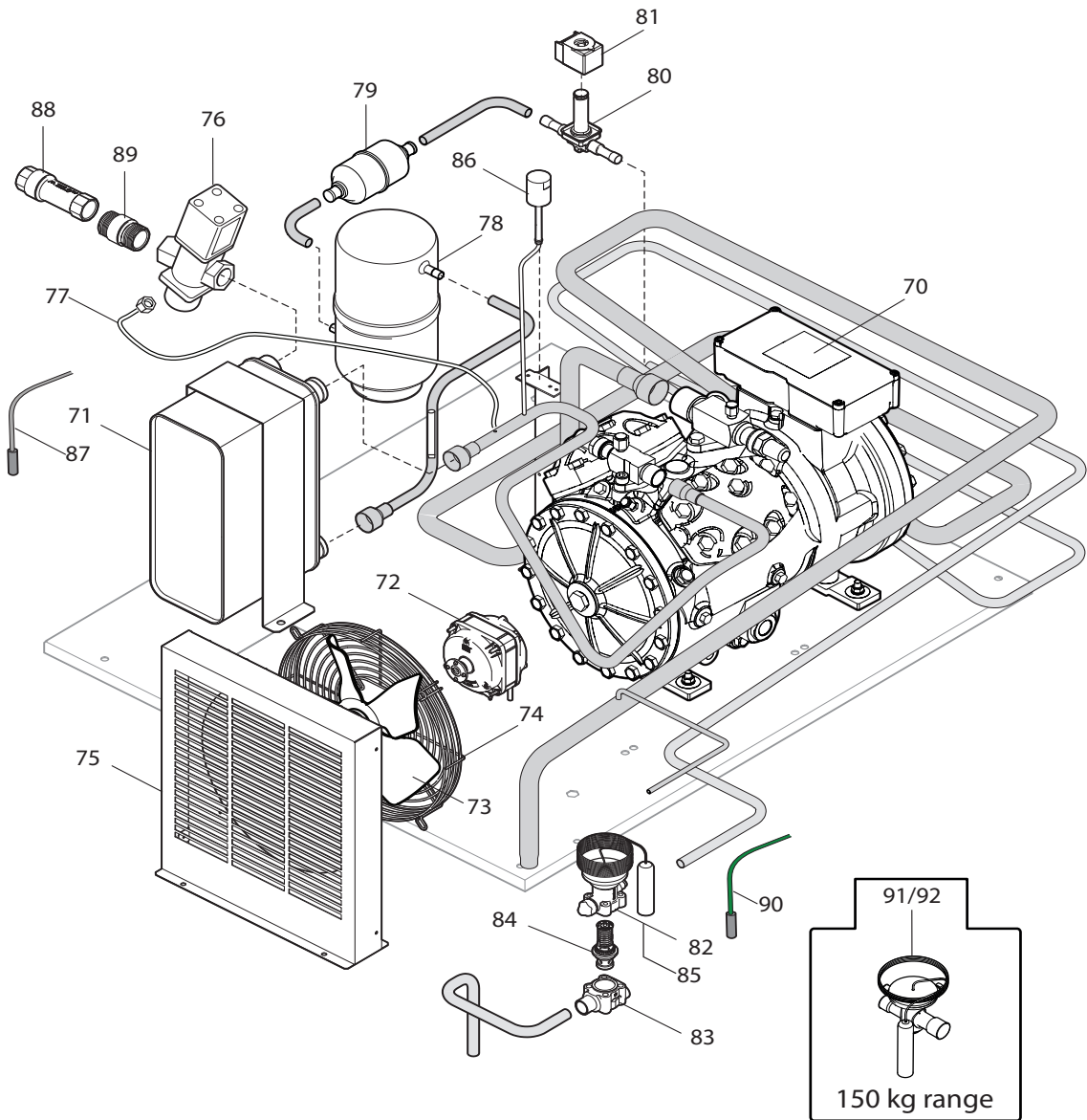

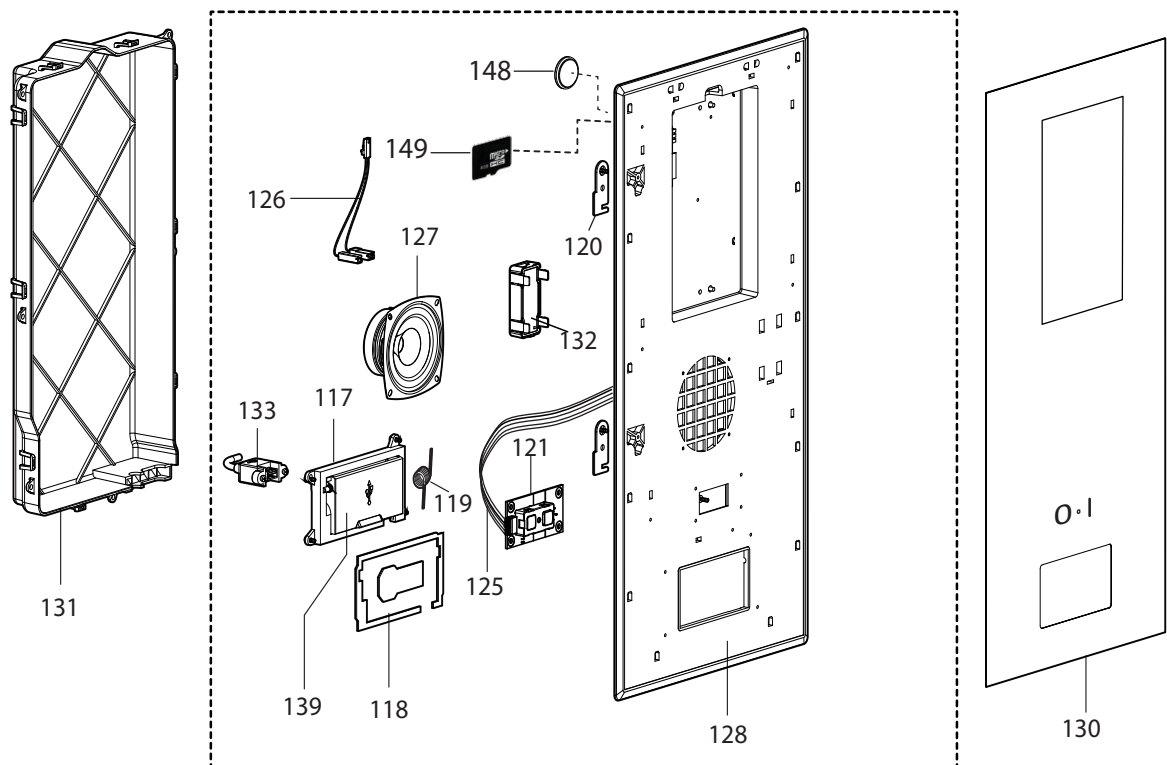
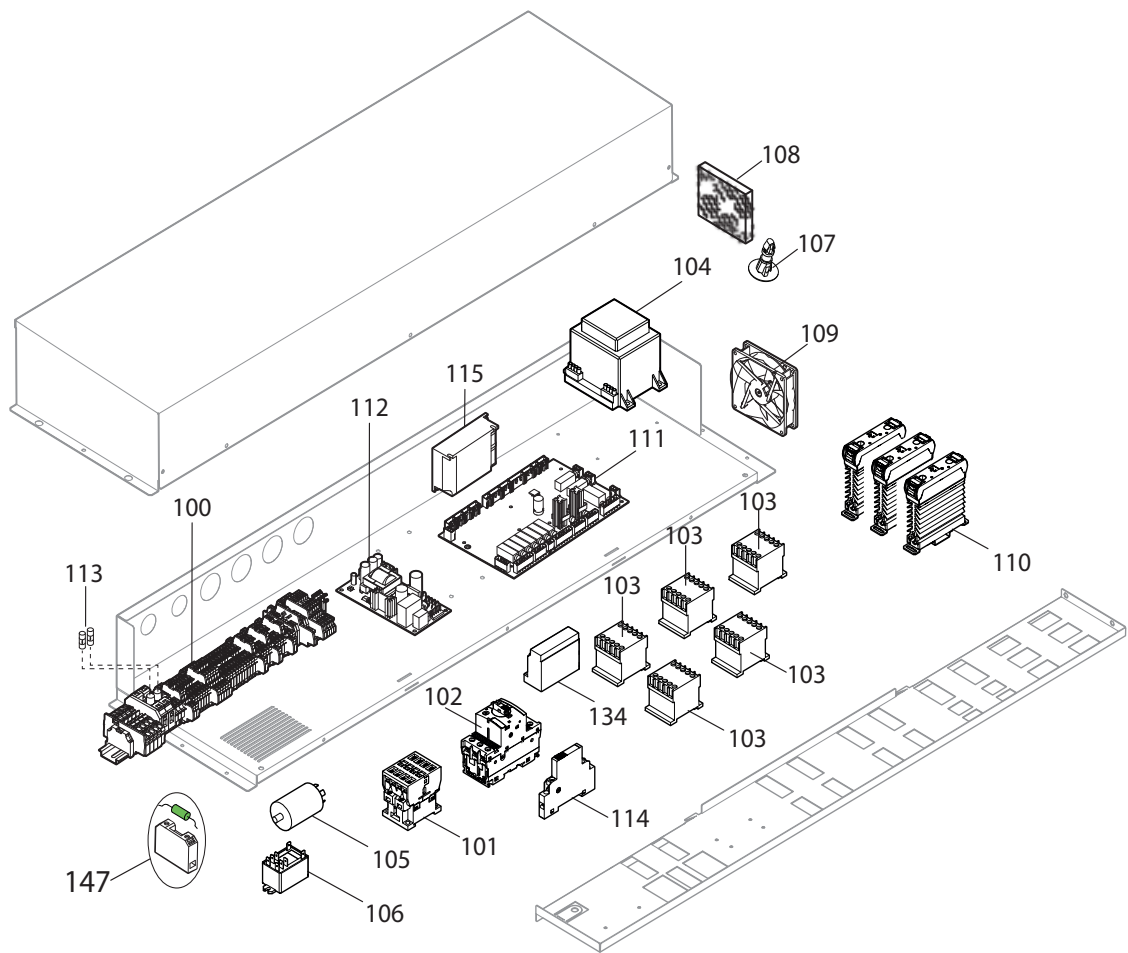

**note:** replacing n°128 order also 130

116

| Pos | Code   | Factory code | Description                              | Descrizione                           | Ref/notes                       |
|-----|--------|--------------|--|---------------------------------------|---------------------------------|
| 1   | 096403 | 0835R72502   | Upper panel                              | Pannello superiore                    |                                 |
| 2   | 096399 | 0835R23503   | Right panel                              | Pannello destro                       |                                 |
| 3   | 096400 | 0835R23604   | Door panel                               | Pannello per porta                    |                                 |
| 4   | 096398 | 0835R74300   | Left panel                               | Pannello sinistro                     |                                 |
| 5   | 096401 | 0835R23802   | Back panel standard                      | Pannello schienale standard           |                                 |
| 5a  | 096402 | 0835R24704   | Back panel to pass-through               | Pannello schienale passante           |                                 |
| 6   | 096505 | 0877789807   | Door standard right                      | Porta dx standard                     |                                 |
| 6a  | 095491 | 0877794303   | Door left to pass-Through                | Porta sx per passante                 |                                 |
| 7   | 0L3177 | 0639735400   | Wiring bush                              | Passacavo uscita cavi                 |                                 |
| 8   | 095928 | 0C03010591   | Opening clamp                            | Fascetta apribile "messicano"         | Up to 2020/21                   |
| 8   |        | 0639622800   | Opening clamp                            | Fascetta apribile "messicano"         | From 2020/22                    |
| 9   | 099168 | 0547751201   | Gasket door 849.5x1815.5                 | Guarnizione porta 849.5x1815.5 mm     |                                 |
| 10  | 094731 | 0833R34900   | Hinge door assembled                     | Cerniera porta completa               |                                 |
| 10a | 097267 |              | Hinge cover                              | Copertura cerniera                    |                                 |
| 11  | 094730 | 0833R34800   | Door closer complete                     | Chiusura porta completa               |                                 |
| 12  | 091507 | 0549741500   | Plug for panels                          | Tappo per pannelli                    |                                 |
| 13  | 093956 | 0501747501   | Frame upper support                      | Cornice traversa superiore            |                                 |
| 14  | 090028 | 0512740401   | Vertical frame "right"                   | Cornice verticale destra              |                                 |
| 15  | 095581 | 0502R17800   | Vertical frame "left"                    | Cornice verticale sx                  |                                 |
| 16  | 096368 | 0617R27000   | Heater frame door right 2680 mm 40.2 W   | Cavo riscaldante dx 2680 mm 40.2 W    | c,d,e pass-through EU-USA       |
| 16a | 096369 | 0617R26900   | Heater frame door left 1850 mm 27.8 W    | Cavo riscaldante sx 1850 mm 27.8 W    | c,d,e pass-through EU-USA       |
| 17  | 096381 | 0882R68101   | Bottom panel                             | Basamento standard                    |                                 |
| 17  |        | 0882R94600   | Bottom panel                             | Basamento standard                    | With insulated floor + ramp     |
| 17  |        | 0883R21200   | Bottom panel                             | Basamento standard                    | Pass-through from 2020/22       |
| 18  | 089842 | 0512759203   | Right side bumper                        | Paracolpi laterale dx                 |                                 |
| 18  | 090163 | 0512777201   | Right side bumper                        | Paracolpi laterale dx                 | Pass-through from 2020/22       |
| 19  | 089843 | 0512759501   | Back upper bumper                        | Paracolpi superiore schienale         |                                 |
| 19  | 090163 | 0512777201   | Back upper bumper                        | Paracolpi superiore schienale         | Pass-through from 2020/22       |
| 20  | 089844 | 0512759402   | Back lower bumper and door bumper        | Paracolpi porta e schienale           |                                 |
| 21  | 096304 | 0504R16000   | Left side bumper                         | Paracolpi sx carter                   | Up to 2020/21                   |
| 21  | 089845 | 0512759102   | Left side bumper                         | Paracolpi sx carter                   | From 2020/22                    |
| 21  | 090164 | 0805770501   | Left side bumper                         | Paracolpi sx carter                   | From 2020/22 pass-through       |
| 22  | 096303 | 0504R14700   | Left inlet bumper                        | Paracolpi sx entrata                  |                                 |
| 23a | 096002 | 0640R04101   | Door microswitch                         | Sensore porta                         |                                 |
| 23b | 095929 | 0646R20601   | Magnetic sensor UV lamp                  | Sensore magnetico lampada UV          | d,e for UV lamp                 |
| 23c | 087533 | 0640712000   | Magnet STEM                              | Magnete STEM                          | d,e UV lamp from 2022/29        |
| 24  | 096328 | 0850R25501   | Vertical control panel electrolux        | Cruscotto verticale electrolux        | electrolux                      |
| 24  | 096371 | 0850R25601   | Vertical control panel other brand       | Cruscotto verticale other brand       | all brand                       |
| 25  | 096196 | 0505R12601   | Support corner                           | Angolare fissaggio laterale           |                                 |
| 26  | 093957 | 0512748506   | Upper side panel "left and right"        | Pannelli superiori dx e sx            | a,b                             |
| 26  | 094758 | 0512748906   | Upper side panel "left and right"        | Pannelli superiori dx e sx            | c,d,e                           |
| 27  | 096197 | 0505R15000   | Upper small bracket for upper side panel | Staffa piccola per pannelli superiori |                                 |
| 28  | 0TTZXM | 0505R13100   | Upper bracket for upper side panel       | Staffa per pannelli superiori         |                                 |
| 29  | 096346 | 0509R25800   | Upper Dashboard                          | Pannello superiore                    | a,b up to 2022/28               |
| 29  | 097534 | 0509R25801   | Upper Dashboard                          | Pannello superiore                    | a,b from 2022/29                |
| 29  | 095604 | 0509R15204   | Upper Dashboard                          | Pannello superiore                    | c,d,e up to 2020/26             |
| 29  |        | 0509R15301   | Upper Dashboard                          | Pannello superiore                    | c,d,e pass-through from 2020/27 |
| 30  | 093793 | 0505R12800   | Bracket for upper dashboard              | Staffetta per cruscotto superiore     |                                 |



| Pos        | Code          | Factory code      | Description                               | Descrizione  | Ref/notes             |
|------------|---------------|-------------------|---|--|-----------------------|
| 31         | 094761        | 0501R63501        | Vertical protection heater                | Protezione verticale resistenza                    |                       |
| 32         | 094732        | 0598R66200        | Sticker internal door                     | Adesivo interno porta                              | Up to 2020/21         |
| 32         |               | 0598R97900        | Sticker internal door                     | Adesivo interno porta                              | From 2020/22          |
| 33         | 090029        | 0512748101        | Lower gasket support door                 | Guida guarnizione porta inferiore                  |                       |
| 34         | 099167        | 0547748701        | Lower gasket door                         | Guarnizione inferiore porta                        |                       |
| 35         | 089840        | 0512748003        | Gasket lower support door                 | Supporto inferiore guarnizione porta               |                       |
| 36         | 096347        | 0617R26301        | Heater frame door right 2700 mm 40.2 W    | Cavo riscaldante dx 40.2 W                         |                       |
| 36         |               | 0617R03H00        | Heater fr. door right 43.2 W 2880 mm      | Cavo riscaldante dx 43.2 W                         | d 2x20                |
| 37         | 096361        | 0617R28000        | Heater frame door left 27.8 W 3350 mm     | Cavo riscaldante cornice sx 27.8 W                 |                       |
| 37a        | 096347        | 0617R26301        | Heater fr. used with ramp 40.2 W 2700 mm  | Cavo riscaldante dx e con rampa 40.2 W             |                       |
| 38         | 096200        | 0617R26200        | Heater left door panel 27.8 W 2850 mm     | Cavo riscaldante pannello 27.8 W                   |                       |
| 39         | 096540        | 0835R32Q00        | Foamed bottom complete                    | Ass. fondo schiumato completo                      |                       |
| 40         | 096214        | 0835R34901        | Foamed bottom                             | Fondo schiumato                                    |                       |
| 41         | 096213        | 0833R27900        | Ramp                                      | Rampa  |                       |
| 42         | 096195        | 0502R40700        | Heater frame cover ramp                   | Protezione resistenza rampa                        |                       |
| 43         |               | 0217045145        | Screws M8X16 AISI 304                     | Vite M8X16 AISI 304                                |                       |
| 44         | 096316        | 0546R31700        | Anti-slip roll                            | Rotolo antiscivolo                                 |                       |
| 45         | 096194        | 0501R47400        | Heater hand protection                    | Protezione mani resistenze                         |                       |
| 46         | 096198        | 0505R15100        | Locking bracket                           | Piattina di chiusura                               |                       |
| 47         | 096380        | 0858R17601        | Evaporator with covers in stainless steel | Evaporatore con coperture                          |                       |
| 47         | 097262        | 0858R18600        | Evaporator with covers in stainless steel | Evaporatore con coperture                          | c,d CO2               |
| <b>47a</b> | <b>089859</b> | <b>0840706703</b> | <b>Evaporator</b>                         | <b>Evaporatore</b>                                 |                       |
| <b>47a</b> | <b>097622</b> | <b>0830R02T00</b> | <b>Evaporator</b>                         | <b>Evaporatore</b>                                 | <b>c,d CO2</b>        |
| 48         | 093824        | 0501R46300        | Vertical splash guard right_left          | Paraspruzzi verticale evaporatore                  |                       |
| 49         | 096205        | 0646R21600        | Cavity sensor blu color                   | Sonda 6X20 blu 'CELL' resinata                     |                       |
| 50         | 096206        | 0646R21700        | Evaporator sensor grey color              | Sonda 6X20 grigia 'evaporatore' resinata           |                       |
| 51         | 096208        | 0646R22200        | Food probe 3 sensors                      | Spillone conico 3 punti                            | a,b,c,d               |
| 51         | 096431        | 0653R00000        | Food probe 3 sensors                      | Spillone conico 3 punti                            | e                     |
| 52         | 089860        | 0506748800        | Food probe support                        | Supporto sonda spillone                            |                       |
| 53         | 093823        | 0805768305        | Evaporator water collector                | Bacinella raccolta condensa evaporatore            | Up to 2020/21         |
| 53         | 096555        | 0805R00H01        | Evaporator water collector                | Bacinella raccolta condensa evaporatore            | From 2020/22          |
| 54         | 096193        | 0858759802        | Carter evaporator                         | Carter evaporatore                                 | Up to 2020/26         |
| 54         | 096554        | 0850R04A00        | Carter evaporator                         | Carter evaporatore                                 | From 2020/27          |
| <b>54</b>  | <b>097527</b> | <b>0501R73402</b> | <b>Carter evaporator</b>                  | <b>Carter evaporatore</b>                          | <b>e with UV lamp</b> |
| 55         | 090040        | 0830764200        | Carter hinge                              | Cerniera carter evaporatore                        |                       |
| 56         | 096308        | 0504R16900        | Wiring protection                         | Protezione cavi evaporatore                        |                       |
| 57         | 096192        | 0512716401        | Air conveyor                              | Convogliatore aria                                 | Up to 2020/21         |
| 57a        | 096544        | 0504R19201        | Left air conveyor                         | Convogliatore aria sx                              | From 2020/22          |
| 57b        | 097041        | 0502R08L00        | Right air conveyor                        | Convogliatore aria dx                              | From 2020/22          |
| 58         | 091292        | 0833R12600        | Water manual collector                    | Bacinella manuale di raccolta condensa             |                       |
| 59a        | 097258        | 0617R03S00        | Upper defrost heater 1000 Watt 230V       | Resistenza di sbrinamento superiore 1000 Watt 230V | a,b,c,d               |
| 59a        | 093231        | 0617727701        | Upper defrost heater 1000 Watt 208V       | Resistenza di sbrinamento superiore 1000 Watt 208V | e                     |
| 59b        | 097257        | 0617R03R00        | Central defrost heater 1000 Watt 230V     | Resistenza di sbrinamento centrale 1000 Watt 230V  | a,b,c,d               |
| 59b        | 093231        | 0617727701        | Central defrost heater 1000 Watt 208V     | Resistenza di sbrinamento centrale 1000 Watt 208V  | e                     |

| Pos       | Code          | Factory code      | Description   | Descrizione  | Ref/notes               |
|-----------|---------------|-------------------|---|--|-------------------------|
| 59c       | 093228        | 0617724102        | Lower defrost heater 1000 Watt 230V                 | Resistenza di sbrinamento inferiore 1000 Watt 230V     | a,b,c,d                 |
| 59c       | 093231        | 0617727701        | Lower defrost heater 1000 Watt 208V                 | Resistenza di sbrinamento inferiore 1000 Watt 208V     | e                       |
| 60        | 089863        | 0617724001        | Bottom evaporator heater 1500 Watt 230V             | Resistenza sotto evaporatore 1500 Watt                 | a,b,c,d                 |
| 60        | 096356        | 0617R27500        | Bottom evaporator heater 1500 Watt 208V             | Resistenza sotto evaporatore 1500 Watt                 | e                       |
| 61        | 095762        | 0512717400        | Stopper bottom evaporator heater                    | Fissaggio resistenza sotto evaporatore                 |                         |
| 62        | 096210        | 0652R02601        | Safety thermostat 93°C 120 VDE                      | Termofusibile 93°C VDA                                 | a,b,c,d                 |
| 62        | 096365        | 0652R02901        | Safety thermostat 93°C 120 UR                       | Termofusibile 93°C UR                                  | e                       |
| 63        | 096191        | 0512713501        | Defrost heater support                              | Supporto resistenza                                    |                         |
| 64        | 084914        | 0682708602        | Cavity fan 400V 50/60Hz 1350/1050Rpm                | Ventilatore cella 400V 50/60Hz 540/360W                | a,b,c,d                 |
| 64        | 099172        | 0682719401        | Cavity fan 208V 50/60Hz 1350/1050Rpm                | Ventilatore cella 208V 50/60Hz 540/360W                | e                       |
| 64a       | 096311        | 0514R29200        | Protection cavity fan aisi                          | Griglia di protezione ventilatore AISI                 | e                       |
| 65        | 094001        | 0639711100        | Wiring hole protection                              | Passacavo  |                         |
| 66        | 093949        | 661R01100         | UV lamp 18W2G11                                     | Lampada UV 18 W  |                         |
| 67        | 093097        | 549R05400         | Glass for uv lamp                                   | Vetro per lampada UV                                   |                         |
| <b>68</b> | <b>097537</b> | <b>0832R28500</b> | <b>ASS. UV LAMP</b>                                 | <b>ASSIEME LAMPADA</b>                                 | <b>e with UV lamp</b>   |
| <b>69</b> | <b>084384</b> | <b>0624705200</b> | <b>PLASTIC SPRING</b>                               | <b>MOLLE PE LAMPADA</b>                                | <b>e with UV lamp</b>   |
| 70        | 096212        | 0684R13500        | Compressor H751CS                                   | Compressore H751CS                                     | a                       |
| 70        | 097074        | 0684R15100        | Compressor H505CS                                   | Compressore H505CS                                     | b                       |
| 70        | 096549        | 0684R13400        | Compressor H705CS                                   | Compressore H705CS                                     | b 60 Hz                 |
| 70        | 096550        | 0684R15000        | Compressor H751CS                                   | Compressore H751CS                                     | a 60 Hz                 |
| 71        | 084899        | 0830766700        | H2O condenser B10THx 70P                            | Condensatore ad acqua B10THx 70P                       | a                       |
| 71        | 084939        | 0830763700        | H2O condenser B10THx 40P                            | Condensatore ad acqua B10THx 40P                       | b                       |
| 72        | 096211        | 0682R13600        | Fan condenser motor                                 | Ventilatore condensatore                               |                         |
| 73        | 084781        | 0511704700        | Fan D 254/28°                                       | Ventola D 254/28°                                      |                         |
| 73        | 094955        | 0511R01900        | Fan D 254/31°                                       | Ventola D 254/31°                                      | a,b 60 Hz               |
| 74        | 092651        | 0514R07500        | Grid protection fan condenser                       | Griglia ventilatore                                    |                         |
| 74        | 096468        | 0514R05A00        | Grid protection fan condenser                       | Griglia ventilatore                                    | a,b 60 Hz               |
| 75        | 096343        | 0504R03701        | Support protection fan                              | Protezione ventilatore                                 |                         |
| <b>76</b> | <b>092277</b> | <b>0646R09100</b> | <b>Pressostatic valve H2O V46 AC 9300</b>           | <b>Valvola pressostatica H2O V46 AC 9300</b>           | <b>Up to 2024/05</b>    |
| <b>76</b> | <b>09A1NB</b> | <b>0646R07A00</b> | <b>Pressostatic valve DANFOSS WVFX10 (003N1105)</b> | <b>Valvola pressostatica DANFOSS WVFX10 (003N1105)</b> | <b>From 2024/06</b>     |
| 77        | 096199        | 0515R22300        | Cappillary 1.5M 1/4' for press. valve               | Cappillare 1,5 M racc. 1/4' press.valvola              |                         |
| 78        | 083468        | 0805725601        | Tanic reciver LT 2.3                                | Recivitore di liquido LT 2.3                           |                         |
| 79        | 090046        | 0805766400        | Filter DLC  | Filtro DLC   |                         |
| 80        | 089867        | 0646759600        | EVR 10 Valve 12 mm                                  | Valvola EVR 10 12mm                                    |                         |
| 81        | 088351        | 0646749000        | BoB.clip 10W EVR6 230/230 50/60hz                   | Bobina 10W EVR6 230/230 50/60hz                        |                         |
| 82        | 085447        | 0646729600        | Thermostatic element TES5 67B3357                   | Elemento termostatico TES5 67B3357                     | a,d (gas R452/404)      |
| 82        | 096364        | 0646R23200        | Thermostatic element TES5 067B3252                  | Elemento termostatico TES5 67B3357                     | d,e (gas R448/449/407c) |
| 83        | 096202        | 0646R20400        | Body Valve to solder 067B4002 12/16                 | Corpo valvola a saldare 067B4002 12/16                 | a,d,e                   |
| 84        | 084906        | 0646727300        | Orifice 02 67B2790                                  | Orificio valvola N°2 67B2790                           | a,d,e                   |
| 85        | 096315        | 0544R10000        | Insulation valve, thermich insulation               | Protezione valvola , isolamento termico                | a,d,e                   |
| 86        | 096201        | 0646R20300        | Pressostat AC 250V OFF 31 bar On 24 bar             | Pressostato 250V OFF 31 bar On 24 bar                  |                         |
| 87        | 096204        | 0646R21500        | Probe condenser Black                               | Sond condensatore nera                                 |                         |
| 87        | 096321        | 0646R22300        | Probe condenser Black                               | Sonda condensatore nera                                | e                       |
| 88        | 0L2980        | 0652608800        | Double non-return valve AVG 2NV20-20 FXF            | Doppia valvola di ritegno AVG 2NV20-20 FXF             |                         |
| 89        | 072457        | 0W00526300        | Joint 3/4X3/4MM                                     | Raccordo 3/4X3/4MM                                     |                         |
| 90        | 096207        | 0646R21800        | OUT probe green color                               | Sonda "OUT evap" di colore verde                       |                         |
| 91        | 096203        | 0646R20500        | Thermost. valve or.3 con attacchi1/2 x 5/8          | Valvola termost. or.3 con attacchi1/2 5/8              | b,c R452a/404a          |

| Pos        | Code          | Factory code      | Description   | Descrizione  | Ref/notes                           |
|------------|---------------|-------------------|---|--|-------------------------------------|
| 92         | 096314        | 0544R09900        | Insulation valve, thermich insulation                                 | Protezione valvola , isolamento termico                          | b,c                                 |
| 93         | 096306        | 0504R16600        | Heating cables cover BCF 150/200 JJ                                   | Protezione cavi bcf  |                                     |
| 94         | 096300        | 0504R12601        | Protection box cavity fan UL  | Calotta di protezione ventilatore cella UL                       | e                                   |
| <b>95</b>  | <b>097538</b> | <b>0835R76600</b> | <b>Flexible metal conduit SS L=0.27m UL</b>                           | <b>Tubo in ss per cavi ventilatori UL</b>                        | <b>e</b>                            |
| 96         | 096313        | 0544R09800        | Connection of fitting and conduit M20x15                              | Raccordo per tubo in SS ventilatori UL                           |                                     |
| 97         | 089867        | 0646759600        | EVR 10 Valve 12 mm usa UL   | Valvola EVR 10 12mm UL   |                                     |
| 98         | 099180        | 0858741600        | BoB.coil 208-240V 50-60HZ UL  | Bobina 10W EVR6 230/230 50/60hz UL                               | e                                   |
| 100        | 096362        | 0639R21701        | Complete clamp /150/200 kg  | Morsettiera completa 150/200KG                                   | a,b                                 |
| 100        | 096319        | 0639R22002        | Complete clamp /150/200 kg  | Morsettiera completa 150/200KG                                   | c,d,e                               |
| 101        | 090064        | 0648729600        | Contacto B&J K3-22 A10-230  | Contattore B&J K3-22 A10-230                                     | a,b,c,d                             |
| 102        | 096322        | 0648R11500        | Motor protective switch MS132-25 (20-25A)                             | Salvatore ABB MS132-25 (20-25A)                                  | a                                   |
| 102        | 093194        | 0640R01900        | Motor protective switch MS132-20 (16-20A)                             | Salvatore ABB MS132-20 (16-20A)                                  | b                                   |
| 103        | 088557        | 0648727100        | Contacto K1-09D10 230 (COIL 220-230/50 240/60)                        | Teleruttore K1-09D10 230 (COIL 220-230/50 240/60)                | a,b,c,d                             |
| 103        | 090099        | 0648729300        | Contacto K1-09D10 230 (COIL 200/50 240/60)                            | Teleruttore K1-09D10 230 (COIL 200/50 240/60)                    | e                                   |
| 104        | 093625        | 0624R01700        | Voltage adaptor 230/42V 170VA   | Trasformatore 230/42V 170VA                                      | a,b,c,d                             |
| 104        | 096430        | 624R00A00         | Voltage adaptor 208/42V 170VA   | Trasformatore 208/42V 170VA                                      | e                                   |
| 105        | 084987        | 0694700800        | Filter ( L.C)   | Filtro elettrico 411.5.14.41.0 (TIPO L-C)                        | a,b - c,d up to 2020/21 - d UV lamp |
| 105        | 059078        | 0694502400        | Filter ( L.C)   | Filtro elettrico 411.5.24.41.0D (TIPO L-C)                       | c,d from 2020/22                    |
| 106        | 093848        | 0648R06300        | Relay 66.82.8.230.0001  | Relè 66.82.8.230.0001  |                                     |
| 107        | 095984        | 0546401600        | Clip for board  | Distanziale per scheda   |                                     |
| 108        | 096312        | 0514R29600        | Electric box filter   | Filtro scatola elettrica   | a,b,c,d 50 Hz                       |
| 109        | 0CA716        | 0682400300        | Assial fan 92x25  | Ventilatore assiale 92x25  | Up to 2020/21                       |
| 110        | 096209        | 0648R11100        | Relay 50A + heat sink   | Relè con dissipatore 50A   |                                     |
| 111        | 096010        | 0648R08602        | ACU PETRA BCF   | Scheda principale PETRA  | Up to 2020/19 canceled              |
| 111        | 096557        | 0648R10900        | ACU PETRA BCF   | Scheda principale PETRA  | From 2020/21                        |
| 112        | 095639        | 0648R10000        | Main board power supply 12V 30W                                       | Scheda principale di potenza 12V 30W                             | a,b,c,d                             |
| 112        | 096342        | 0648R11400        | Main board power supply 12V 54W UL                                    | Scheda principale di potenza 12V 54W                             | e                                   |
| 113        | 095933        | 0652R02400        | Glass fuse 10A T 5x20   | Fusibile in vetro 5X20   |                                     |
| 113        | 0L3083        | 0652608900        | Fuse 10A T 5x20 250V  | Fusibile ceramico 5X20   | a,b, 60Hz - e                       |
| 114        | 091725        | 640R01000         | Ausiliary contactor HK-11   | Contatto ausiliario per slavamotore HK-11                        |                                     |
| 115        | 093950        | 624R01600         | Electronich power UV light 188700                                     | Alimentatore elettronico per UV lampada                          | for UV lamp                         |
| <b>115</b> | <b>097536</b> | <b>0624R00J00</b> | <b>Electronich power UV light 188700</b>                              | <b>Alimentatore elettronico per lampada UV</b>                   | <b>e for UV lamp</b>                |
| <b>116</b> | <b>0CK685</b> | <b>083040PG01</b> | <b>Ass. TOUCH UI ELUX predisposed with ethernet direct connection</b> | <b>Pannello completo UI predisposto con connessione ethernet</b> |                                     |
| 117        | 0CK030        | 0546400U00        | Drawer slot USB   | Ckm sede per Usb   |                                     |
| 118        | 0CK031        | 0543401P02        | Gasket drawer slot USB  | Guarnizione per sede supporto USB                                |                                     |
| 119        | 0CK032        | 0514405000        | Spring drawer slot USB  | Molla per sede supporto USB                                      |                                     |
| 120        | 0CK432        | 0506405M00        | Hook/support for Cmk Touch UI   | Gancio per pannello di controllo                                 |                                     |
| 121        | 0CK033        | 0675401G00        | CKM ON/OFF board  | Scheda ON/OFF  |                                     |
| 125        | 0CK045        | 0675401Q00        | CKM ON/OFF board wiring   | Cavetto scheda ON/OFF  |                                     |
| 126        | 0CK330        | 0675401L00        | Speaker wiring  | Cavetto speaker  |                                     |
| 127        | 0CK039        | 0655400000        | Speaker 4 ohm   | Speaker 4 ohm  |                                     |
| 128        | 0CK040        | 0543401N01        | Plastic frame touch   | Pannello in plastica touch                                       |                                     |
| 129        | 0CK041        | 0546400V00        | Cover slot USB  | Sportello USB  |                                     |
| 130        | 095934        | 0755R13902        | Adhesive decor Electrolux   | Membrana Electrolux  | electrolux                          |
| 130        | 095935        | 0755R16103        | Adhesive decor Zanussi  | Membrana Zanussi   | zanussi                             |
| 130        | 095936        | 0755R16202        | Adhesive decor Alpeninox  | Membrana Alpeninox   | alpeninox                           |
| 130        | 0CK332        | 0541401V02        | Adhesive decor To brand   | Membrana To brand  | to brand                            |
| 131        | 0CK161        | 0541401D01        | Protection comand panel   | Copertura pannello comandi touch                                 |                                     |

| Pos | Code   | Factory code | Description                                | Descrizione                              | Ref/notes  |
|-----|--------|--------------|--|--|--|
| 132 | 0CK042 | 0875406301   | WI Board /NIU                              | WI Board /NIU                            |  |
| 133 | 0CK037 | 0638404D00   | USB wiring L 450 mm                        | Cavo USB L450 mm                         |  |
| 134 | 096412 | 0640R00000   | Diagnose Kriwan switch INT69-2CB           | Modulo Kriwan INT69-2CB-DIAGNOSE         |  |
| 135 | 097255 | 0515R45600   | CU pipe evaporator to thermostatic valve   | Tubo evaporatore-valvola termostatica    | c,d CO2  |
| 136 | 097020 | 0515R45101   | Inlet pipe for thermostatic valve          | Tubo ingresso valvola termostatica       | c,d CO2  |
| 137 | 097254 | 0505R08U00   | Support for mini EVD                       | Supporto per mini EVD                    | c,d CO2  |
| 138 | 097031 | 0646R06K01   | Pressure sensor 90 bar                     | Sensore pressione 90 bar                 | c,d CO2  |
| 139 | 097260 | 0646R06J00   | Thermostatic valve                         | Valvola di espansione elettronica        | c,d CO2  |
| 140 | 097034 | 0805R00L01   | Unipolar stator                            | Statore unipolare da 1m per e2v%u        | c,d CO2  |
| 141 | 097032 | 0646R06L01   | Sensor ntc hf l=1.80mt                     | Sensore ntc hf l=1.80mt                  | c,d CO2  |
| 142 | 097027 | 0634R01S01   | Cable awg 3 wires L=2m for pressure sensor | Cavo AWG per sensore di pressione L=2m   | c,d CO2  |
| 143 | 097033 | 0648R02A01   | Driver EVD mini 115/230v with display      | Driver EVD mini 115/230v con display     | c,d CO2  |
| 144 |        | 0805R00X00   | Pipes subassembly                          | Assieme tubi                             | c,d CO2  |
| 145 | 093946 | 0559R01800   | <b>Front gasket</b>                        | <b>Guarnizione lampada</b>               | <b>e with UV lamp</b>                                    |
| 146 | 093948 | 0665R01100   | <b>UV support</b>                          | <b>Supporto lampada</b>                  | <b>e with UV lamp</b>                                    |
| 147 | 097657 | 0835R33T00   | <b>KIT UV LAMP RECOVERY</b>                | <b>KIT UV LAMP RECOVERY</b>              | <b>UV lamp from 2022/29 - See Tech. Sheet VTX2022_02</b> |
| 148 |        |              | <b>BATTERY CR2032 V3 LITIO</b>             | <b>BATTERIA MODELLO CR 2032 V3 LITIO</b> |  |
| 149 | 0CK674 | 675403M00    | <b>MICRO SD 4G o more biger 4HC</b>        | <b>MICRO SD 4G o piu' grande 4HC</b>     |  |
| *   | 097122 | 0878R08800   | Fan Motor Operation conversion KIT         |  |  |

Electrolux Professional SpA  
Viale Treviso, 15  
33170 Pordenone, ITALY  
Fax (+39) 0434 380 201  
<https://www.electroluxprofessional.com>  
<https://webgate.electroluxprofessional.com>

**Finanzen / Service**

**28307 Bremen**  
Thalendorststraße 15  
Tel.+49 421 48557-0  
Fax+49 421 488650  
bremen@nordcap.de

**Vertrieb Ost**

**12681 Berlin**  
Wolfener Straße 32/34, Haus K  
Tel.+49 30 936684-0  
Fax+49 30 936684-44  
berlin@nordcap.de

**Vertrieb West**

**40699 Erkrath**  
Max-Planck-Straße 30  
Tel.+49 211 540054-0  
Fax+49 211 540054-54  
erkrath@nordcap.de

**Vertrieb Nord**

**21079 Hamburg**  
Großmoorbogen 5  
Tel.+49 40 766183-0  
Fax+49 40 770799  
hamburg@nordcap.de

**Vertrieb Süd**

**55218 Ingelheim**  
Hermann-Bopp-Straße 4  
Tel.+49 6132 7101-0  
Fax+49 6132 7101-20  
ingelheim@nordcap.de



[www.nordcap.de](http://www.nordcap.de)