

Ersatzteilliste-Explosionszeichnung

Schnellkühler / Schockfroster SF 100/65-CW CRI O CHILL



INDEX - INDICE

PAG.

CABINET AND DOOR	3
SPARE PART LISTS - CABINET AND DOOR	4
COOLING UNIT AND CONTROL PANEL	5
SPARE PART LISTS - COOLING UNIT AND CONTROL PANEL	6

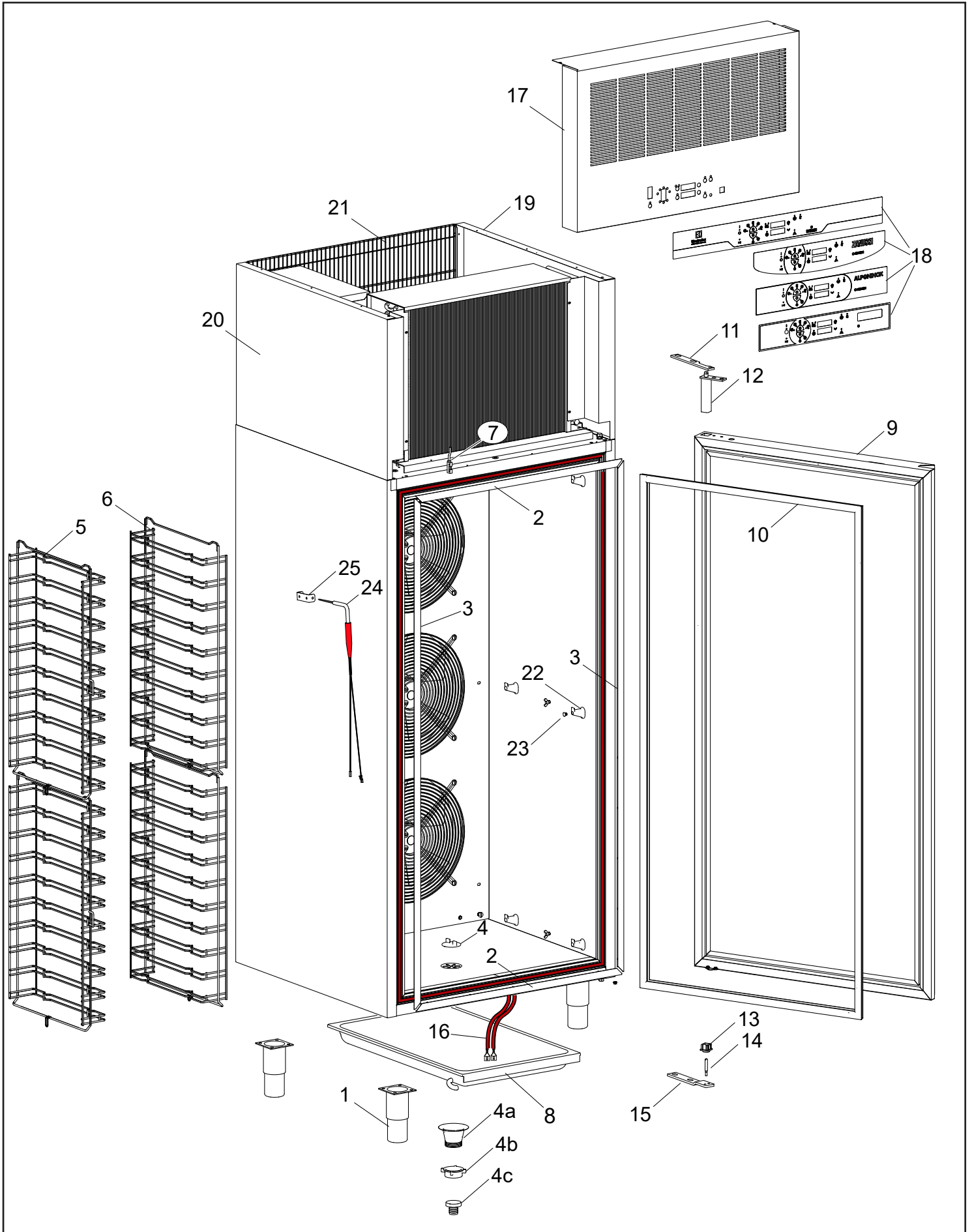

CABINET AND DOOR

From Ser. Nr.
Up to Ser. Nr.

Ed. 01 2023-03
Ed. 01 2023-03

Page: 3 @

Doc No:595R07L00

POS	FACTORY CODE	S.P. CODE	DESCRIPTION	V	W&T	REF.	NOTES	S/N BREAK (YYYY/WK)
1	0855631900	048579	Feet	x				
2	0505783800	099840	Horizontal frame	x				
3	0505783900	091671	Vertical frame	x				
4	0546R27300	093934	Plug for pipe		x			
4a	0546R25400	094255	Discharge pipe		x			
4b	0546R26900	094257	Nut		x			
4c	0546R26200	094256	Rubber support for pipe		x			
5	0514R31801	097708	Left shelf rack	x				
6	0514R31901	097709	Right shelf rack	x				
7	0640R00D00	097671	Door microswitch	x				
8	0242452410	080803	Water condenser basin		x			
9	0835R80902	097720	Door assembly	x				
10	0547771101	099637	Door gasket	x				
11	0505723803	082257	Upper bracket	x				
12	0835704001	082219	Upper hinge door	x				
13	0544700601	081654	Bush for lower hinge door	x				
14	0506713002	082962	Lower pin for hinge	x				
15	0506759400	085772	Lower bracket	x				
16	0617703403	089953	Heating cable		x			
17	0800R00F02	097717	Control panel without components		x	d; e; f	EPR	
17	0800R00D02	097716	Control panel without components		x	a; b; c; g; h; i	ZAN, APX, TO BRAND	
18	0755R16800	097668	EPR control sticker	x		d; e; f	EPR	
18	0755R16900	097667	ZAN control sticker	x		a; b; c	ZAN	
18	0755R17001	097683	APX control sticker	x		i	APX	
18	0755R17100	097666	To brand control sticker	x		g; h	TO BRAND	
*	0755R17200	097684	Logo for Engefood sticker	x		g	Engefood	
19	0504R38001	097704	Upper right side		x			
20	0504R37901	097703	Upper left side		x			
21	009766801	097715	Protection upper rear grid		x			
22	0546703702	083838	Hook racks support	x				
23	0546704200	083839	Plug for hook support		x			
24	0646R06Z00	097682	One sensor food probe	x				
25	0506748800	089860	Food probe support		x			

SPARE PARTS CODE - CABINET AND DOOR

* On demand

Bold=last change

From Ser. Nr. Up to Ser. Nr.	Ed. 01 2023-03 Ed. 01 2023-03	Page: 4	Doc No:595R07L00
---------------------------------	----------------------------------	---------	-------------------------

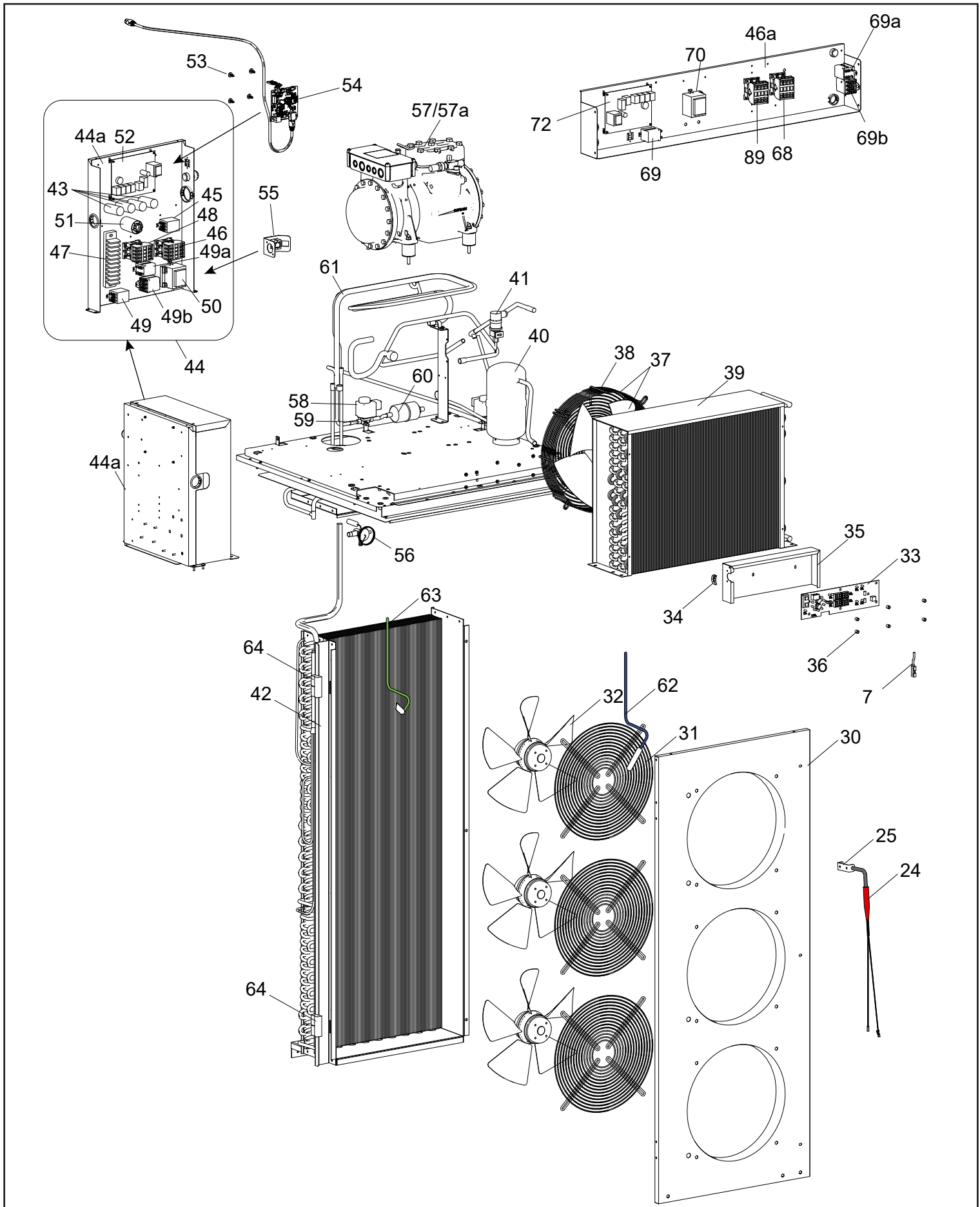

COOLING UNIT AND CONTROL PANEL

From Ser. Nr.
Up to Ser. Nr.

Ed. 01 2023-03
Ed. 01 2023-03

Page: 5 @

Doc No:595R07L00

POS	FACTORY CODE	S.P. CODE	DESCRIPTION	V	W&T	REF.	NOTES	S/N BREAK (YYYY/WK)
30	0502767002	092474	Fan evaporator carter		x			
31	0542R01100	093087	Motor fan grid		x			
32	0858760900	099646	Fan evaporator assembly	x				
33	0648R02M00	097726	User board	x				
34	0639R23600	097673	Grommet	x				
35	0504R37800	097702	User board protection		x			
36	0546R08D00	097674	Round spacer Ø 6,2 ; EX 9,0	x				
37	0856R25501	094829	Motor fan condenser ELCO 230-240V/50-60 HZ	x				
38	0514760800	090022	Protection fan condenser	x				
39	0830R12200	094853	Gas condenser	x				
40	0805725601	083468	Liquid receiver	x				
41	0646R20300	096201	Pressure switch for high pressure	x				
42	0830R02601	091695	Evaporator	x				
43	0648729500	090089	Capacitor 5 UF UL-CSA	x				
44	0855R0A601		Electric box assembly	x		a; c; d; e; h; i		
44	0855R0AR00		Electric box assembly	x		b; f; g	220-230V	
44a	0512776501	097707	Electric box	x				
45	0694701300	099146	Electric filter	x				
46	0640R00600	091706	Safety switch for compressor	x		a; c; d; e; h; i		
46	0640R01900	093194	Safety switch for compressor	x		b; f; g	220-230V	
47	0855R09T01	097721	Clamp with wiring	x				
48	0648807300	088477	Contactora 220-230 50 hz	x		a; c; d; e; h; i		
48	0648729200	099090	Contactora 220-230 50 hz	x		b; f; g	220-230V	
49	0648802701	056510	Relay Finder 24 V	x				
49a	0648703800	083215	Relay Finder 60.62.8.230	x				
49b	0648725400	088197	Relay RA	x				
50	0624711702	087662	Voltage adaptor 230/24 V	x				
51	0694700800	084987	Filter LC		x			
52	0648R04902	093125	Main board	x				
53	0546401600	095984	Main board spacer	x				
54	*	*	Lion board connectivity		x			
55	*	*	Connectivity bracket LAN cable		x			
56	0646754900	088347	Thermostatic valve/Expansion valve	x				
57	0684729800	099648	Compressor DORIN	x		a; d; h; i	50 Hz	
57	0684730801	099650	Compressor DORIN	x		b; c; e; f; g	60 Hz	
57a		093647	Compressor heating cable	x				
57a		095542	Suction tap	x				
57a		097632	Krivan	x		b; c; e; f; g	60 Hz	
58	0646749000	088351	Coil for solenoid valve	x				
59	0646723000	084085	Solenoid valve	x				
60	0805747600	087438	Filter DML052 S	x				
61	0515796100	097712	Pipe exchanger	x				
62	0646R07200	092177	Blu cell probe	x				
63	0646R08101	092187	Green evaporator probe	x				
64	0830764200	090040	Hinge for carter		x			

SPARE PARTS CODE - COOLING UNIT AND CONTROL PANEL

* On demand

Bold=last change

From Ser. Nr. Up to Ser. Nr.	Ed. 01 2023-03 Ed. 01 2023-03	Page: 6	Doc No:595R07L00
---------------------------------	----------------------------------	---------	-------------------------

Electrolux Professional SpA
Viale Treviso, 15
33170 Pordenone, ITALY
Fax (+39) 0434 380 201
<https://www.electroluxprofessional.com>
<https://webgate.electroluxprofessional.com>

Finanzen / Service
28307 Bremen
Thalendorststraße 15
Tel.+49 421 48557-0
Fax+49 421 488650
bremen@nordcap.de

Vertrieb Ost
12681 Berlin
Wolfener Straße 32/34, Haus K
Tel.+49 30 936684-0
Fax+49 30 936684-44
berlin@nordcap.de

Vertrieb West
40699 Erkrath
Max-Planck-Straße 30
Tel.+49 211 540054-0
Fax+49 211 540054-54
erkraht@nordcap.de

Vertrieb Nord
21079 Hamburg
Großmoorbogen 5
Tel.+49 40 766183-0
Fax+49 40 770799
hamburg@nordcap.de

Vertrieb Süd
55218 Ingelheim
Hermann-Bopp-Straße 4
Tel.+49 6132 7101-0
Fax+49 6132 7101-20
ingelheim@nordcap.de



www.nordcap.de