

Ersatzteilliste-Explosionszeichnung

Schnellkühler / Schockfroster SF 100/70-LW CRI O CHILL



**BLAST CHILLER- FREEZER
ABBATTITORI CONGELATORI**

SKCH 10GN 2_1

Type Reference	Ref	Page	Description	note
SKCH70B	a	3_4_5_7	BCF 70KG 380V BUILT IN 50 HZ	EU
SKCH70R	b	3_4_6_7	BCF 70KG 380V REMOTO 50/60HZ	EU
SKCHU70B	c	3_4_5_7	BCF 70KG 208V BUILT IN 60 HZ	USA

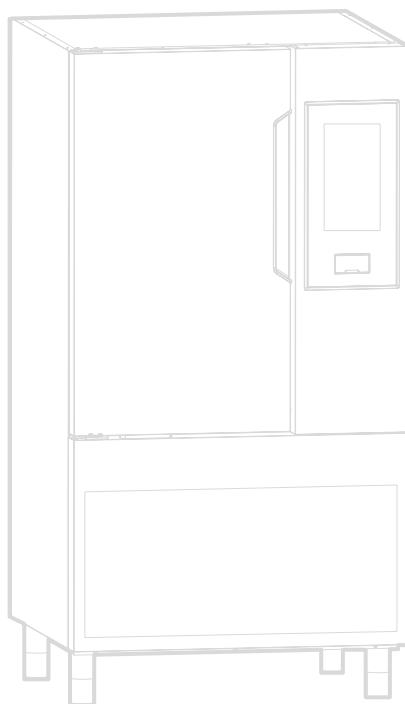

Index

	Page
Descriptions type ref/Descrizione el Type refence	2
Exploded view internal components/ Vista esplosa componenti interni	3
Exploded view Doors/ Vista esplosa porte	4
Exploded view cooling unit/ Vista esplosa gruppo refrigerante	5
Exploded view cooling unit remote/ Vista esplosa gruppo refrigerante remoto	6
Control panel/pannello comandi	7
Spare part list/Lista ricambi	8 to 11
Maintenance kit/Kit di manutenzione	11

...Bold= last change/Grassetto =ultima modifica

Rev. 7

How to put in relation the “Type Ref.” reported on the data plate with the “Type reference” reported on the front page of the Spare Part Catalogue:

The “Type Ref.” represents a group of models/brands all with similar technical features, hence possible to be reported under the same scheme in terms of exploded views.

Electrolux

SKCH

- B= UNIT ON BOARD CONDENSING UNIT
- R= REMOTE CONDENSING UNIT
- 30 = range 30 kg
- 50 = range 50 kg
- 70 = range 70 kg
- 100 = range 100 kg
- 150 = range 150 kg
- 200 =range 200 kg
- SKCH = SKYLINE CHILLER\FREEZER (EUROPA\SAUDI ARABIA\KOREA)
- SKCHU = SKYLINE CHILLER\FREEZER (NORD AMERICA)

ES: **SKCH30B** = range 30 kg gn 1\1 with cooling unit (europa etc.)
SKCH30R = range 30 kg gn 1\1 without cooling unit (remote) (europa etc.)
SKCHU30B = range 30 kg gn 1\1 with cooling unit (nord America)
SKCHU30R = range 30 kg gn 1\1 without cooling unit (remote) (nord America)

Find below an identification example: SKCH30B

F.Mod. PNC 9VTX.....	Comm.Model Ser.Nr.....	Type Ref. SKCH30B	2019
W.Tot. kW	Volt.....	Hz.....	Cyclopentane Total Current A
Evaporation Heater El. kW	Class x	GWP	CO2-eq t
Lighting W	Cap.	Refrigerant	Kg
Defrost Power kW	Heating power kW		
NF nominal Charge			
Rated Pressure Mpa		CE	WEEE
IPX4			
Electrolux Professional SPA - Viale Treviso, 15 - 33170 Pordenone (Italy)			

For the right spare code identification follow the steps:

- 1.Type in the website the PNC reported on the data plate.
- 2.The website will automatically display this spare part catalogue.
- 3.The spare part code at this point is referenced through the “Type reference” as from the front page by the relevant “Ref”.

Come mettere in relazione il “Type Ref.” Riportato sulla targhetta caratteristica con il “Type reference” riportato sul frontespizio del catalogo ricambi:

Il “Type Ref.” Rappresenta un gruppo di modelli/marchi con simili caratteristiche tecniche, ossia possibili da rappresentare con il medesimo schema in termini di vista esplosa.

Electrolux

SKCH

- B= UNITA' CON GRUPPO
- R= UNITA' PREDISPOSTA REMOTA
- 30 = MODELLO 30 kg
- 50 = MODELLO 50 kg
- 70 = MODELLO 70 kg
- 100 = MODELLO 100 kg
- 150 = MODELLO 150 kg
- 200 = MODELLO 200 kg
- SKCH = SKYLINE CHILLER\FREEZER (EUROPA\SAUDI ARABIA\KOREA)
- SKCHU = SKYLINE CHILLER\FREEZER (NORD AMERICA)

ES: **SKCH30B** = range 30 kg gn 1\1 con gruppo (europa etc.)
SKCH30R = range 30 kg gn 1\1 predisposto remoto (europa etc.)
SKCHU30B = range 30 kg gn 1\1 con gruppo (nord America)
SKCHU30R = range 30 kg gn 1\1 predisposto remoto (remote) (nord America)

Qui di seguito un esempio di identificazione: SKCH30B

F.Mod. PNC 9VTX.....	Comm.Model Ser.Nr.....	Type Ref. SKCH30B	2019
W.Tot. kW	Volt.....	Hz.....	Cyclopentane Total Current A
Evaporation Heater El. kW	Class x	GWP	CO2-eq t
Lighting W	Cap.	Refrigerant	Kg
Defrost Power kW	Heating power kW		
NF nominal Charge			
Rated Pressure Mpa		CE	WEEE
IPX4			
Electrolux Professional SPA - Viale Treviso, 15 - 33170 Pordenone (Italy)			

Per identificare il corretto codice ricambio procedere con:

- 1.Digitare nel website il PNC riportato sulla targhetta caratteristica.
- 2.Il website mostrerà automaticamente questo catalogo ricambi.
- 3.A questo punto, il codice ricambio è identificabile attraverso il “Type reference” come indicato nel frontespizio sotto la relativa voce “Ref”.

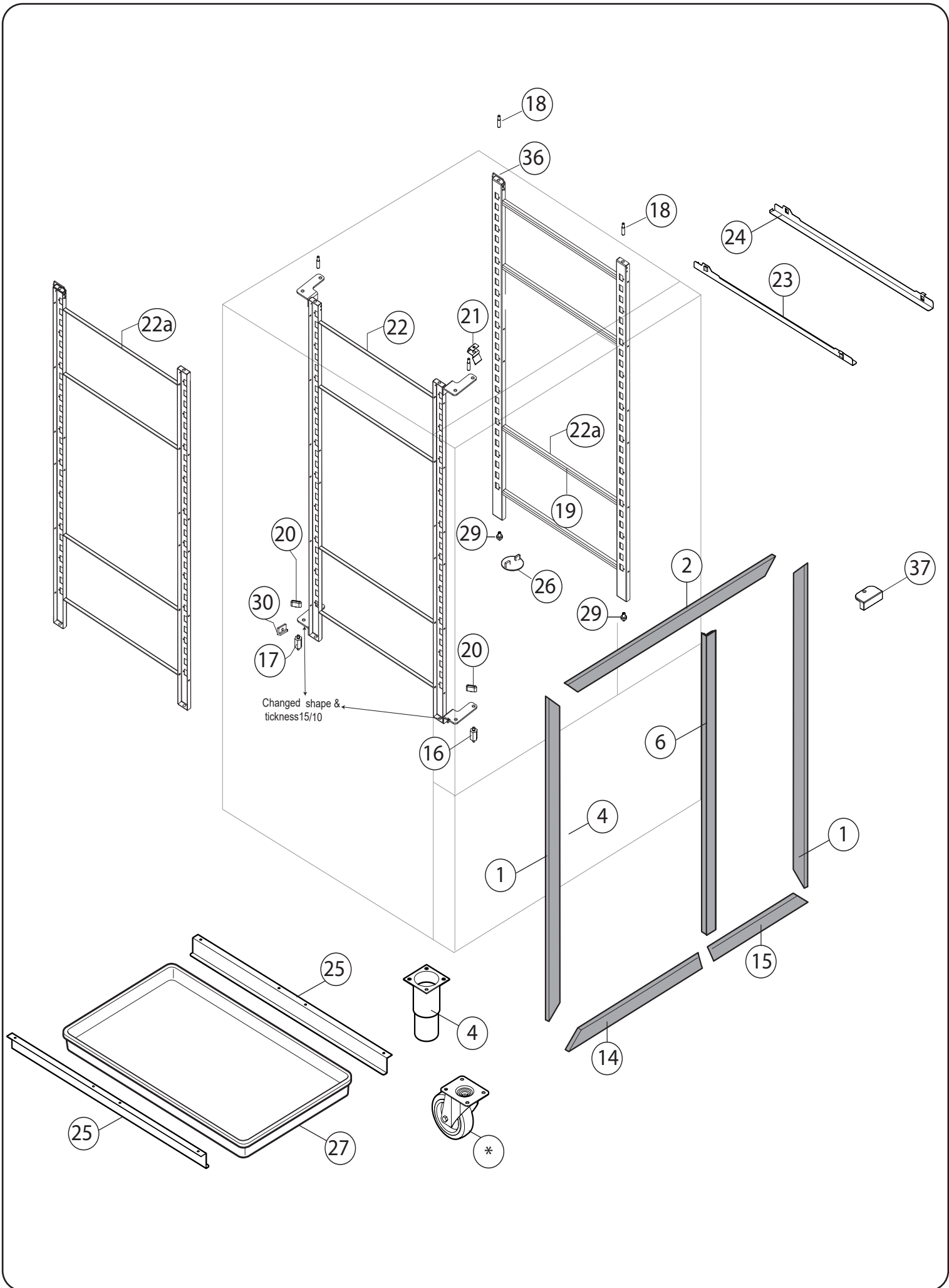

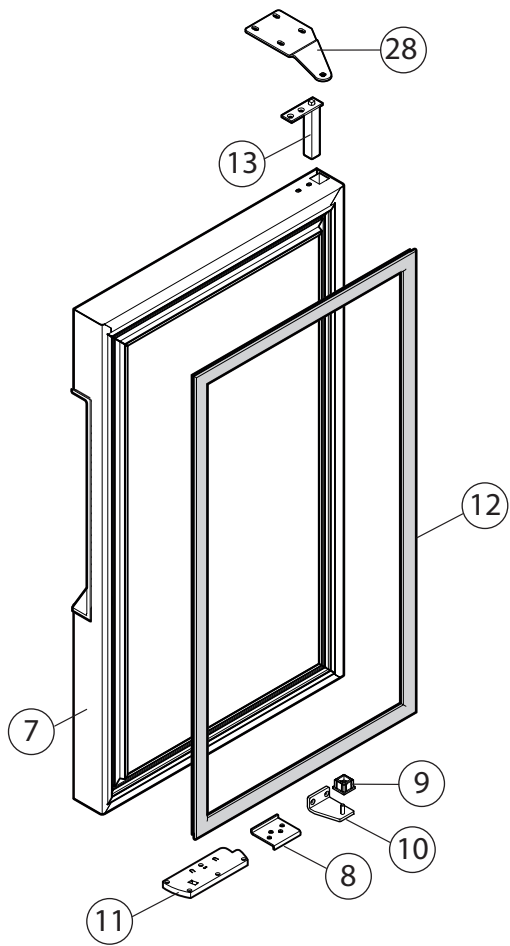

DOOR ELUX LEFT

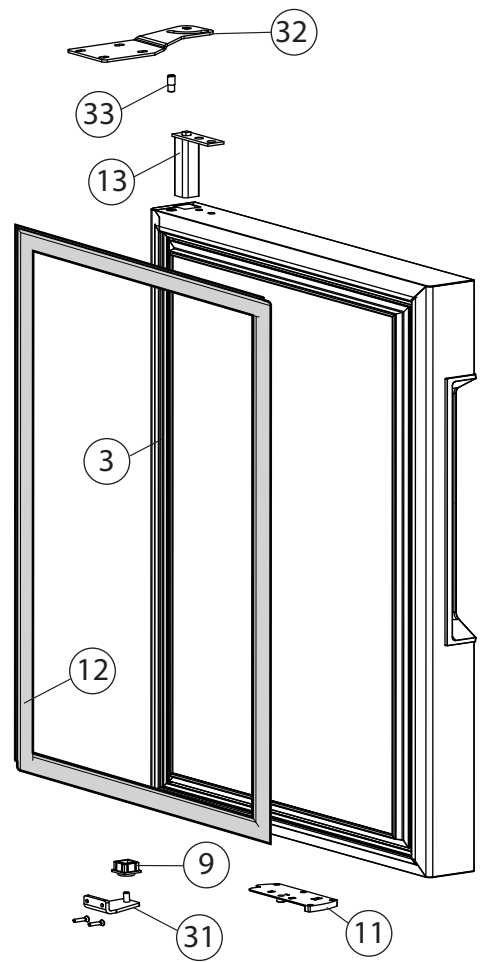

DOOR ELUX RIGHT

DOOR apx/zan LEFT

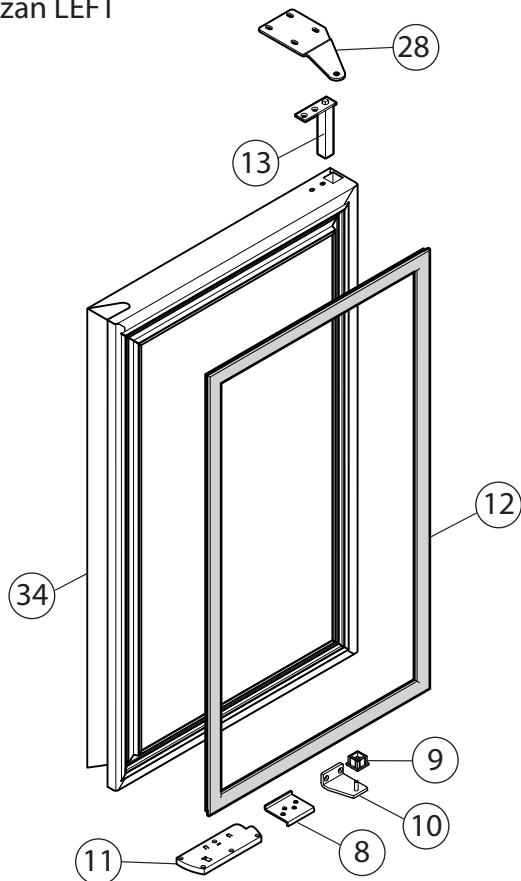

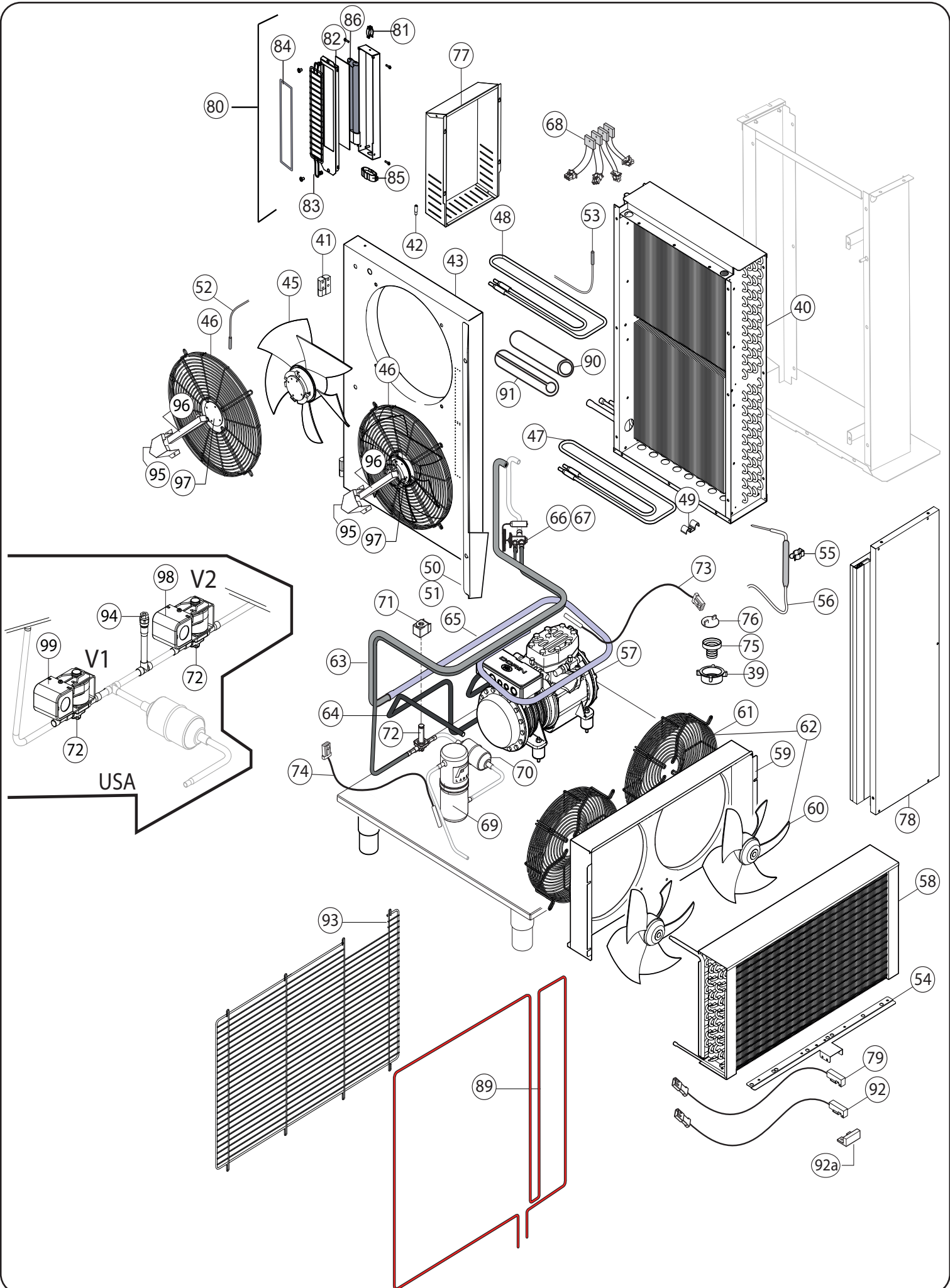

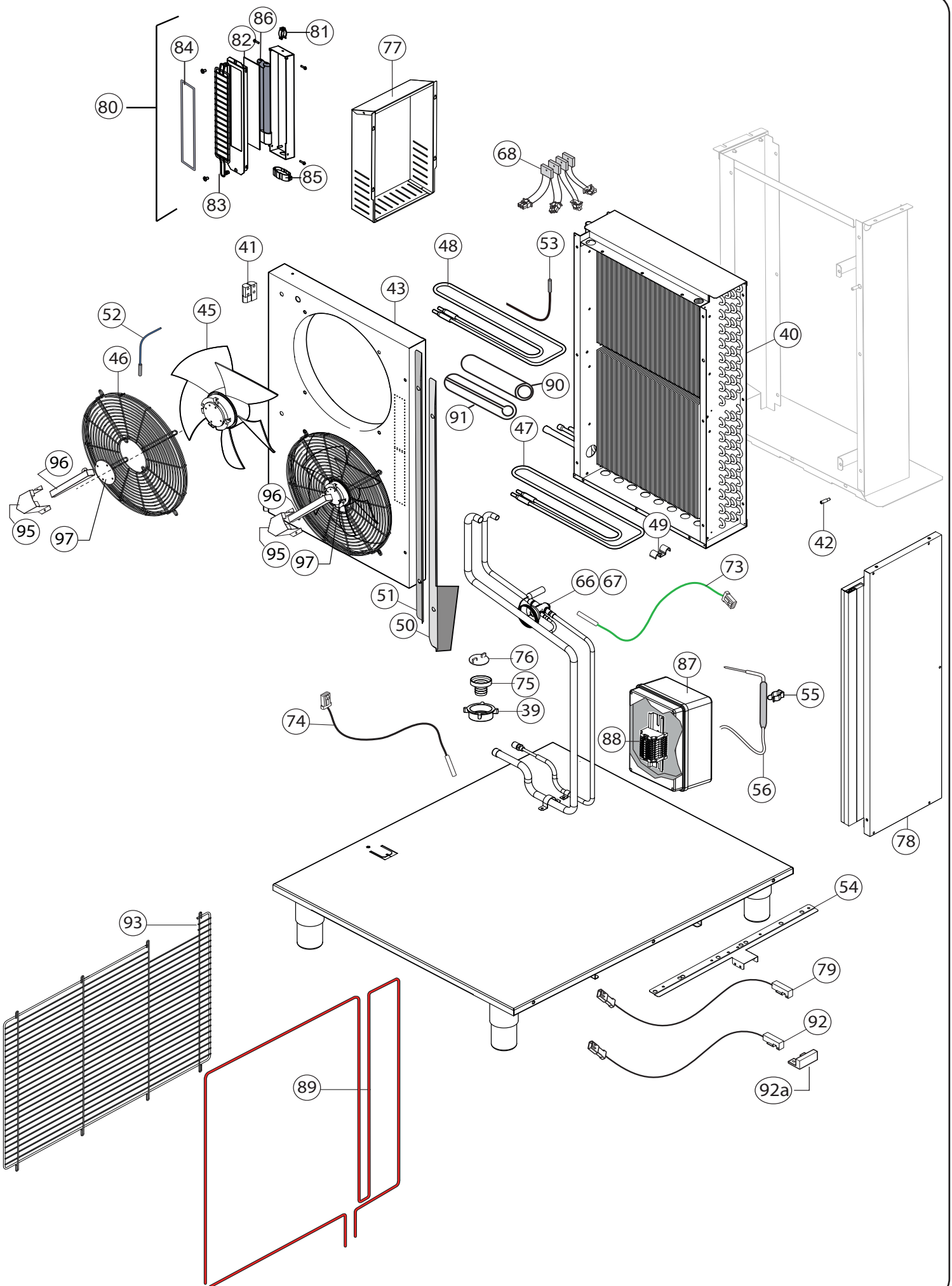

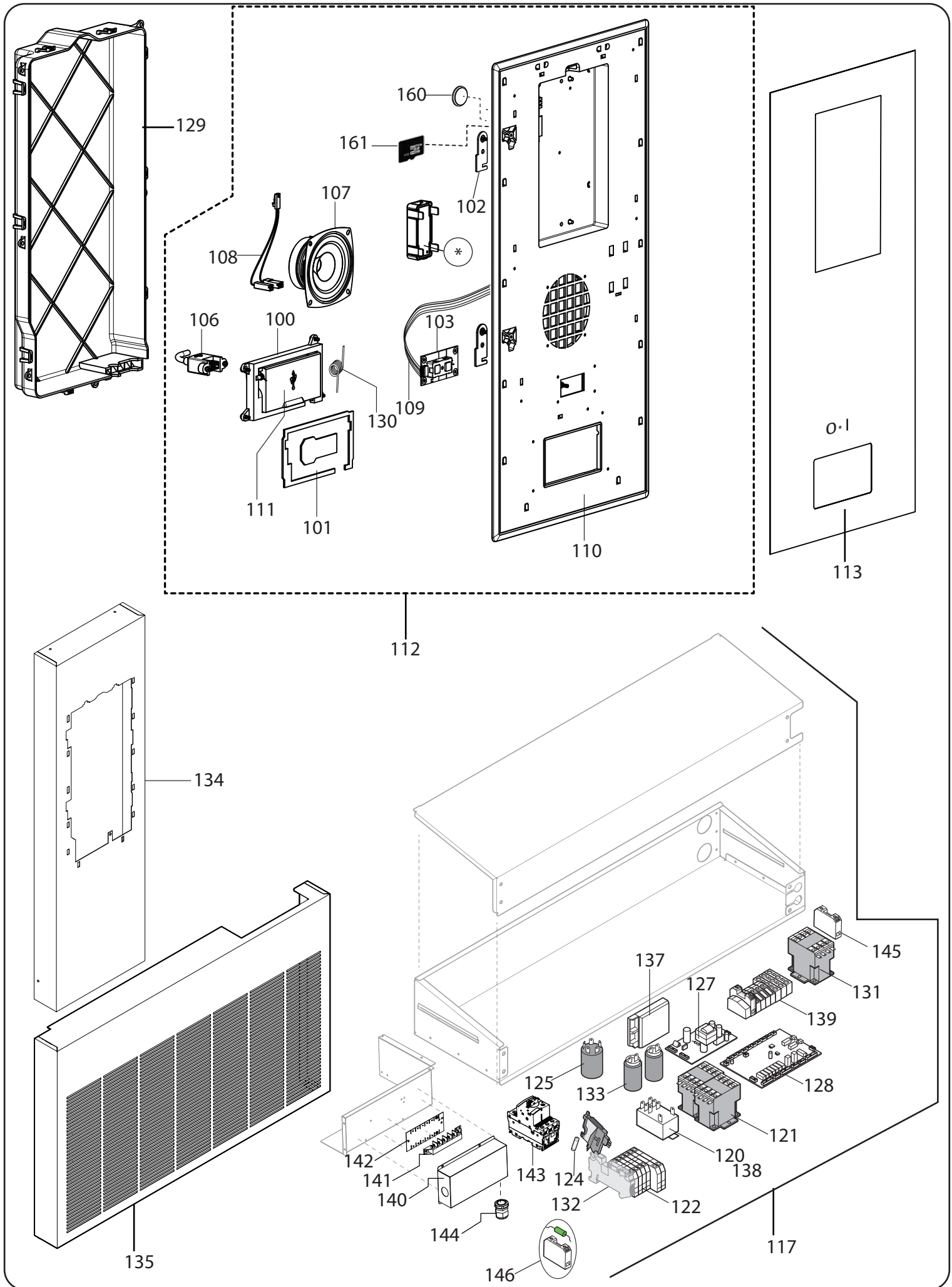

POS	Code	Factory code	Description	Descrizione	Ref/notes
1	095981	0543R17101	ASSEMBLY COVER WITH MAGNET - V	CORNICE VERTICALE (left and right)	up to Week 44 2019 - 901 mm
1	096437	0543R24401	ASSEMBLY COVER WITH MAGNET - V	CORNICE VERTICALE (left and right)	from Week 45 2019 - 902 mm
2	096066	0543R23700	ASSEMBLY COVER + MAGNET - H- UP	CORNICE ORIZZONTALE SUP.	up to Week 44 2019 - 1100 mm
2	096438	0543R24500	ASSEMBLY COVER + MAGNET - H- UP	CORNICE ORIZZONTALE SUP.	from Week 45 2019 - 1101 mm
3	096099	0882R18800	DOOR RIGHT ELUX BCF70 ASS.Y	ASS. PORTA DX	ELUX RIGHT
*	096099	0882R18801	DOOR MOD RIGHT ELUX	MODULO PORTA DESTRA	ELUX RIGHT
*	on demand	0882R43901	DOOR MOD RIGHT ZAN/APX/TO BRA.	MODULO PORTA DESTRA	ZAN/APX/TO BRAND RIGHT
*	096096	0882R18704	DOOR MOD LEFT ELUX	MODULO PORTA SINISTRA	ELUX LEFT
*	096100	0882R43801	DOOR MOD LEFT ZAN/APX/TO BRAND	MODULO PORTA SINISTRA	ZAN/APX/TO BRAND LEFT
4	048579	0855631900	FOOT EU	ASS.PIEDE LG.153	a,b
4	096236	0833R48700	FOOT USA	ASS.PIEDE LG.153 usa	c
5	096243	0883R09200	ASSEMBLY FEET + SCREWS H153 N°4	ASSIEME PIEDI N°4 H153 + VITI	c
6	096395	0543R18700	ASSEMBLY COVER WITH MAGNET - V P	CORNICE VERTICALE PANNELLO SCH.	up to Week 44 2019 - 899 mm
6	096442	0543R24900	ASSEMBLY COVER WITH MAGNET - V P	CORNICE VERTICALE PANNELLO SCH.	from Week 45 2019 - 900 mm
7	096096	0882R18703	DOOR LEFT ELUX BCF70 ASSEMBLY	ASS. PORTA SX	a,b,c ELUX LEFT
8	092917	0510789200	LOWER DOOR SUPPORT	PIASTRINA INF.PORTA	
9	0A8856	0544705201	LOWER DOOR BUSH	BOCCOLA X 1/2P INFERIORE	
10	095914	0832R23402	LEFT LOWER HINGE	CERNIERA INFERIORE SX	
11	099909	0835R03800	PLATE DOOR OPEN	ASS. DISP. BLOCCO PORTA APERTA	
12	095987	0548R13500	DOOR MAGNETIC GASKET BCF70	GUARNIZIONE PORTA	
13	083876	0835714501	UPPER HINGE DOOR	CERNIERA CON MOLLA PERNO RIB.	
14	096059	0543R21200	ASSEMBLY COVER+MAGNET.H. LOW L	CORNICE ORIZZONTALE INF. SX	up to Week 44 2019 - 760 mm
14	096440	0543R24700	ASSEMBLY COVER+MAGNET.H. LOW L	CORNICE ORIZZONTALE INF. SX	from Week 45 2019 - 760 mm
15	096060	0543R21300	ASSEMBLY COVER+MAGNET.H. LOW R	CORNICE ORIZZONTALE INF. DX	up to Week 44 2019 - 339 mm
15	096439	0543R24600	ASSEMBLY COVER+MAGNET.H. LOW R	CORNICE ORIZZONTALE INF. DX	from Week 45 2019 - 341 mm
16	093935	0514R13301	FRONT RACK SUPPORT	SUPPORTO GUIDE ANT. BCF	
17	093936	0514R13401	BACK RACK SUPPORT	SUPPORTO GUIDE POST. BCF LW	
18	089970	0518713900	PIN FOR RACK	PERNO PER CARTER M6 BCF	
19	on demand	0833R49800	RACK SUPPORT ASS. (RIGHT) 15/10	ASS. STRUTTURA DX 15/10	Replace code 096038 (10/10)- Upgrade sturdiness
20	093939	0530R04700	LOCK NUT FOR RACK	CHIAVETTA DI SERRAGGIO	
21	096450	0514R29400	SPRING FOR RACK	MOLLA BLOCCO CREMAGLIERE	
22	on demand	0833R49700	RACK SUPPORT ASS. (LEFT) 15/10 without slide only holes	ASS. STRUTTURA SX 15/10 senza guida di scorrimento solo fori	Replace code 096077 (10/10) Upgrade sturdiness
22a	096553	833R47501	GRID ASSEMBLY (left and right)	ASS. STRUTTURA DX & SX 15/10	reference TB VTX2020-04 and VTX2021-01
23	096545	505R08F00	LEFT GUIDE FOR RACK 15/10	GUIDA BCF SX 15/10	Replace code 093994 -(10/10) Upgrade sturdiness
24	096546	505R08G00	RIGHT GUIDE FOR RACK 15/10	GUIDA BCF DX 15/10	Replace code 093995 -(10/10) Upgrade sturdiness
25	089977	0510774302	BASIN GUIDE	GUIDA PER BACINELLA EST	
26	096325	0835r72302	DISCHARGE PLUG DEVICE	ASS. TAPPO SCARICO CELLA JJ	
27	080803	0242452410	BLACK CONDESATE BASIN	BACINELLA RACC.COND.NERO	
28	096055	0505R29700	UPPER HINGE DOOR LEFT	CERNIERA SUP.X ABB. SX	
29	095977	0518R09300	LOWER PIN FOR BCF JJ SRUCTURE	PERNO INFERIORE STRUTTURA	
30	093938	0546R29300	RACK SUPPORT	APPOGGIO PER CREMAGLIERE	
31	096076	0832R23500	RIGHT LOWER HINGE BCF70 JJ	CERNIERA INFERIORE DX	
32	096039	0503R50301	RIGHT UPPER HINGE WITH STOP	CERNIERA SUPERIORE DX	
33	096056	0514R28000	STUD FOR DOOR STOP BCF JJ	PERNO PER FERMO PORTA SUP	
34	096100	0882R43801	DOOR SX ZAN/APX BCF70 JJ ASS.Y	ASS. PORTA SX APX/ZAN	APX/ZAN LEFT
35	096054	0505R29600	UPPER HINGE DOOR	CERNIERA SUP.X ABB. SX	APX/ZAN LEFT
36	095966	0514R28701	LOCKING SPRING BCF JJ	MOLLA FISSAGGIO CREMAGLIERA DX	
37	097535	0546R08B00	DOOR GASKET PROTECTION	PROTEZIONE GUARNIZIONE PORTA	

POS	Code	Factory code	Description	Descrizione	Ref/notes
39	094257	0546R26900	NUT 1'1/2	GHIERA 1'1/2	
40	095911	0830R13802	FINNED COIL EVAPORATOR BCF 70	EVAPORATORE	
41	095979	0530R08101	CARTER HINGE	CERNIERA CARTER VENTILATORI	
42	089970	0518713900	PIN FOR CARTER FAN	PERNO PER CARTER M6	
43	095949	0503R49403	EVAP. CONVEYOR BCF	CONVOGLIATORE EVAPORATORE	without predisp. for UV
43	096049	0504R02601	EVAP. CONVEYOR BCF70 UV LAMP	CONVOGLI. EVAPORATORE UV LAP	predisposed for uv lamp
43	096451	0504R18000	EVAP. CONVEYOR BCF70 USA	CONVOGLI. EVAPORATORE USA	c
45	096011	0682R11801	CAVITY FAN	VENTILATORE CELLA	a,b
45	096333	0682R13000	CAVITY FAN UL/IEC USA	VENTILATORE CELLA USA	c
46	095963	0514R26701	GRID DIAM.380 PAINT BLACK	GRIGLIA VENTILATORE CELLA NERO	a,b
46	096424	0514R29901	GRID DIAM.380 AISI 304	GRIGLIA VENTILATORE CELLA AISI 304	c
47	095921	0856R31103	HEATING ELEMENT DOWN 800 W	RESISTENZA SBRINAM. BASSA 230 V	a,b
47	096386	0856R36700	HEATING ELEMENT DOWN 800 W 208V	RESISTENZA SBRINAM. BASSA 208 V	c
48	095922	0856R31303	HEATING ELEMENT UP 800 W 230V	RESIST. SBRINAMENTO ALTA 230 V	a,b
48	096387	0856R36800	HEATING ELEMENT UP 800 W 208V	RESISTENZA SBRINAMENTO ALTA 208 V	c
49	048429	0506675402	BRACKET FOR HEATING ELEMENT	SQUADR.FISS.RESIST.VASCA	
50	095956	0504R00500	FRONT DEFLECTOR	DEFLETTORE ANT	
51	095957	0504R00600	REAR DEFLECTOR	DEFLETTORE POST	
52	096073	0646R21100	CELL PROBE BLUE long	SONDA 6X20 BLU 'CELL' lunga	a 50 Hz,b
52	096073	0646R21100	CELL PROBE BLUE long	SONDA 6X20 BLU 'CELL' lunga	a 60 Hz from 2022/29
52	096335	0646R22400	CELL PROBE BLUE short	SONDA 6X20 BLU 'CELL' corta	c
52	096335	0646R22400	CELL PROBE BLUE short	SONDA 6X20 BLU 'CELL' corta	a 60 HZ up to 2022/28
53	096074	0646R21200	EVAPORATOR PROBE GREY long	SONDA 6X40 GRIGIA 'EVAP' lunga	a,b
53	096336	0646R22500	EVAPORATOR PROBE GREY short	SONDA 6X40 GRIGIA 'EVAP' corta	c
54	097040	0505R08P00	SUPPORT FOR MICROINTERR.	STAFFA PER MICRO PORTA	50 Hz - Up to 2022/28
54	097533	0505R08P01	SUPPORT FOR MICROINTERR.	STAFFA PER MICRO PORTA	50 Hz - From 2022/29
54	096041	0503R73502	SUPPORT FOR MICROINTERR.	STAFFA PER MICRO PORTA	60 Hz - Up to 2022/28
54	097528	0503R73503	SUPPORT FOR MICROINTERR.	STAFFA PER MICRO PORTA	60 Hz - From 2022/29
55	091800	0639730101	FOOD PROBE HOOK	GANCIO IN AISI 304	
56	096072	0646R20700	FOOD PROBE	SPILLONE CONICO 3 PUNTI SILIC.	a,b
56	096338	0646R22801	FOOD PROBE UL/IEC	SPILLONE CONICO 3 PUNTI SILIC.	c
57	089989	0684728100	COMPRES. DORIN H390CS 400V 50HZ	COMPRESSORE H390CS 400V 50HZ	a
57	096452	0684R14000	COMPRESSOR DORIN H390CS 208/3/60	COMPRESSORE H390CS 208/3/60	c
58	096017	0830R13202	FINNED COIL CONDENSER	CONDENSATORE ARIA	a,c
59	095947	0503R49103	CONVEYOR AIR CONDENSER	CONVOGLIATORE CONDENS. 50KG	a,c
60	095896	0682R11900	FAN CONDENSER	VENTILATORE CONDENSATORE	a
60	096379	0856R38000	FAN CONDENSER 200V/50/60HZ	VENTILATORE CONDENS. 200V/50/60HZ	c
61	090022	0514760800	GRID FAN CONDENSER	GRIGLIA VENTILATORE CONDENSAT.	a,c
62	095925	0856R32300	ASS. FAN + GRID	ASS.VENTILATORE + GRIGLIA	a
63	on demand	*	WELDED EXCHANGER BCF	SCAMBIATORE SALDATO	a,c
64	on demand	*	PIPE COMPRES.-CONDENSER BCF	TUBO DA COMPRES. CONDENS.RE	a,c
65	on demand	*	PIPE COMPRESSOR SUCTION BCF	TUBO DA EVAP. A COMPRESSORE	a,c
66	096008	0646R20000	EXPANSION VALVE -40/-56 ORIF.9	VALVOLA TERMOSTATICA	R448/R452/R404a
67	095939	011008R010	INSULATION FOR THERMOS. VALVE	ISOLAMENTO VALVOLA TERMOSTAT.	Diam. 15
67	095938	0110067003	INSULATION FOR THERMOS. VALVE	ISOLAMENTO VALVOLA TERMOSTAT.	Diam. 35
68	096340	0652R02800	SAFETY THERMOFUSE 93°C	TERMOFUSIBILE 93°C BCF JJ UL	
69	087758	0805749401	TANIC RECEIVER 0.88L	RICEVITORE DI LIQ. A SALD. 0,88 L	a,c
70	087438	0805747600	DEHIDRATOR FILTER	FILTRO DCL083S 10MM	a,c
71	088351	0646749000	BOB.CLIP 10W EVR6 220-230/50-60	BOBINA VALVOLA SOLENOIDE	a
72	084085	0646723000	BODY SOLENOID VALVE	CORPO VALV. EVR 6	a,c
73	096005	0646R19201	SUCTION PROBE "GREEN"	SONDA ASPIRAZIONE VERDE	a,b

POS	Code	Factory code	Description	Descrizione	Ref/notes
73	096339	0646R22600	SUCTION PROBE "GREEN"	SONDA ASPIRAZIONE VERDE	c
74	096006	0646R19301	CONDENSER PROBE "BLACK"	SONDA CONDENSATORE NERA	
75	094256	0546R26200	RUBBER SUPPORT	PORTAGOMMA	
76	096325	0835r72302	DISCHARGE PLUG DEVICE	ASS. TAPPO SCARICO CELLA JJ	
77	095961	0505R29301	BACK SPACER PROTECTION eu	DISTANZIALE /COPERTURA POST.	a,b
77	096240	0505R30900	BACK SPACER PROTECTION usa	DISTANZIALE /COPERTURA POST.	c
78	095919	0835R61404	EVAPORATOR FOAMED PANEL BCF70	PANNELLO SCHIUMATO DI COPERT.	
79	096002	0640R04101	DOOR MICROSWITCH	MICRO PORTA	
80	096075	0832R09501	ASS. UV LAMP	ASSIME LAMPADA	
80	097537	0832R28500	ASS. UV LAMP	ASSIEME LAMPADA	c with UV lamp
81	084384	0624705200	PLASTIC SPRING	MOLLE PER LAMPADA	
82	093097	0549R05400	GLASS UV	VETRO FRONTALE LAMPADA	
83	093945	0514R11900	PROTECTION	PROTEZIONE	
84	093946	0559R01800	FRONT GASKET	GUARNIZIONE LAMPADA	
85	093948	0665R01100	UV SUPPORT	SUPPORTO LAMPADA	
86	093949	0661R01100	UV LAMP	LAMPADA	
87	096068	0639R19700	GEWISS BOX REMOTE	SCATOLA GEWISS REMOTO	b
88	096071	0639R20000	REMOTE CLAMP CONNECTIONS R.	MORSETTIERA SCATOLA REMOTA	b
89	095992	0617R18501	HEAT. EL. CABLE BCF 70KG L=5200MM	CAVO RISCALDANTE L=5200MM	230V a,b
89	096384	0617R18800	HEAT. EL. CABLE BCF 70KG L=5200MM	CAVO RISCALDANTE L=5200MM 10W/M	208V c
90	095983	0544R07600	PIPE PVC	TUBO PVC RIGIDO IRLHF Ø40	
91	095989	0569R10000	COIBENTATION PIPES	TUBO ANTICOND. GREY DIAM.16-36	
92	095929	0646R20601	MAGNETIC SENSOR UV LAMP	SENSORE MAGNETICO LAMPADA UV	a UV lamp
92a	087533	0640712000	MAGNET STEM	MAGNETE STEM	a,c UV lamp from 2022/29
93	095965	0514R26901	REAR PROTECTIVE GRID BCF70 JJ	GRIGLIA POSTERIORE	a,b
93	096426	0514R30101	REAR PROTECTIVE GRID BCF70 JJ	GRIGLIA POSTERIORE usa	c
94	099869	0646765300	SAFETY BLOW FUSE HP PRESSURE	TAPPO FUSIBILE . FPA-283 UL 1/8'	
95	096447	0504R00900	EXTERNAL PROTECTION FAN CABLE	PROTEZIONE ESTERNA CAVO VENT.	
96	096448	0504R01001	INTERNAL PROTECTION FAN CABLE	PROTEZIONE INTERNA CAVO VENT.	
97	096449	0504R01100	FAN COVER PROTECTION	PROTEZIONE PER VENTILATORE	
98	096241	0830R02A01	SOLENOID VALVE COIL V2 208V usa	BOBINA VALVOLA SOLENOIDE V2	c (red connector)
99	096423	0856R38101	SOLENOID VALVE COIL V1 208V usa	BOBINA VALVOLA SOLENOIDE V1	c (white connector)
100	0CK030	0546400U01	DRAWER USB SUPPORT	CKM SEDE USB	
101	0CK031	0543401P02	GASKET DRAWER USB SUPPORT	GUARNIZIONE SEDE USB	
102	0CK432	0506405M00	PANEL HOOK	GANCIO PANNELLO	
103	0CK033	0675401G00	ON/OFF BOARD	SCHEDA ON/OFF	
106	0CK037	0638404D00	WIRING USB	CAVO USB	
107	0CK039	0655400000	SPEAKER VISATON	ALTOPARLANTE	
108	0CK330	0675401L00	WIRING SPEAKER	CAVETTO CONNESSIONE SPEAKER	
109	0CK045	0675401Q00	WIRING ON/OFF BOARD	CAVETTO ON-OFF TOUCH	
110	0CK040	0543401N01	PLASTIC FRAME TOUCH	PANNELLO IN PLASTICA	
111	0CK041	0546400V01	USB COVER	SPORTELLINO USB ELUX	
112	0CK685	083040PL01	ASS. TOUCH UI ELUX PREDISPOSED WITH ETHERNET DIRECT CONNECTION	PANNELLO COMPLETO UI PREDISPOSTO CON CONNESSIONE ETHERNET	
113	095934	0755R13902	ADHESIVE DECOR A ELUX	MEMBRANA ADESIVE ELUX	order with n°11
113	095936	0755R16202	ADHESIVE DECOR A TOUCH APX	MEMBRANA ADESIVE APX	order with n°11
113	095935	0755R16103	ADHESIVE DECOR A TOUCH ZAN	MEMBRANA ADESIVEZAN	order with n°11
113	096058	0541401V02	ADHESIVE DECOR A TO BRAND	MEMBRANA ADESIVE TO BRAND	order with n°11
117	096084	0882R86301	ELECTRICAL BOX COMPLETE UV	SCATOLA ELETTRICA COMPLETA	a for uv lamp
117	096080	0882R19106	ELECTRICAL BOX COMPLETE	SCATOLA ELETTRICA COMPLETA	a without uv lamp
117	096082	0882R72502	ELECTRICAL BOX COMPLETE REM	SCATOLA ELETTRICA COMPLETA REM	b

POS	Code	Factory code	Description	Descrizione	Ref/notes
117	096576	0883R09402	ELECTRICAL BOX COMPLETE	SCATOLA ELETTRICA COMPLETA	c
117	097539	0883R66301	ELECTRICAL BOX COMPLETE	SCATOLA ELETTRICA COMPLETA	c for UV lamp from 2022/29
120	093848	0648R06300	RELAY 66.82.8.230.0001	RELE' FINDER	
121	088477	0648807300	CONTACTOR K3-10N 230V 50/60HZ	CONTATTORE K3-10N 230V 50/60HZ	a,b
122	096000	0639R18401	MAIN TERMINAL BLOCK	BLOCCHETTI DI CONNESSIONE ELET.	a
122	096070	0639R19900	MAIN TERMINAL BLOCK	BLOCCHETTI DI CONNESSIONE ELET.	b
122	096453	0639R22800	MAIN TERMINAL BLOCK	BLOCCHETTI DI CONNESSIONE ELET.	c
124	095933	0652R02400	GLASS FUSE 10A T 5X20	FUSIBILE IN VETRO 10A T 5X20	
125	059078	0694502400	FILTRO LC 411524410D	FILTRO LC	for uv lamp
125	084987	0694700800	RFI FILTER 411.5.14.41.0 (TIPO L-C)	FILTRO ANTIDISTURBO	without uv lamp
127	095639	0648R10000	POWER SUPPLY 12V 30W	SCHEDA DI POTENZA 12V 30W	a,b
127	096342	0648R11400	POWER SUPPLY 12V/100W UL	SCHEDA DI POTENZA 12V/100W UL	c
128	096010	0648R08602	ACU PETRA BCF	SCHEDA PRINCIPALE PETRA	Up to 2020/20 canceled
128	096557	0648R10900	ACU PETRA BCF - BITRON	SCHEDA PRINCIPALE PETRA-BITRON	From 2020/21
129	0CK161	0541401D01	PROTECTION COMAND PANEL	PROTEZIONE PANNELLO COMANDI	
130	0CK032	0514405001	SPRING DOOR USB	MOLLA SPORTELLINO USB	
131	088477	0648807300	CONTACTOR K3-10N 10N 230V 50/60HZ	CONTATTORE K3-10N 230V 50/60HZ	a
131	099090	0648729200	CONTACTOR K3-10N 208V 60HZ	CONTATTORE K3-10N 208V 60HZ	c
132	093564	0639732800	FUSE SUPPORT	MORSETTO2 VIE X PORTAFUSIBILE	
133	090089	0648729500	FAN CAPACITOR 5 mF	CONDENS.B 5MFPER VENT. COND.	a
133	099129	0648729400	FAN CAPACITOR 4 mF	CONDENS.B 5MFPER VENT. COND.	c
134	095951	0503R62804	CONTROL PANEL BCF70	PANNELLO DI CONTROLLO SS	
135	095952	0503R65403	CONDENSER PANEL BCF70 ELUX	PANNELLO CONDENSATORE	ELUX
135	096050	0504R02700	CONDENSER PANEL BCF70 OTHER	PANNELLO CONDENSATORE	ALL
137	093950	0624R01600	POWER VOLTAGE ADAPTOR UV BULB	ALIMENTATORE UV LAMPADA	for uv lamp
137	097536	0624R00J00	POWER VOLTAGE ADAPTOR UV BULB	ALIMENTATORE UV LAMPADA	c for UV lamp
138	006610	0648806900	RELE'62.838.230.0009+ATT.BARRA	RELE' +ATT.BARRABARRA DIN OPP	b
139	095999	0639R18100	CLAMP POWER SIGNALS	MORSETTIERA POTENZA/SEGNALE	a
139	096069	0639R19800	CLAMP POWER SIGNALS	MORSETTIERA POTENZA/SEGNALE	b
139	096388	0639R22600	CLAMP POWER SIGNALS	MORSETTIERA POTENZA/SEGNALE	c
140	096443	0505R31400	COVER CONNECTION POWER SUPP.	COPERTURA MORSET. ANTERIORE	c
141	088165	0639726600	EXT. CLAMP POWER SIGNALS	MORSETTIERA FV122 B UL-CSA	c
142	097526	0598610500	TERMINAL BLOCK PLATE	TARGHETTA MORSETTIERA 6 POLI	c
143	096322	0648R11500	SWICTH PROTECTION (20-25A)	SALVAMOTORE (20-25A)	c
144	on demand	0544802300	CABLE STOPPER	PRESSACAVO CON CONTRODADO	c
145	091725	0640R01000	AUXILIARY CONTACTOR	CONTATTI AUSILIARI HK1-11	
146	097657	0835R33T00	KIT UV LAMP RECOVERY	KIT UV LAMP RECOVERY	UV lamp from 2022/29 - See Tech. Sheet VTX2022_02
160	on demand	*	BATTERY CR2032 V3 LITIO	BATTERIA MODELLO CR 2032 V3 LITIO	
161	0CK674	675403M00	MICRO SD 4G 4HC	MICRO SD 4G 4HC	
*	096171	0147300900	AMERICAN CANVAS TAPE M50XMM48	NASTRO TELA PLAST. M50XMM48	
*	095768	0147017034	PIVILENE INSULATION TAPE; 50X3SP	NASTRO 3M389 NERO (MM19 X 50MT)	

Electrolux Professional SpA
Viale Treviso, 15
33170 Pordenone, ITALY
Fax (+39) 0434 380 201
<https://www.electroluxprofessional.com>
<https://webgate.electroluxprofessional.com>

Finanzen / Service
28307 Bremen
Thalendorststraße 15
Tel.+49 421 48557-0
Fax+49 421 488650
bremen@nordcap.de

Vertrieb Ost
12681 Berlin
Wolfener Straße 32/34, Haus K
Tel.+49 30 936684-0
Fax+49 30 936684-44
berlin@nordcap.de

Vertrieb West
40699 Erkrath
Max-Planck-Straße 30
Tel.+49 211 540054-0
Fax+49 211 540054-54
erkrath@nordcap.de

Vertrieb Nord
21079 Hamburg
Großmoorbogen 5
Tel.+49 40 766183-0
Fax+49 40 770799
hamburg@nordcap.de

Vertrieb Süd
55218 Ingelheim
Hermann-Bopp-Straße 4
Tel.+49 6132 7101-0
Fax+49 6132 7101-20
ingelheim@nordcap.de



www.nordcap.de