

Installation

Electronic Modular Flaker **SP 255 L / W**

[Art. 413225000011] / [Art. 413225000021]



GENERAL INFORMATION AND INSTALLATION

A. INTRODUCTION

This manual provides the specifications and the step-by-step procedures for the installation, start-up and operation, maintenance and cleaning for the **SIMAG SPN 125-255-405-605 and SPN 1205** Modular Icemakers.

The Electronic Flakers and Superflakers are quality designed, engineered and manufactured. Their ice making systems are thoroughly tested providing the utmost in flexibility to fit the needs of a particular user.

NOTE. *To retain the safety and performance built into this icemaker, it is important that installation and maintenance be conducted in the manner outlined in this manual.*

Storage Bin

Since the SPN series Modular Flakers do not have their own attached ice storage bins, it is necessary to use an auxiliary bin as detailed here below:

R 100 or R 130 in combination with **SPN 125 and SPN 255.**

R 150 or R 190 with its companion **CBT 30 EFSD** Top Cover in combination with **SPN 125, SPN 255, SPN 405 and SPN 605.**

R 250 with its companion **CBT 42 EFSD** Top Cover in combination with **SPN 405/605.**

R 300 with its companion **CBT 48 FMCD** Top Cover in combination with **SPN 405/605.**

R 400 with its companion **CBT 52 FMCD** in combination with **SPN 405/605.**

B. UNPACKING AND INSPECTION

Icemaker

1. Call your authorized SIMAG Distributor or Dealer for proper installation.
2. Visually inspect the exterior of the packing and skid. Any severe damage noted should be reported to the delivering carrier and a concealed damage claim form filled in subject to inspection of the contents with the carrier's representative present.
3.
 - a) Cut and remove the plastic strip securing the carton box to the skid.
 - b) Cut open the top of the carton and remove the polystyrene protection sheet.
 - c) Pull out the polystyrene posts from the corners and then remove the carton.

4. On models SPN 125-255-405 and SPN 605 remove the top and front panel while on model SPN 1205 remove top and sides panels of the unit and inspect for any concealed damage. Notify carrier of your claim for the concealed damage as stated in step 2 above.

5. Remove all internal support packing and masking tape.

6. Check that refrigerant lines do not rub against or touch other lines or surfaces, and that the fan blades move freely.

7. Check that the compressor fits snugly onto all its mounting pads.

8. See data plate on the rear side of the unit and check that local main voltage corresponds with the voltage specified on it.

CAUTION. **Incorrect voltage supplied to the icemaker will void your parts replacement program.**

9. Remove the manufacturer's registration card from the inside of the User Manual and fill in all parts including: Model and Serial Number taken from the data plate. Forward the completed self-addressed registration card to SCOTSMAN ICE srl.

Storage bin (R Series)

1. Follow the steps 1, 2 and 3 above to unpack the storage bin.
2. Unloose the two bolts and remove the protection plate from the drain fitting on model R 250.
3. Carefully lay it down on its rear side and fit the four legs into their sockets.
4. Remove all internal support packing and masking tape as well as the plastic ice cube deflector which is not used with the SIMAG Modular Flakers.
5. Remove the manufacturer's registration card from the inside of the User Manual and fill in all parts including: Model and Serial Number taken from the data plate. Forward the completed self-addressed registration card to SCOTSMAN ICE Srl.

3. On **R Series Storage Bin** inspect its top mounting gasket which should be flat with no wrinkles, to provide a good sealing when the CBT Top Cover is installed on top of it.
4. Place the CBT Top Cover on top of Storage bin using care not to wrinkle or tear the gasket.
5. Lay out on the bin top the plan of the ice machine as it will be located on the bin and cut an opening in the bin top for the ice drop area; cover the edges of the opening with vinyl tape.
6. Install the gasket-on the bin top-around ice drop opening of the bin top; apply sealant along the inside of the gasket.
7. Position and install the four aluminium front to rear stiffeners (U shaped) paying attention to the guideline shown on the drawing.

CBT Top Covers

1. Follow the steps 1 and 2 above to unpack the top cover.
2. Cut open the carton box and pull out the CBT Top Cover.
3. On CBT 48/52 FMCD Top Covers, the ice drop area must be cutted on the plastic cover in the same position of the ice machine ice chute opening.

C. LOCATION AND LEVELLING

WARNING. This Modular Flaker and Superflaker is designed for indoor installation only. Extended periods of operation at temperature exceeding the following limitations will constitute misuse under the terms of the SCOTSMAN Manufacturer's Limited Warranty resulting in LOSS of warranty coverage.

1. Position the storage bin in the selected permanent location.
Criteria for selection of location include:
 - a) Minimum room temperature 10°C (50°F) and maximum room temperature 40°C (100°F).
 - b) Water inlet temperatures: minimum 5°C (40°F) and maximum 35°C (90°F).
 - c) Well ventilated location for air cooled models (clean the air cooled condenser at frequent intervals).
 - d) Service access: adequate space must be left for all service connections through the rear of the ice maker. A minimum clearance of 15 cm (6") must be left at the sides of the unit for routing cooling air drawn into and exhausted out of the compartment to maintain proper condensing operation of air cooled models.
2. Level the Storage Bin Assy in both the left to right and front to rear directions by means of the adjustable legs.

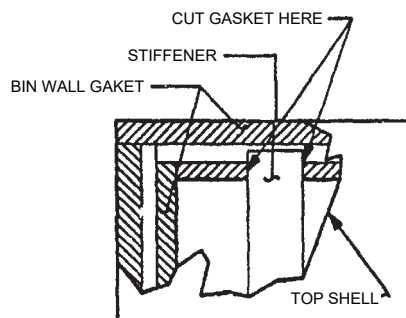

NOTE. Bin wall gasket must be cut to clear the stiffener ends as shown on drawing. Do not put any stiffeners crossing the ice drop opening.

9. Install the bin top in its position onto the bin top by:
 - place the rear side of top against rear edge of the bin
 - lower the front of the top onto the stiffeners
 - re-fit the screws previously removed as per step 5
10. Install the Modular Flaker or Superflaker onto the Top Cover of storage bin pay attention to match the ice chute with the Bin Top opening.

D. ELECTRICAL CONNECTIONS

See data plate for current requirements to determine wire size to be used for electrical connections. All SIMAG icemakers require a solid earth wire. All SIMAG ice machines are supplied from the factory completely pre-wired and require only electrical power connections to the wire cord provided at the rear of the unit.

Make sure that the ice machine is connected to its own circuit and individually fused (see data plate for fuse size).

The maximum allowable voltage variation should not exceed -10% and +10% of the data plate rating. Low voltage can cause faulty functioning and may be responsible for serious damage to the overload switch and motor windings.

NOTE. All external wiring should conform to national, state and local standards and regulations.

Check voltage on the line and the ice maker's data plate before connecting the unit.

E. WATER SUPPLY AND DRAIN CONNECTIONS

GENERAL

When choosing the water supply for the ice flaker consideration should be given to:

- a) Length of run
- b) Water clarity and purity
- c) Adequate water supply pressure

Since water is the most important single ingredient in producing ice you cannot emphasize too much the three items listed above.

Low water pressure, below 1 bar may cause malfunction of the ice maker unit.

Water containing excessive minerals will tend to produce scale build-up on the interior parts of the water system while too soft water (with too low contents of mineral salts), will produce a very hard flaker ice.

WATER SUPPLY

Connect the 3/4" GAS male of the water inlet fitting, using the food grade flexible hose supplied to the cold water supply line with regular plumbing fitting and a shut-off valve installed in an accessible position between the water supply line and the unit.

If water contains a high level of impurities, it is advisable to consider the installation of an appropriate water filter or conditioner.

WATER SUPPLY - WATER COOLED MODELS

The water cooled versions of SIMAG Ice Makers require two separate inlet water supplies, one for the water making the flaker ice and the other for the water cooled condenser.

Connect the 3/4" GAS male fitting of the water inlet, using the flexible hose supplied to the cold water supply line with regular plumbing fitting and a shut-off valve installed in an accessible position between the water supply line and the unit.

WATER DRAIN

The recommended drain tube is a plastic or flexible hose with 18 mm (3/4") I.D. which runs to an open trapped and vented drain. When the drain is a long run, allow 3 cm pitch per meter (1/4" pitch per foot).

Install a vertical open vent on drain line high point at the unit drain connection to ensure good draining.

The ideal drain receptacle is a trapped and vented floor drain.

WATER DRAIN - WATER COOLED MODELS

Connect the 3/4" GAS male fitting of the condenser water drain, utilizing a second flexible hose to the open trapped and vented drain.

This additional drain line must not interconnect to any other of the units drains.

NOTE. The water supply and the water drain must be installed to conform with the local code. In some case a licensed plumber and/or a plumbing permit is required.

F. FINAL CHECK LIST

1. Is the unit in a room where ambient temperatures are within a minimum of 10°C (50°F) even in winter months?
2. Is there at least a 15 cm (6") clearance around the unit for proper air circulation?
3. Is the unit level? (IMPORTANT)
4. Have all the electrical and plumbing connections been made, and is the water supply shut-off valve open?
5. Has the voltage been tested and checked against the data plate rating?
6. Has the water supply pressure been checked to ensure a water pressure of at least 1 bar (14 psi).
7. Have the bolts holding the compressor down been checked to ensure that the compressor is snugly fitted onto the mounting pads?
8. Check all refrigerant lines and conduit lines to guard against vibrations and possible failure.
9. Have the bin liner and cabinet been wiped clean?
10. Has the owner/user been given the User Manual and been instructed on the importance of periodic maintenance checks?
11. Has the Manufacturer's registration card been filled in properly? Check for correct model and serial number against the serial plate and mail the registration card to the factory.
12. Has the owner been given the name and the phone number of the authorized SIMAG Service Agency serving him?

G. INSTALLATION PRACTICE

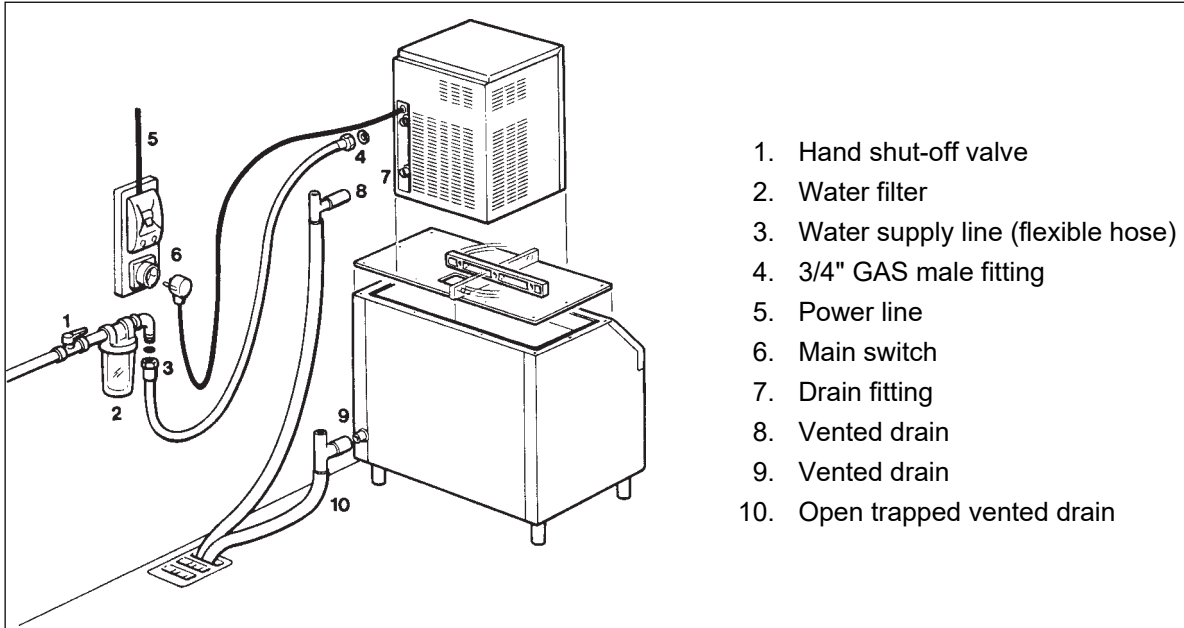

WARNING. This icemaker is not designed for outdoor installation and will not function in ambient temperatures below 10°C (50°F) or above 40°C (100°F). This icemaker will malfunction with water temperatures below 5 °C (40°F) or above 35 °C (90°F).

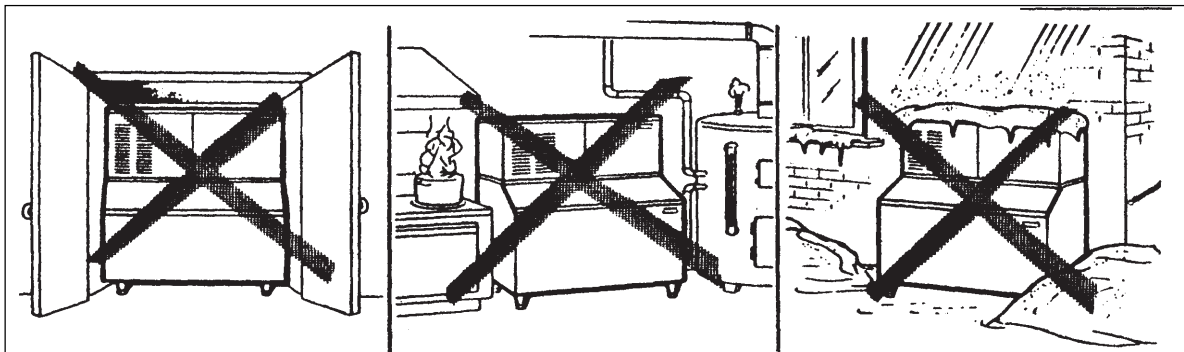

R134a-R404A-R452A Version

Electronic modular flakers and superflakers

Rev. 01/2020



Certified ISO 9001
TOTAL QUALITY

