

Ersatzteilliste-Explosionszeichnung

Gas-Fritteuse **GF9 / 1VB-23L-U1S-P-LS-AC**

[Art. 406392343]



SPARE PARTS CATALOGUE
CATALOGO PARTI DI RICAMBIO

FRIGGITRICI GAS ELETTRONICHE 23LT E 23+23LT 900XP
GAS ELECTRONIC FRYERS 23LT AND 23+23LT 900XP

PNC	DESCRIPTION	BRAND	REF
391333	23LT GAS FRYER PROGRAMMABLE	ELX	A
391334	23LT GAS FRYER-PROGR.+PUMP	ELX	B
391335	23LT GAS FRYER-PROG.+PUMP+LIFT.	ELX	C
391343	23L GAS FRYER-PROG.+PUMP+LIFT.+AUTO COOK	ELX	D
391375	23LT GAS FRYER PROGRAMMABLE-60HZ	ELX	E
391376	23LT GAS FRYER-PROGR.+PUMP-60HZ	ELX	F
391377	23LT GAS FRYER-PROG.+PUMP+LIFT.-60HZ	ELX	G
391379	23L GAS FRYER-PROG.+PUMP+LIFT.+AUTO COOK-60HZ	ELX	H
392333	23LT GAS FRYER PROGRAMMABLE	ZAN	I
392334	23LT GAS FRYER-PROGR.+PUMP	ZAN	J
392335	23LT GAS FRYER-PROG.+PUMP+LIFT.	ZAN	K
392343	23LT GAS FRYER-PROG.+PUMP+LIFT.+AUTO COOK	ZAN	L
393333	23LT GAS FRYER PROGRAMMABILE	OEM	M
393334	23LT GAS FRYER PROGRAMMABILE + PUMP	OEM	N
393335	23LT GAS FRYER PROGRAMMABILE + PUMP + LIFT	OEM	O
393343	23L GAS FRYER-PROG.+PUMP+LIFT.+AUTO COOK	OEM	P

Index

General componets / Componenti struttura	Page 2
Schede elettroniche / Electronic boards	Page 3
Imp. Olio e sollevatori / Oil circuit and lifters	Page 4
Gas components / Componenti Gas	Page 5
Nozzels / Ugelli	Page 6
Spare parts list / Liste ricambi	Page 7,8,9,10

Bold = Last change
Grassetto= Ultima modifica

Ed. page revision 2018 - 11

From Ser. Nr. 8041 Up to Ser. Nr.	Ed. document . N° 3 / 09-2018	Page 1	Doc. N° 59785VZ00
--------------------------------------	-------------------------------	--------	--------------------------

FRIGGITRICI GAS ELETTRICHE 23LT E 23+23LT 900XP
GAS ELECTRONIC FRYERS 23LT AND 23+23LT 900XP

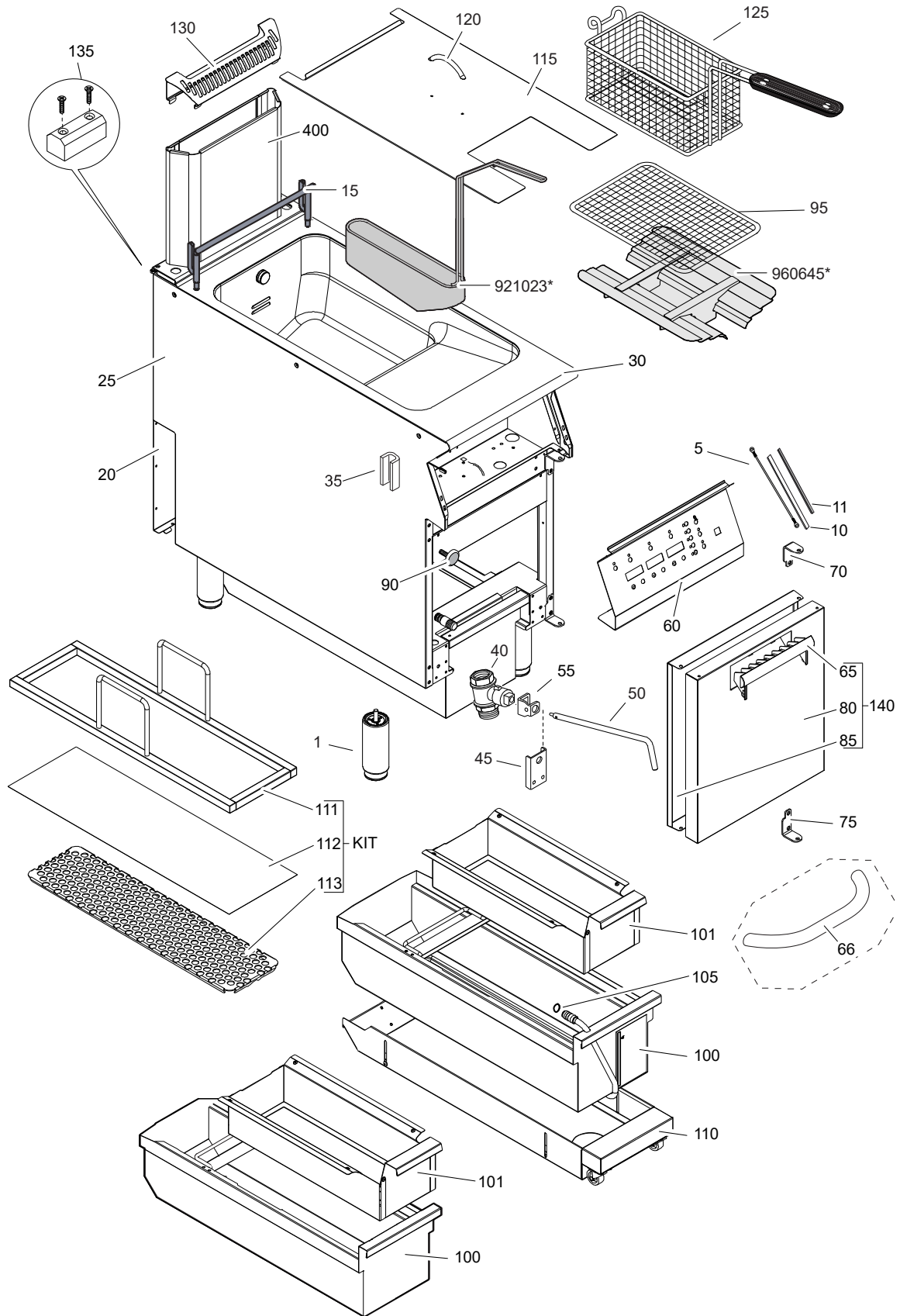

FRIGGITRICI GAS ELETTRONICHE 23LT E 23+23LT 900XP
 GAS ELECTRONIC FRYERS 23LT AND 23+23LT 900XP

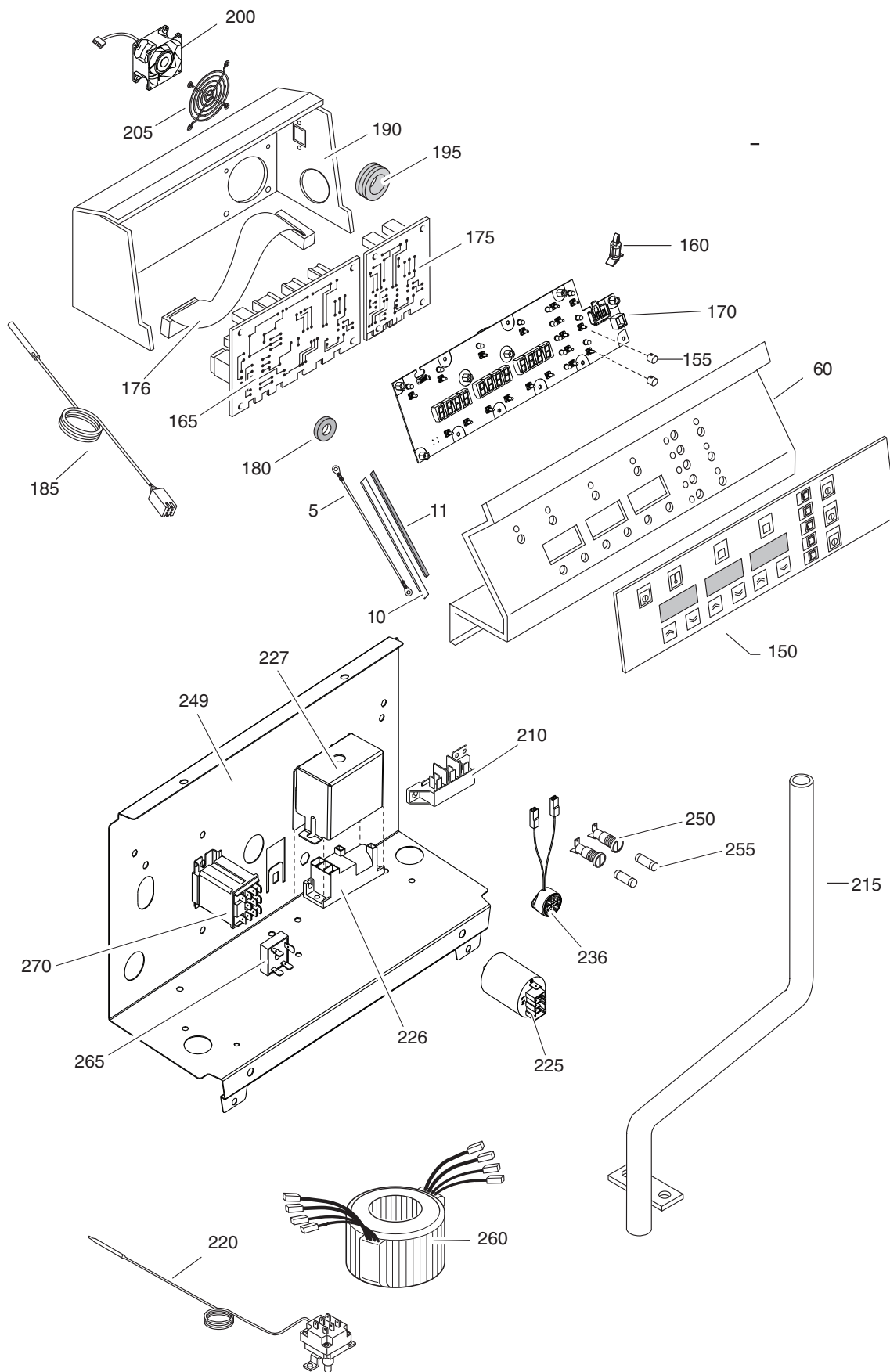

FRIGGITRICI GAS ELETTRONICHE 23LT E 23+23LT 900XP
 GAS ELECTRONIC FRYERS 23LT AND 23+23LT 900XP

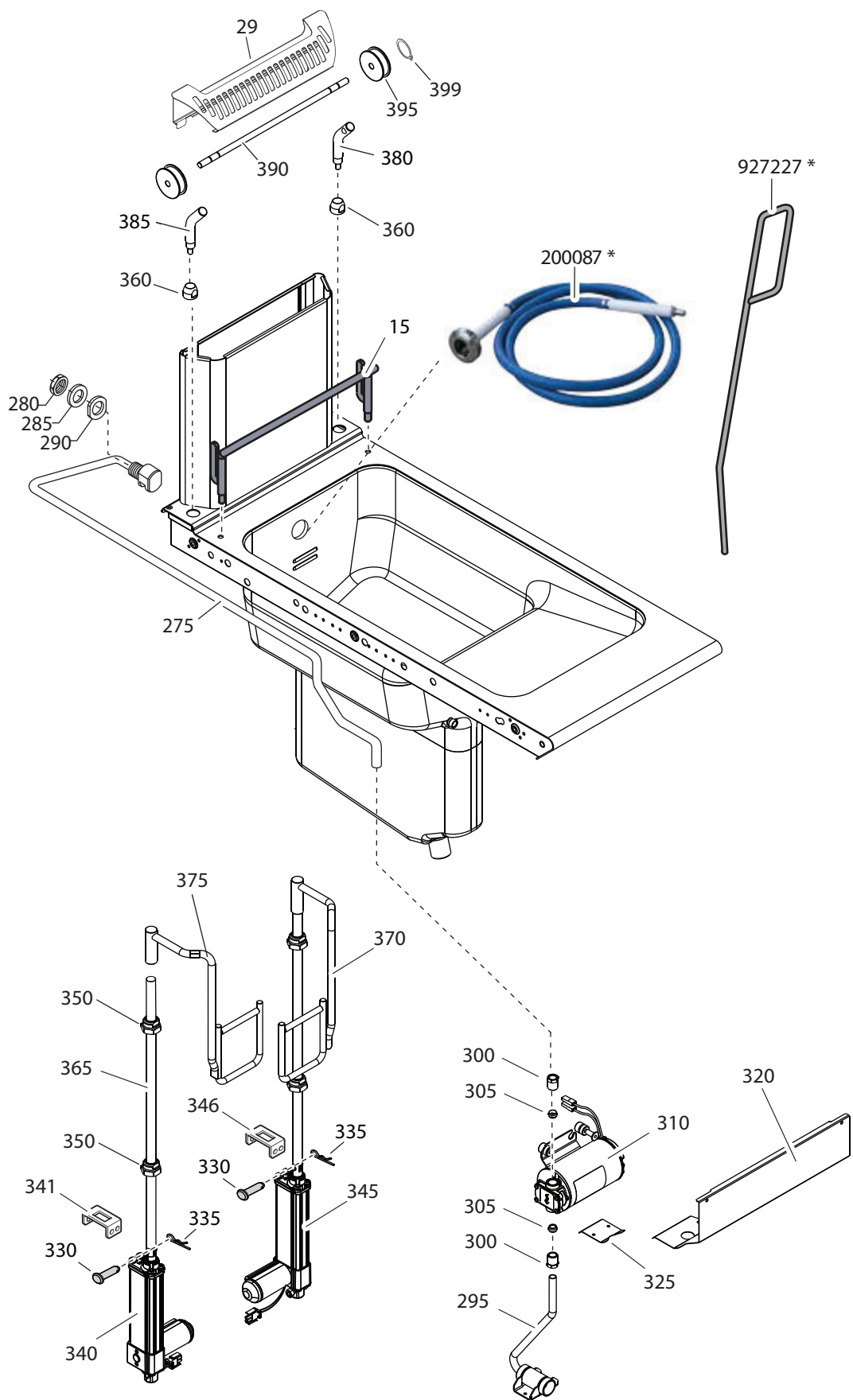

FRIGGITRICI GAS ELETTRONICHE 23LT E 23+23LT 900XP
GAS ELECTRONIC FRYERS 23LT AND 23+23LT 900XP

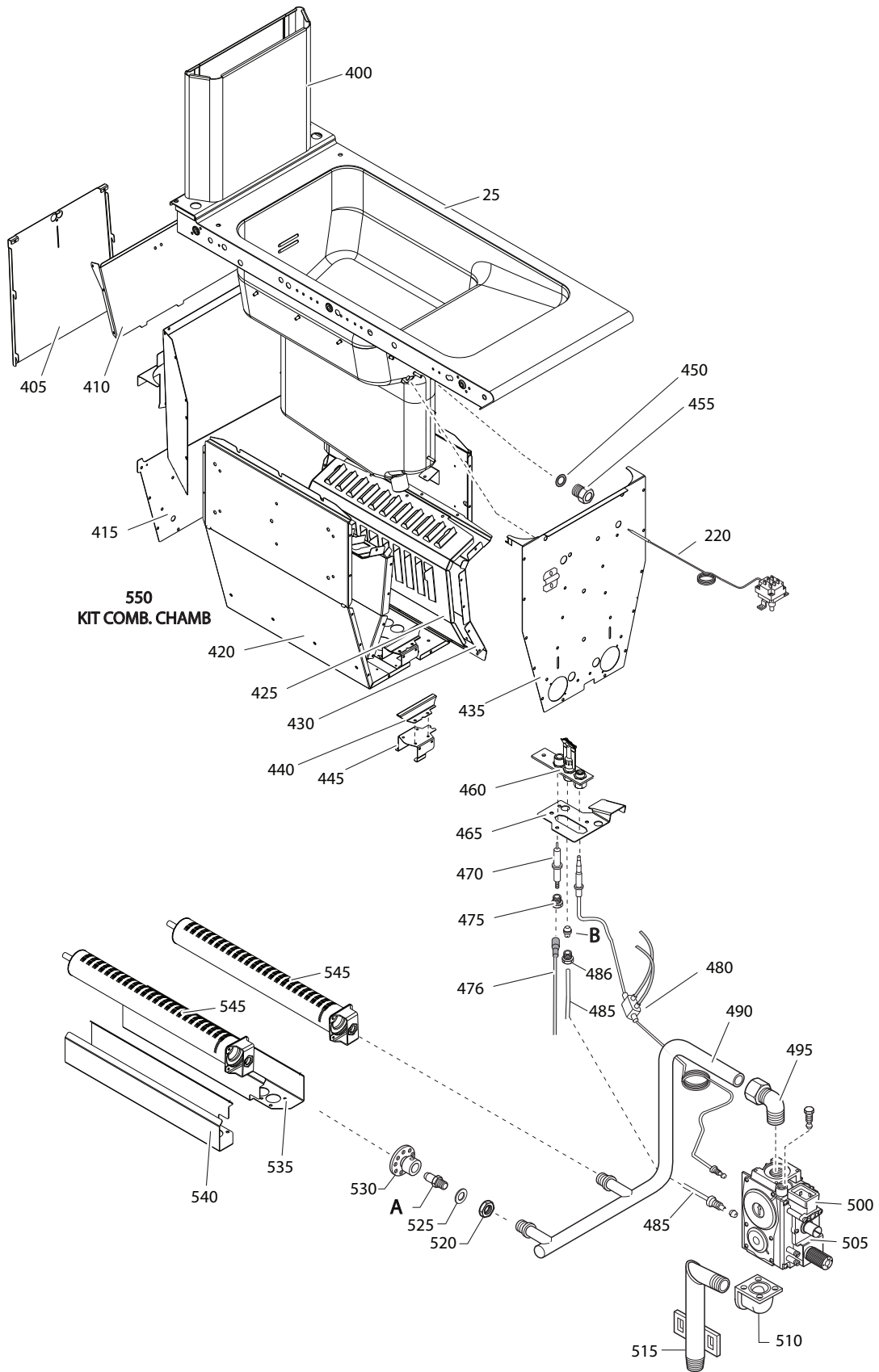

FRIGGITRICI GAS ELETTRONICHE 23LT E 23+23LT 900XP
 GAS ELECTRONIC FRYERS 23LT AND 23+23LT 900XP

Gas type	Category	Power conduct.	Nominal Press	A- BURNER NOZZLE				B - PILOT NOZZLE		
				Aeration adjust						
			mbar	mm	Ø mm	Spare part code	Factory code	Ref.	Spare part code	Factory code
G30 STD-DE	3+3B/P	<u>Max.</u>	30	27,0	1,80	054631	514833600	30	058525	830803600
	3B/P	<u>Max.</u>	50							
G30 PL	3B/P	<u>Max.</u>	37	27,0	1,80	054631	514833600	30	058525	830803600
G20 STD-HU	2H;2E;2Es	<u>Max.</u>	20	31,0	2,90	006419	516844100	40	003327	830810300
	2E(R)B	<u>Max.</u>	25							
G25 STD	2Ei 2E(R)B	<u>Max.</u>	25	31,0	3,20	054084	514831000	40	003327	830810300
G25 DE	2ELL	<u>Max.</u>	20	31,0	3,20	054084	514831000	40	003327	830810300
G25 NL	2L	<u>Max.</u>	25	31,0	3,20	054084	514831000	40	003327	830810300
G25.3 NL	2K	<u>Max.</u>	25	31,0	3,20	054084	514831000	40	003327	830810300
G25.1 HU	2S	<u>Max.</u>	25	34,0	3,20	054084	514831000	40	003327	830810300

FRIGGITRICI GAS ELETTRONICHE 23LT E 23+23LT 900XP
 GAS ELECTRONIC FRYERS 23LT AND 23+23LT 900XP

Pos	Spare part Code	Factory Code	Descrizione	Description	Ref./Note
1	0C0204	835856901	PIEDE	FOOT	
5	0C7366	830825901	CAVETTO SOSTEGNO CRUSCOTTO		
10	0C7307	543831700	GUARNIZIONE – BIANCO	WHITE GASKET	SILIC.5X10MM
10	0C2496	543821900	GUARNIZIONE - GRIGIA	GRAY GASKET	SPONGE 6X2MM
15	006583	516847804	SUPPORTO CESTELLO	BASKET SUPPORT	A, B, E, F, I, J, N, O
20	0CB367	5038AGG01	SCHIENALE	BACK PANEL	C, D, G, H, K, L, O, P
20	0CA081	538844701	SCHIENALE	BACK PANEL	A, B, E, F, I, J, M, N
25		85089JC00	ASS. FIANCO DX	RIGHT PANEL	A, B, C, D, E, F, G, H
25	0C8181	85089JD00	ASS. FIANCO SX	RIGHT PANEL	A, B, C, D, E, F, G, H
25	0CB368	85089JF00	ASS. FIANCO DX	LEFT PANEL	I, J, K, L, M, N, O, P
25	0CB369	85089JG00	ASS. FIANCO SX	LEFT PANEL	I, J, K, L, M, N, O, P
30	*	087089RV00	ASS.VASCA 23L GAS		A, E
30		087089RR00	ASS.VASCA 23L GAS PUMP		B, F
30	*	087089RS00	ASS.VASCA 23L GAS PUMP +LIFT		C, D, G, H
30	*	087089S200	ASS.VASCA 23L GAS		I, M
30	*	087089S100	ASS.VASCA 23L GAS PUMP		J, N
30	*	087089S001	ASS.VASCA 23L GAS PUMP +LIFT ZAN		K, L, O, P
35	0C0156	527850500	PIASTRA FISSAGGIO FIANCHI	SIDE PANEL JOINTING PLATE	
40	006688	835855000	VALVOLA SCARICO	DRAIN VALVE	
45	*	50589K700	SUPPORTO LEVA SCARICO	SUPPORT, DRAIN EXTENSION	
50	0C0608	516868800	PROLUNGA PER SCARICO	DRAIN EXTENSION	
55	006877	508897004	GUIDA PER PROLUNGA SCARICO	GUIDE, DRAIN EXTENSION	
60	0C7220	87089CU03	CRUSCOTTO MARCHIATO (no membrana)	CONTROL PANEL BRANDED (no sticker)	A, B, C, D, E, F, G, H
60	0C7631	87089M902	CRUSCOTTO MARCHIATO (no membrana)	CONTROL PANEL BRANDED (no sticker)	I, J, K, L
60	0C7635	87089MG03	CRUSCOTTO MARCHIATO (no membrana)	CONTROL PANEL BRANDED (no sticker)	M, N, O, P
65	0C8769	54887AH00	MANIGLIA	HANDLE	A, B, C, D, E, F, G, H
66	0C8190	54887A802	MANIGLIA	HANDLE	I, J, K, L
	0A5021	854864203	MANIGLIA	HANDLE	M, N, O, P
70	0C0139	516860901	CERNIERA SUPERIORE	HINGE, UPPER	
75	0C0138	516860801	CERNIERA INFERIORE	HINGE, LOWER	
80	0C7157	50389G300	PORTA DESTRA, PANNELLO	RIGHT DOOR, PANEL	A, B, C, D, E, F, G, H, I, J, K, L
80	*	50389MB01	PORTA DESTRA, PANNELLO	RIGHT DOOR, PANEL	M, N, O, P
85	0C7158	50489CQ00	CONTROPORTA	INNER DOOR	
90	0C0201	830898201	MAGNETE PER PORTA	MAGNET, DOOR	
95	006130	830884701	GRIGLIA DI FONDO	GRATE FOR BOTTOM	
100	0CB341	87589G400	BACINELLA OLIO (CON POMPA)	BASIN FOR OIL (WITH PUMP)	WITH OR, B, C, D, F, G, H, J, K, L, N, O, P
	0CB342	87589FL01	BACINELLA OLIO (SENZA POMPA)	BASIN FOR OIL (WITHOUT PUMP)	A, E, I, M
101	0CB343	85589HC02	FILTRO OLIO (CASSETTINO)	OIL FILTER (SMALL TRAY)	
105	0C2183	543826400	OR	O-RING	3PCS NEEDED, B, C, D, F, G, H, J, K, L, N, O, P
110	0CB344	87589F202	ASSIEME CARRELLO	COMPLETE BASIN	B, C, D, F, G, H, J, K, L, N, O, P
111	0CB346	51489FL01	PRESSORE	FILTER WEIGHT	111+113 = KIT 200084
112	*	1428000	FILTRO CARTA	PAPER FILTER	KIT 200085 (ONLY PAPER, 10PCS IN KIT)
113	0CB347	50489WY00	SUPPORTO FILTRO CARTA	SUPPORT, PAPER FILTER	111+113 = KIT 200084

FRIGGITRICI GAS ELETTRONICHE 23LT E 23+23LT 900XP
 GAS ELECTRONIC FRYERS 23LT AND 23+23LT 900XP

<i>Pos</i>	<i>Spare part Code</i>	<i>Factory Code</i>	<i>Descrizione</i>	<i>Description</i>	<i>Ref./Note</i>
115	0C1014	529889901	COPERCHIO FRIGG.	LID	C, D, G, H, K, L, O, P
115	0C0613	529890101	COPERCHIO FRIGG.	LID	A, B, E, F, I, J, M, N
120	0C0614	511819000	MANIGLIA COPERCHIO	HANDLE, LID	
125	006133	850894500	CESTELLO	BASKET	
130	0C7161	050489JL00	GRIGLIA CAMINO	GRID, CHIMNEY	
135	0C0137	516860702	PIASTRA GIUNZIONE APPARECC.	JOINTING REAR PLATE	
140	0C7163	85589CT03	ASS.PORTINA +MANIGLIA	COMPLETE DOOR WITH HANDLE	A, B, C, D, E, F, G, H
	0C7165	85589CU05	ASS.PORTINA+MANIGLIA	COMPLETE DOOR WITH HANDLE	I, J, K, L
	0C7627	85589CV02	ASS.PORTINA+MANIGLIA	COMPLETE DOOR WITH HANDLE	M, N, O, P
150	0CB348	54887BV01	MEMBRANA ADESIVA	USER BOARD STICKER	B, F
	0CB349	54887BW01	MEMBRANA ADESIVA	USER BOARD STICKER	C, G
	0CB350	54887C001	MEMBRANA ADESIVA	USER BOARD STICKER	K
	0CB351	54887C101	MEMBRANA ADESIVA	USER BOARD STICKER	J
	0CB352	54887C201	MEMBRANA ADESIVA	USER BOARD STICKER	I
	0CB353	54887C600	MEMBRANA ADESIVA	USER BOARD STICKER	M, O
	0CB354	54887C700	MEMBRANA ADESIVA	USER BOARD STICKER	N
	0CB383	54887BU01	MEMBRANA ADESIVA	USER BOARD STICKER	A, E
	0CB384	54887BY01	MEMBRANA ADESIVA	USER BOARD STICKER	D, H
	0CB385	54887C301	MEMBRANA ADESIVA	USER BOARD STICKER	L
	0CB386	54887CA00	MEMBRANA ADESIVA	USER BOARD STICKER	P
155	002670	548836902	PROLUNGA PULSANTE	EXTENSION, SWITCH	
160	0C1812	5168865600	DISTANZIALE SCHEDA INTERFACCIA	SPACER, USER INTERFACE	
165	0CB345	675860V02	SCHEDA MADRE (PREC10)	MOTHER BOARD	
170	0C6364	675860400	SCHEDA INTERFACCIA	USER INTERFACE	
175	0C6380	675851703	SCHEDA ESPANSIONE RELE'	RELE' BOARD	C, D, G, H, K, L, O, P
176	0C6382	699802800	CAVO COMUNICAZIONE SCHEDE	FLAT CABLE	C, D, G, H, K, L, O, P
180	0C1813	546813800	RONDELLA SCHEDA	WASHER, BOARD	10PCS PER PNC
185	006609	675837201	SONDA NTC	NTC PROBE	
186	059295	514874500	PREMISTOPPA	CONNECTION NUT	
187	059293	543815000	GUARNIZIONE OR SONDA OLIO	OR , OIL PROBE	
190	*	50489V901	PROTEZIONE SCHEDA	PROTECTION, MAIN BOARD	
195	050180	246520500	PASSACAVO DIA.23	CABLE LEAD DIA.23	
200	0C3967	624810200	VENTILATORE	MOTORVENTILATOR	
205	*	831840800	GRIGLIA METALLICA VENT.	GRID, MOTORVENTILATOR	
210	058613	A05714000	MORSETTIERA	TERMINAL BOARD	
215	*	806824600	PROTEZIONE CAVO ALIMENTAZIONE	CABLE PROTECTION PIPE	C, D, G, H, K, L, O, P
220	005941	646810002	TERMOSTATO DI SICUREZZA	SAFETY THERMOSTAT	
225	0CB477	694400U00	FILTRO RFI	RADIO DISTURBANCE FILTER	
226	004240	0624804700	ACCENDITORE	IGNITER	
227	*	50289H700	SCHERMO ANTIDISTURBO ACCENDITORE	DISTURBANCE COVER FOR IGNITER	
236	0CB376	655800401	BUZZER 12V	BUZZER 12V	
249	*	50489VA00	SCATOLA IMPIANTO EL	EL BOX	
250	*	0652400B00	PORTAFUSIB	FUSE HOLDER	
250	*	0652400A00	PORTAFUSIB	FUSE HOLDER	
255	0C1480	652803300	FUSIBILE 6,3A	6,3A FUSE	5X20
260	006159	624805601	TRASFORMATORE 220-12V	VOLTAGE ADAPTOR 220-12V	B, C, D, F, G, H, J, K, L, N, O, P

From Ser. Nr. 8041
Up to Ser. Nr.

Ed. document . N° 3 / 09-2018

Page 8

Doc. N°59785VZ00

FRIGGITRICI GAS ELETTRONICHE 23LT E 23+23LT 900XP
 GAS ELECTRONIC FRYERS 23LT AND 23+23LT 900XP

Pos	Spare part Code	Factory Code	Descrizione	Description	Ref./Note
265	006147	675830800	PONTE RADDRIZZATORE	DIODE BRIDGE	B, C, D, F, G, H, J, K, L, N, O, P
270	006610	648806900	RELE'	RELAY	B, C, D, F, G, H, J, K, L, N, O, P
275	0CB358	80589DL00	CONDUTTURA ASPIRAZIONE OLIO	OIL SUCTION PIPE	B, C, D, F, G, H, J, K, L, N, O, P
280	0C1684	516849000	DADO	NUT	B, C, D, F, G, H, J, K, L, N, O, P
285	0C1686	508891200	RONDELLA	WASHER	B, C, D, F, G, H, J, K, L, N, O, P
290	0C3659	516865900	RONDELLA	WASHER	B, C, D, F, G, H, J, K, L, N, O, P
295	0CB357	083089M601	CONDUTTURA CARICO OLIO	PIPE, OIL CIRCULATION	B, C, D, F, G, H, J, K, L, N, O, P
300	006964	514879601	RACCORDO	NIPPLE	B, C, D, F, G, H, J, K, L, N, O, P
305	0CB359	516874402	OGIVA	OLIVE	B, C, D, F, G, H, J, K, L, N, O, P
310	006146	686800003	POMPA OLIO	PUMP, OIL	B, C, D, F, G, H, J, K, L, N, O, P
320	*	50489VB01	CHIUSURA POMPA	PANEL, PUMP	B, C, D, F, G, H, J, K, L, N, O, P
325	*	50589JY00	PROTEZIONE CARICO	TUBE PROTECTION	B, C, D, F, G, H, J, K, L, N, O, P
330	0CB363	219812K01	PERNO CON TESTA Ø 5,9	PIN Ø 5,9	C, D, G, H, K, L, O, P
335	0CB364	219812J00	COPIGLIA DI SICUREZZA 23MM	COTTER PIN 23MM	C, D, G, H, K, L, O, P
340	0CB242	611809G00	ATTUATORE PER SOLLEVAMENTO DX	RIGHT MOTOR ELEVATOR	
341	*	50589CW00	GUIDA ATTUATORE SINISTRA	RUNNER, LEFT MOTOR ELEVATOR	
346	*	50589CV00	GUIDA ATTUATORE DESTRA	RUNNER, RIGHT MOTOR ELEVATOR	
345	0CB241	611809F00	ATTUATORE PER SOLLEVAMENTO SX	LEFT MOTOR ELEVATOR	
350	0CB387	51489FC00	BOCCOLA PER SOLLEVATORI	BUSH, LIFT ROD	
360	0C5086	518817300	BOCCOLA PER SOLLEVATORI	BUSH, LIFT ROD	
365	0CB388	51489FB01	ASTA SOLLEVAMENTO	ROD, LIFT BASKET	C, D, G, H, K, L, O, P
370	0C7198	83089FF01	SUPPORTO DX CESTELLI	RIGHT SUPPORT BASKET	C, D, G, H, K, L, O, P
375	0C7199	83089FG01	SUPPORTO SX CESTELLI	LEFT SUPPORT BASKET	C, D, G, H, K, L, O, P
380	0CB365	51689AJ01	SUPPORTO DESTRO	RIGHT SUPPORT	C, D, G, H, K, L, O, P
385	0CB366	51689AH01	SUPPORTO SINISTRO	LEFT SUPPORT	C, D, G, H, K, L, O, P
390	0C1027	516866500	BARRA SUPPORTO CESTELLI	ROD, BASKET SUPPORT	C, D, G, H, K, L, O, P
395	0C1028	516849400	RUOTA GUIDA ASTA SOLL.	WHEEL, ROD LIFTER	C, D, G, H, K, L, O, P
399	067004	219001015	ANELLO SEEGER	SEEGER RING	C, D, G, H, K, L, O, P
400	0C6105	851805400	ASS. PROLUNGA CAMINO	CHIMNEY EXTENSION	
405	*	529825601	PARETE POST. CAMINO	BACK PANEL CHIMNEY	
410	*	529825701	PARETE ANT. CAMINO	FRONT PANEL CHIMNEY	
415	*	50489UQ00	PARETE POST. CAM. COMB.	BACK PANEL COMB.CHAMBER	
420	*	085589NB01	FASCIA CAMERA DI COMBUSTIONE	PANEL, COMB.CHAMBER	
425	*	050489X601	DEFLETTORE	DEFLECTOR	
430	*	50489X501	CONVOGLIATORE FUMI SX / DX	LEFT/RIGHT FUME CONVEYOR	
435	*	50489UK00	PARETE ANT. CAM. COMB.	FRONT PANEL COMB.CHAMBER	
440	*	050489U501	CONVOGLIATORE GAS PILOTA	PILOT CONVEYOR	
445	*	50689FK01	SUPPORTO PILOTA ASSIEME	PILOT SUPPORT	
450	59293	543815000	GUARNIZIONE OR	OR GASKET	
455	59295	514874500	RACCORDO BULBO	CONNECTOR PROBE	
460	54032	830828100	BRUCIATORE PILOTA	PILOT BURNER	
465	*	050489U300	CHIUSURA PILOTA	PILOT BRACKET	
From Ser. Nr. 8041 Up to Ser. Nr.			Ed. document . N° 3 / 09-2019	Page 9	Doc. N°59785VZ00

FRIGGITRICI GAS ELETTRONICHE 23LT E 23+23LT 900XP
 GAS ELECTRONIC FRYERS 23LT AND 23+23LT 900XP

<i>Pos</i>	<i>Spare part Code</i>	<i>Factory Code</i>	<i>Descrizione</i>	<i>Description</i>	<i>Ref./Note</i>
470	052610	330272401	ELETTRODO (candela)	CANDLE , IGNITER	
475	057960	214164101	RACCORDO ELETTRODO	CONNECTOR, IGNITER	
476	0CB395	634805200	CAVETTO ACCENDITORE valvola/candela	IGNITER CABLE valve/candle	
480	0CA280	83089L700	TERMOCOPPIA INTERROTTA	THERMOCOUPLE	With micro
485	0CB244	051589CG00	CONDUTTURA PILOTA	PILOT GAS PIPE	
486	020997	214105101	CONTRODADO PORTAUGELLO	NOZZEL HOLDER	
490	*	835861200	RIBALTA GAS	MANIFOLD GAS PIPE	
495	006622	517866200	RACCORDO "L"	ELBOW PIPE	
500	054539	830831400	MICROINTERR. VALVOLA GAS	MICRO, GAS VALVE	
505	002903	835819901	VALVOLA GAS, COMPLETO (con micro e cavetto accenditore)	COMPLETE GAS VALVE (with micro and igniter cable)	
510	0A5398	830866100	RACCORDO	CONNECTOR	
515	0C3130	835861200	CONDUTTURA ENTRATA GAS	INLET GAS PIPE	
520	020997	214105101	CONTRODADO	NUT STOPPER	
525	054029	506833401	GUARNIZIONE PER UGELLO	NOZZLE GASKET	
530	054039	830828001	AERATORE	AERATOR (primary air)	
535	*	50689G901	CONVOGLIATORE BRUC. DESTRO	RIGHT BURNER CONVEYOR	
540	*	50689FP01	CONVOGLIATORE BRUC. SINISTRO	LEFT BURNER CONVEYOR	
545	0CA281	083089L901	BRUCIATORE	BURNER	
550	0CB389	85589HT03	CAMERA DI COMBUSTIONE CON CAMINO ASSEMBLATO	COMPLETE ASSEMBLED COMBUSTION CHAMBER	
*		921023	FILTRO SEDIMENTI FONDO	SEDIMENT FILTER	
*		960645	DEFLETTORI FARINA	DEFLECTORS, FLOUR	
*		200087	TUBO POMPA SCARICO OLIO	PIPE DRAIN PUMP OIL	
*		927227	TUBO OTTURAZIONI	UNCLOGGING ROD	
From Ser. Nr. 8041 Up to Ser. Nr.			Ed. document . N° 3 / 09-2018	Page 10	Doc. N°59785VZ00



Electrolux Professional SPA
Viale Treviso 15
33170 Pordenone
www.electrolux-professional.com

NordCap GmbH & Co. KG
Thalendorststraße 15
28307 Bremen
Hauptsitz (Service, Finanzen & Personal, Lager, IT, Marketing)

Telefon: +49 421 48557-0
Telefax: +49 421 488650
E-Mail: bremen@nordcap.de

Die NordCap Verkaufsniederlassungen in Deutschland:

Nord: Hamburg • Ost: Berlin • Süd: Ingelheim • West: Erkrath

by **NordCap**[®]

ZANUSSI
PROFESSIONAL