

Ersatzteilliste-Explosionszeichnung

Schnellkühler / Schockfroster SF 200/170-Z-LW-ERZ



BLAST CHILLER- FREEZER

RANGE BCF ROLL IN 150 - 200 Kg

Type Reference	Ref	Page	Description
SKCH200B	a	2 to 5	BCF 200/170KG 20 GN 2/1 - ROLL-IN built in 380/400V 50HZ
SKCH150B	b	2 to 5	BCF 150/120KG 20 GN 2/1- ROLL-IN built in 380/400V 50HZ
SKCH150R	c	2 to 5	BCF 150/120KG 20 GN 2/1- ROLL-IN 380/400V 50HZ
SKCH200R	d	2 to 5	BCF 200/170KG 20 GN 2/1 - ROLL-IN remote 380/400V 50HZ
SKCHU200R	e	2 to 5	BCF 200/170KG 20 GN 2/1 - ROLL-IN remote USA 208/60hz

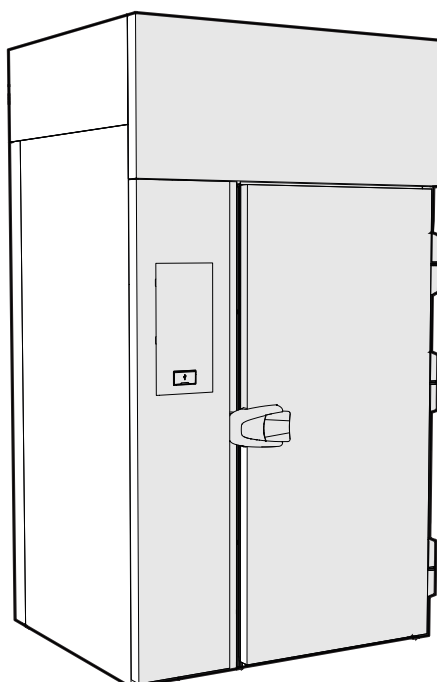

Index

Identification "type ref"/identificazione "type ref"	2
Exploded view body part / Vista esplosa corpo	3
Exploded view evaporator/ Vista esplosa parte evaporante	4
Exploded view cooling unit/ Vista esplosa gruppo refrigerante	5
Control panel/pannello comandi	6
Spare part list/Lista ricambi	7 to 11

...Bold= last change/Grassetto =ultima modifica

Rev. 3

From Ser. Nr.... Up to Ser. Nr....	Ed. 2019-05 Updated 2024-02	Page: 1	Doc No: 595R51900
---------------------------------------	--------------------------------	---------	--------------------------

How to put in relation the “Type Ref.” reported on the data plate with the “Type reference” reported on the front page of the Spare Part Catalogue:

The “Type Ref.” represents a group of models/brands all with similar technical features, hence possible to be reported under the same scheme in terms of exploded views.



SKCH

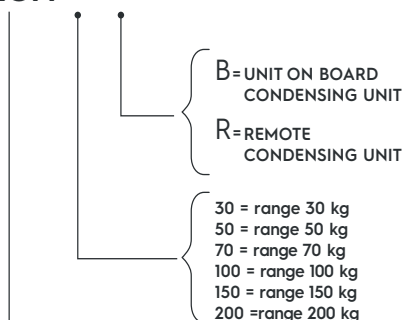

**B=UNIT ON BOARD
CONDENSING UNIT**

**R=REMOTE
CONDENSING UNIT**

30 = range 30 kg
50 = range 50 kg
70 = range 70 kg
100 = range 100 kg
150 = range 150 kg
200 = range 200 kg

**SKCH = SKYLINE CHILLER\FREEZER
(EUROPA\SAUDI ARABIA\KOREA)**

**SKCHU = SKYLINE CHILLER\FREEZER
(NORD AMERICA)**

ES : **SKCH30B** = range 30 kg gn 1\1 with cooling unit (europa etc.)
SKCH30R = range 30 kg gn 1\1 without cooling unit (remote) (europa etc.)
SKCHU30B = range 30 kg gn 1\1 with cooling unit (nord America)
SKCHU30R = range 30 kg gn 1\1 without cooling unit (remote) (nord America)

Find below an identification example: SKCH30B

F.Mod. PNC 9VTX.....	Comm.Model Ser.Nr.....	Type Ref. SKCH30B	2019
W.Tot. kW	Volt.....	Hz.....	Cyclopentane Total Current A
Evaporation Heater El. kW	Class x	GWP	CO2-eq t
Lighting W	Cap.	Refrigerant	Kg
Defrost Power kW	Heating power kW		
NF nominal Charge			
Rated Pressure Mpa		CE	WEEE
IPX4			
Electrolux Professional SPA - Viale Treviso, 15 - 33170 Pordenone (Italy)			

For the right spare code identification follow the steps:

1. Type in the website the PNC reported on the data plate.
2. The website will automatically display this spare part catalogue.
3. The spare part code at this point is referenced through the “Type reference” as from the front page by the relevant “Ref”.

Come mettere in relazione il “Type Ref.” Riportato sulla targhetta caratteristica con il “Type reference” riportato sul frontespizio del catalogo ricambi:

Il “Type Ref.” Rappresenta un gruppo di modelli/marchi con simili caratteristiche tecniche, ossia possibili da rappresentare con il medesimo schema in termini di vista esplosa.



SKCH

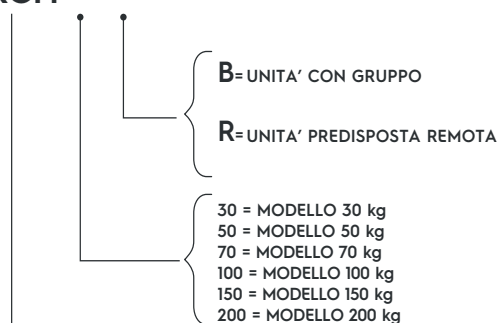

B=UNITA' CON GRUPPO

R=UNITA' PREDISPOSTA REMOTA

30 = MODELLO 30 kg
50 = MODELLO 50 kg
70 = MODELLO 70 kg
100 = MODELLO 100 kg
150 = MODELLO 150 kg
200 = MODELLO 200 kg

**SKCH = SKYLINE CHILLER\FREEZER
(EUROPA\SAUDI ARABIA\KOREA)**

**SKCHU = SKYLINE CHILLER\FREEZER
(NORD AMERICA)**

ES : **SKCH30B** = range 30 kg gn 1\1 con gruppo (europa etc.)
SKCH30R = range 30 kg gn 1\1 predisposto remoto (europa etc.)
SKCHU30B = range 30 kg gn 1\1 con gruppo (nord America)
SKCHU30R = range 30 kg gn 1\1 predisposto remoto (remote) (nord America)

Qui di seguito un esempio di identificazione: SKCH30B

F.Mod. PNC 9VTX.....	Comm.Model Ser.Nr.....	Type Ref. SKCH30B	2019
W.Tot. kW	Volt.....	Hz.....	Cyclopentane Total Current A
Evaporation Heater El. kW	Class x	GWP	CO2-eq t
Lighting W	Cap.	Refrigerant	Kg
Defrost Power kW	Heating power kW		
NF nominal Charge			
Rated Pressure Mpa		CE	WEEE
IPX4			
Electrolux Professional SPA - Viale Treviso, 15 - 33170 Pordenone (Italy)			

Per identificare il corretto codice ricambio procedere con:

1. Digitare nel website il PNC riportato sulla targhetta caratteristica.
2. Il website mostrerà automaticamente questo catalogo ricambi.
3. A questo punto, il codice ricambio è identificabile attraverso il “Type reference” come indicato nel frontespizio sotto la relativa voce “Ref”.

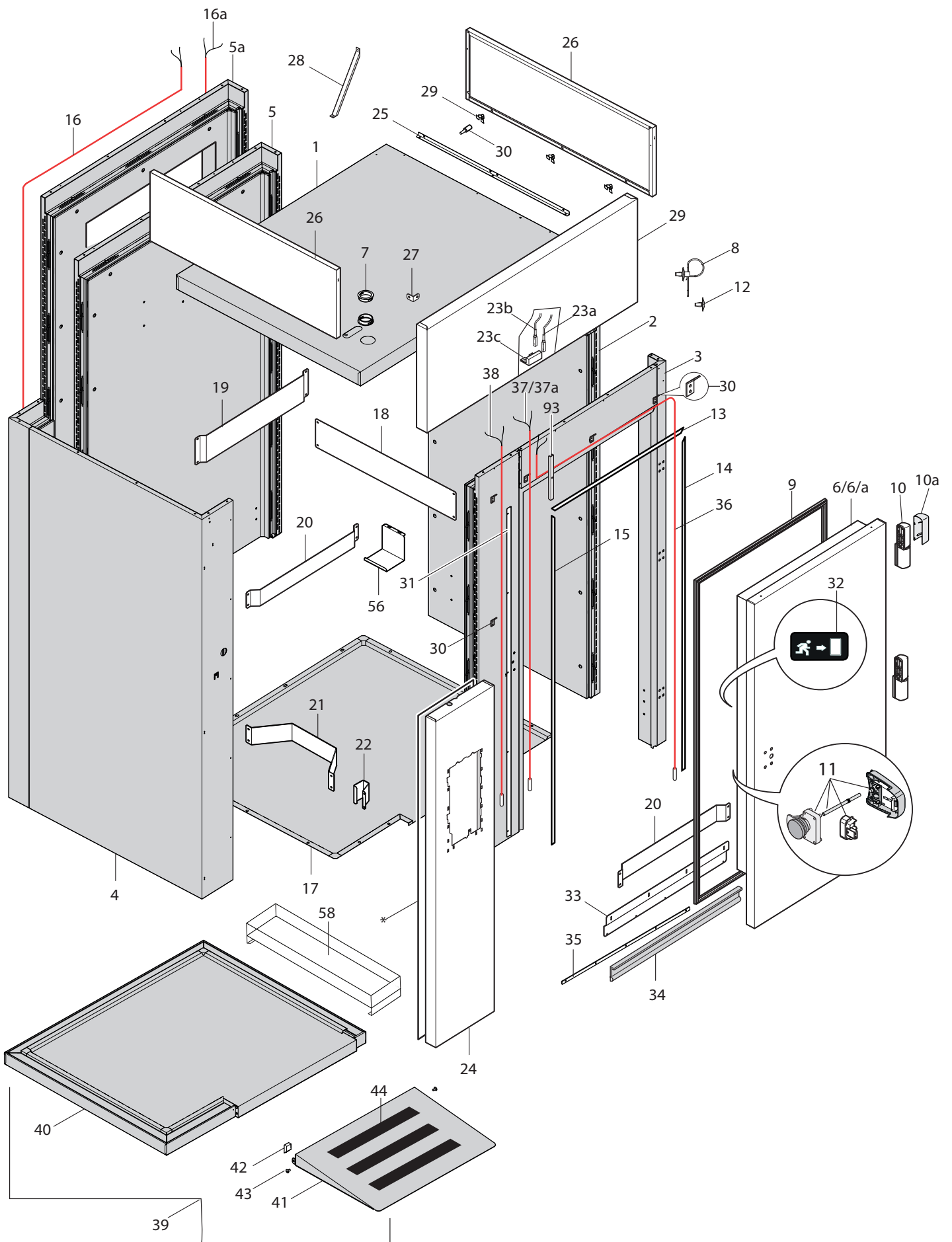

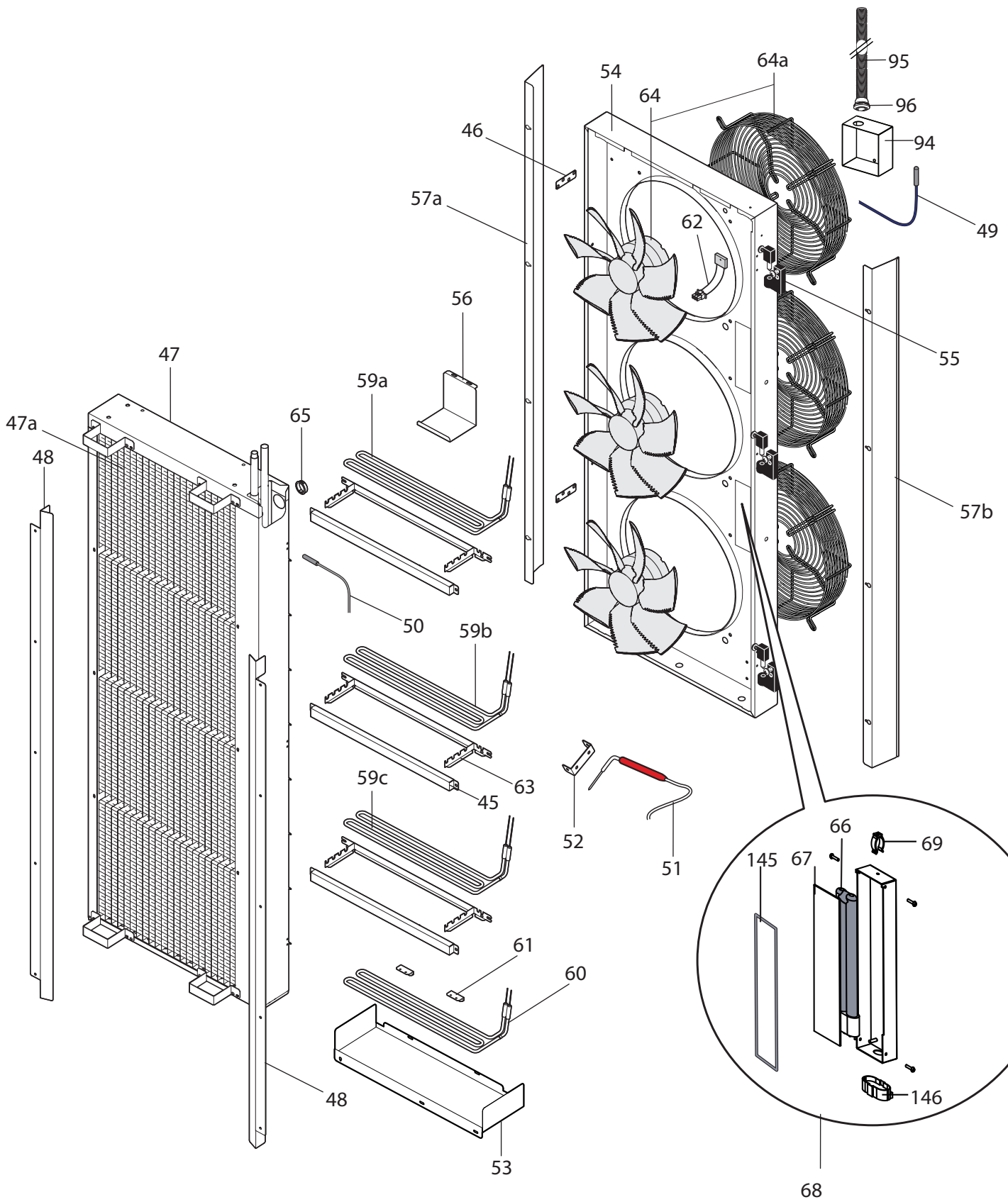

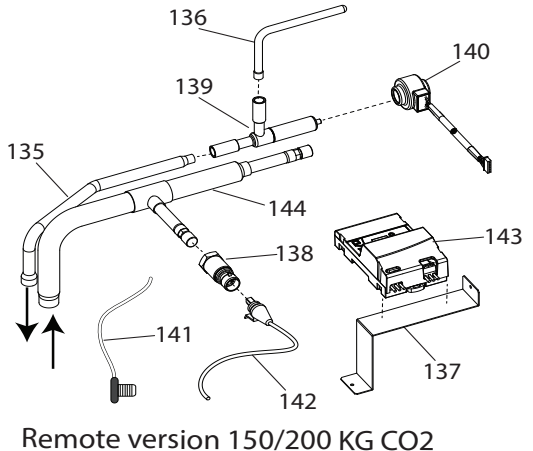
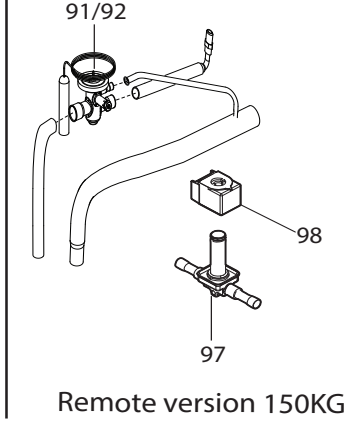
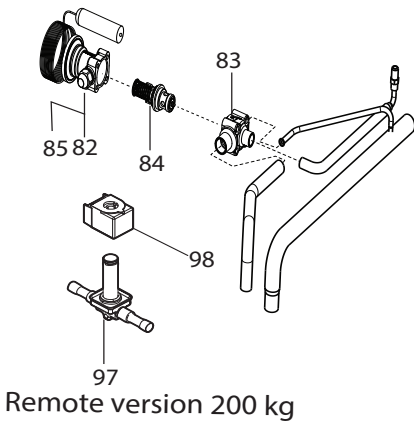
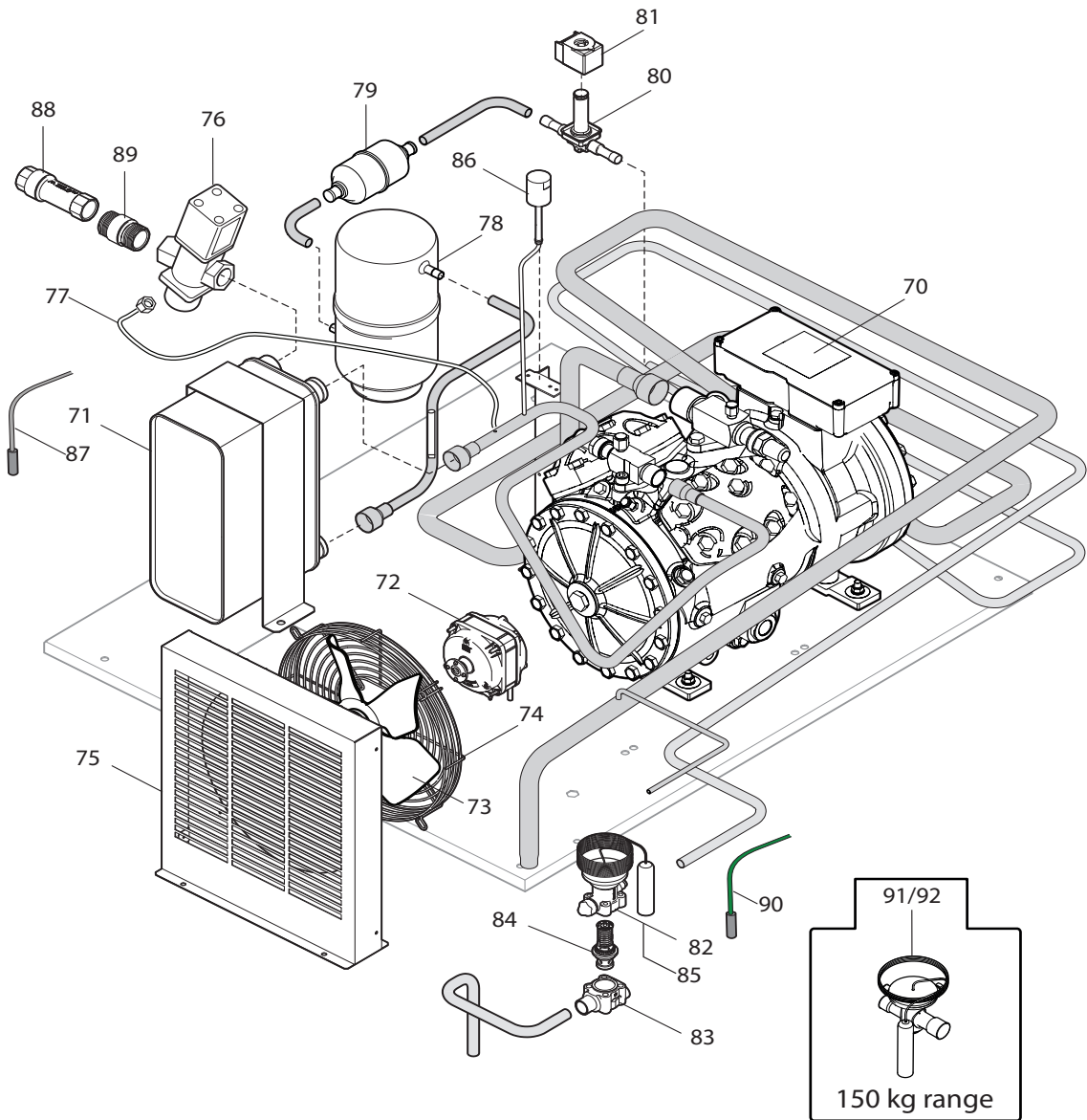

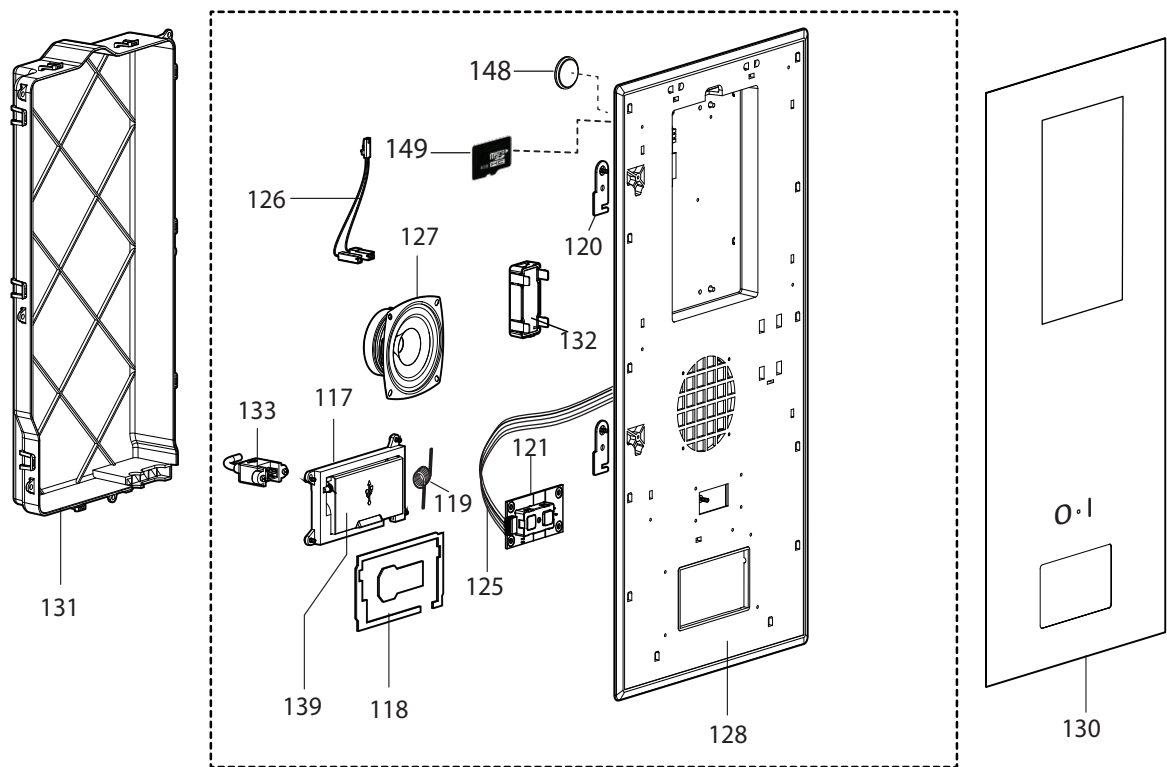
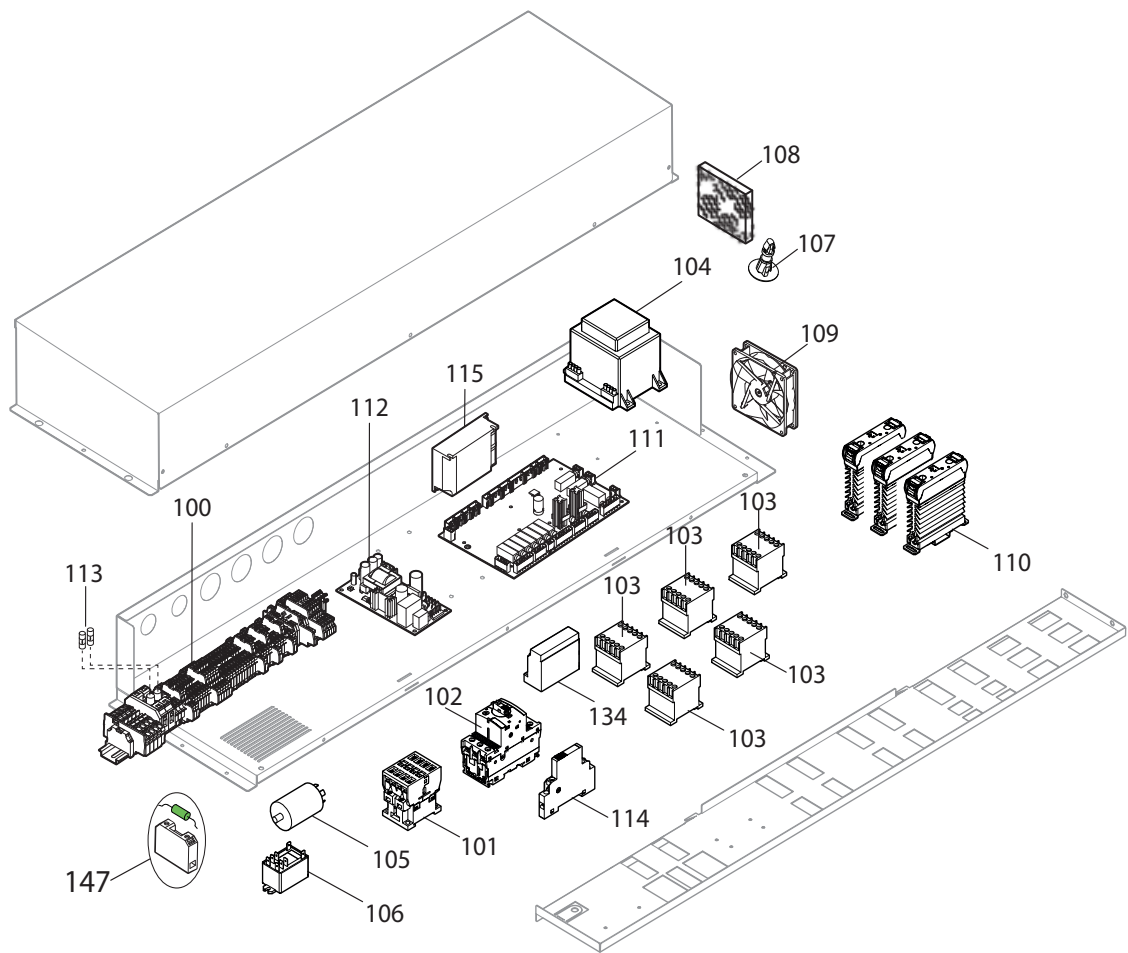

note: replacing n°128 order also 130

116

Pos	Code	Factory code	Description	Descrizione	Ref/notes
1	096403	0835R72502	Upper panel	Pannello superiore	
2	096399	0835R23503	Right panel	Pannello destro	
3	096400	0835R23604	Door panel	Pannello per porta	
4	096398	0835R74300	Left panel	Pannello sinistro	
5	096401	0835R23802	Back panel standard	Pannello schienale standard	
5a	096402	0835R24704	Back panel to pass-through	Pannello schienale passante	
6	096505	0877789807	Door standard right	Porta dx standard	
6a	095491	0877794303	Door left to pass-Through	Porta sx per passante	
7	0L3177	0639735400	Wiring bush	Passacavo uscita cavi	
8	095928	0C03010591	Opening clamp	Fascetta apribile "messicano"	Up to 2020/21
8		0639622800	Opening clamp	Fascetta apribile "messicano"	From 2020/22
9	099168	0547751201	Gasket door 849.5x1815.5	Guarnizione porta 849.5x1815.5 mm	
10	094731	0833R34900	Hinge door assembled	Cerniera porta completa	
10a	097267		Hinge cover	Copertura cerniera	
11	094730	0833R34800	Door closer complete	Chiusura porta completa	
12	091507	0549741500	Plug for panels	Tappo per pannelli	
13	093956	0501747501	Frame upper support	Cornice traversa superiore	
14	090028	0512740401	Vertical frame "right"	Cornice verticale destra	
15	095581	0502R17800	Vertical frame "left"	Cornice verticale sx	
16	096368	0617R27000	Heater frame door right 2680 mm 40.2 W	Cavo riscaldante dx 2680 mm 40.2 W	c,d,e pass-through EU-USA
16a	096369	0617R26900	Heater frame door left 1850 mm 27.8 W	Cavo riscaldante sx 1850 mm 27.8 W	c,d,e pass-through EU-USA
17	096381	0882R68101	Bottom panel	Basamento standard	
17		0882R94600	Bottom panel	Basamento standard	With insulated floor + ramp
17		0883R21200	Bottom panel	Basamento standard	Pass-through from 2020/22
18	089842	0512759203	Right side bumper	Paracolpi laterale dx	
18	090163	0512777201	Right side bumper	Paracolpi laterale dx	Pass-through from 2020/22
19	089843	0512759501	Back upper bumper	Paracolpi superiore schienale	
19	090163	0512777201	Back upper bumper	Paracolpi superiore schienale	Pass-through from 2020/22
20	089844	0512759402	Back lower bumper and door bumper	Paracolpi porta e schienale	
21	096304	0504R16000	Left side bumper	Paracolpi sx carter	Up to 2020/21
21	089845	0512759102	Left side bumper	Paracolpi sx carter	From 2020/22
21	090164	0805770501	Left side bumper	Paracolpi sx carter	From 2020/22 pass-through
22	096303	0504R14700	Left inlet bumper	Paracolpi sx entrata	
23a	096002	0640R04101	Door microswitch	Sensore porta	
23b	095929	0646R20601	Magnetic sensor UV lamp	Sensore magnetico lampada UV	d,e for UV lamp
23c	087533	0640712000	Magnet STEM	Magnete STEM	d,e UV lamp from 2022/29
24	096328	0850R25501	Vertical control panel electrolux	Cruscotto verticale electrolux	electrolux
24	096371	0850R25601	Vertical control panel other brand	Cruscotto verticale other brand	all brand
25	096196	0505R12601	Support corner	Angolare fissaggio laterale	
26	093957	0512748506	Upper side panel "left and right"	Pannelli superiori dx e sx	a,b
26	094758	0512748906	Upper side panel "left and right"	Pannelli superiori dx e sx	c,d,e
27	096197	0505R15000	Upper small bracket for upper side panel	Staffa piccola per pannelli superiori	
28	0TTZXM	0505R13100	Upper bracket for upper side panel	Staffa per pannelli superiori	
29	096346	0509R25800	Upper Dashboard	Pannello superiore	a,b up to 2022/28
29	097534	0509R25801	Upper Dashboard	Pannello superiore	a,b from 2022/29
29	095604	0509R15204	Upper Dashboard	Pannello superiore	c,d,e up to 2020/26
29		0509R15301	Upper Dashboard	Pannello superiore	c,d,e pass-through from 2020/27
30	093793	0505R12800	Bracket for upper dashboard	Staffetta per cruscotto superiore	

Pos	Code	Factory code	Description	Descrizione	Ref/notes
31	094761	0501R63501	Vertical protection heater	Protezione verticale resistenza	
32	094732	0598R66200	Sticker internal door	Adesivo interno porta	Up to 2020/21
32		0598R97900	Sticker internal door	Adesivo interno porta	From 2020/22
33	090029	0512748101	Lower gasket support door	Guida guarnizione porta inferiore	
34	099167	0547748701	Lower gasket door	Guarnizione inferiore porta	
35	089840	0512748003	Gasket lower support door	Supporto inferiore guarnizione porta	
36	096347	0617R26301	Heater frame door right 2700 mm 40.2 W	Cavo riscaldante dx 40.2 W	
36		0617R03H00	Heater fr. door right 43.2 W 2880 mm	Cavo riscaldante dx 43.2 W	d 2x20
37	096361	0617R28000	Heater frame door left 27.8 W 3350 mm	Cavo riscaldante cornice sx 27.8 W	
37a	096347	0617R26301	Heater fr. used with ramp 40.2 W 2700 mm	Cavo riscaldante dx e con rampa 40.2 W	
38	096200	0617R26200	Heater left door panel 27.8 W 2850 mm	Cavo riscaldante pannello 27.8 W	
39	096540	0835R32Q00	Foamed bottom complete	Ass. fondo schiumato completo	
40	096214	0835R34901	Foamed bottom	Fondo schiumato	
41	096213	0833R27900	Ramp	Rampa	
42	096195	0502R40700	Heater frame cover ramp	Protezione resistenza rampa	
43		0217045145	Screws M8X16 AISI 304	Vite M8X16 AISI 304	
44	096316	0546R31700	Anti-slip roll	Rotolo antiscivolo	
45	096194	0501R47400	Heater hand protection	Protezione mani resistenze	
46	096198	0505R15100	Locking bracket	Piattina di chiusura	
47	096380	0858R17601	Evaporator with covers in stainless steel	Evaporatore con coperture	
47	097262	0858R18600	Evaporator with covers in stainless steel	Evaporatore con coperture	c,d CO2
47a	089859	0840706703	Evaporator	Evaporatore	
47a	097622	0830R02T00	Evaporator	Evaporatore	c,d CO2
48	093824	0501R46300	Vertical splash guard right_left	Paraspruzzi verticale evaporatore	
49	096205	0646R21600	Cavity sensor blu color	Sonda 6X20 blu 'CELL' resinata	
50	096206	0646R21700	Evaporator sensor grey color	Sonda 6X20 grigia 'evaporatore' resinata	
51	096208	0646R22200	Food probe 3 sensors	Spillone conico 3 punti	a,b,c,d
51	096431	0653R00000	Food probe 3 sensors	Spillone conico 3 punti	e
52	089860	0506748800	Food probe support	Supporto sonda spillone	
53	093823	0805768305	Evaporator water collector	Bacinella raccolta condensa evaporatore	Up to 2020/21
53	096555	0805R00H01	Evaporator water collector	Bacinella raccolta condensa evaporatore	From 2020/22
54	096193	0858759802	Carter evaporator	Carter evaporatore	Up to 2020/26
54	096554	0850R04A00	Carter evaporator	Carter evaporatore	From 2020/27
54	097527	0501R73402	Carter evaporator	Carter evaporatore	e with UV lamp
55	090040	0830764200	Carter hinge	Cerniera carter evaporatore	
56	096308	0504R16900	Wiring protection	Protezione cavi evaporatore	
57	096192	0512716401	Air conveyor	Convogliatore aria	Up to 2020/21
57a	096544	0504R19201	Left air conveyor	Convogliatore aria sx	From 2020/22
57b	097041	0502R08L00	Right air conveyor	Convogliatore aria dx	From 2020/22
58	091292	0833R12600	Water manual collector	Bacinella manuale di raccolta condensa	
59a	097258	0617R03S00	Upper defrost heater 1000 Watt 230V	Resistenza di sbrinamento superiore 1000 Watt 230V	a,b,c,d
59a	093231	0617727701	Upper defrost heater 1000 Watt 208V	Resistenza di sbrinamento superiore 1000 Watt 208V	e
59b	097257	0617R03R00	Central defrost heater 1000 Watt 230V	Resistenza di sbrinamento centrale 1000 Watt 230V	a,b,c,d
59b	093231	0617727701	Central defrost heater 1000 Watt 208V	Resistenza di sbrinamento centrale 1000 Watt 208V	e

Pos	Code	Factory code	Description	Descrizione	Ref/notes
59c	093228	0617724102	Lower defrost heater 1000 Watt 230V	Resistenza di sbrinamento inferiore 1000 Watt 230V	a,b,c,d
59c	093231	0617727701	Lower defrost heater 1000 Watt 208V	Resistenza di sbrinamento inferiore 1000 Watt 208V	e
60	089863	0617724001	Bottom evaporator heater 1500 Watt 230V	Resistenza sotto evaporatore 1500 Watt	a,b,c,d
60	096356	0617R27500	Bottom evaporator heater 1500 Watt 208V	Resistenza sotto evaporatore 1500 Watt	e
61	095762	0512717400	Stopper bottom evaporator heater	Fissaggio resistenza sotto evaporatore	
62	096210	0652R02601	Safety thermostat 93°C 120 VDE	Termofusibile 93°C VDA	a,b,c,d
62	096365	0652R02901	Safety thermostat 93°C 120 UR	Termofusibile 93°C UR	e
63	096191	0512713501	Defrost heater support	Supporto resistenza	
64	084914	0682708602	Cavity fan 400V 50/60Hz 1350/1050Rpm	Ventilatore cella 400V 50/60Hz 540/360W	a,b,c,d
64	099172	0682719401	Cavity fan 208V 50/60Hz 1350/1050Rpm	Ventilatore cella 208V 50/60Hz 540/360W	e
64a	096311	0514R29200	Protection cavity fan aisi	Griglia di protezione ventilatore AISI	e
65	094001	0639711100	Wiring hole protection	Passacavo	
66	093949	661R01100	UV lamp 18W2G11	Lampada UV 18 W	
67	093097	549R05400	Glass for uv lamp	Vetro per lampada UV	
68	097537	0832R28500	ASS. UV LAMP	ASSIEME LAMPADA	e with UV lamp
69	084384	0624705200	PLASTIC SPRING	MOLLE PE LAMPADA	e with UV lamp
70	096212	0684R13500	Compressor H751CS	Compressore H751CS	a
70	097074	0684R15100	Compressor H505CS	Compressore H505CS	b
70	096549	0684R13400	Compressor H705CS	Compressore H705CS	b 60 Hz
70	096550	0684R15000	Compressor H751CS	Compressore H751CS	a 60 Hz
71	084899	0830766700	H2O condenser B10THx 70P	Condensatore ad acqua B10THx 70P	a
71	084939	0830763700	H2O condenser B10THx 40P	Condensatore ad acqua B10THx 40P	b
72	096211	0682R13600	Fan condenser motor	Ventilatore condensatore	
73	084781	0511704700	Fan D 254/28°	Ventola D 254/28°	
73	094955	0511R01900	Fan D 254/31°	Ventola D 254/31°	a,b 60 Hz
74	092651	0514R07500	Grid protection fan condenser	Griglia ventilatore	
74	096468	0514R05A00	Grid protection fan condenser	Griglia ventilatore	a,b 60 Hz
75	096343	0504R03701	Support protection fan	Protezione ventilatore	
76	092277	0646R09100	Pressostatic valve H2O V46 AC 9300	Valvola pressostatica H2O V46 AC 9300	Up to 2024/05
76	09A1NB	0646R07A00	Pressostatic valve DANFOSS WVFX10 (003N1105)	Valvola pressostatica DANFOSS WVFX10 (003N1105)	From 2024/06
77	096199	0515R22300	Cappillary 1.5M 1/4' for press. valve	Cappillare 1,5 M racc. 1/4' press.valvola	
78	083468	0805725601	Tanic reciver LT 2.3	Recivitore di liquido LT 2.3	
79	090046	0805766400	Filter DLC	Filtro DLC	
80	089867	0646759600	EVR 10 Valve 12 mm	Valvola EVR 10 12mm	
81	088351	0646749000	BoB.clip 10W EVR6 230/230 50/60hz	Bobina 10W EVR6 230/230 50/60hz	
82	085447	0646729600	Thermostatic element TES5 67B3357	Elemento termostatico TES5 67B3357	a,d (gas R452/404)
82	096364	0646R23200	Thermostatic element TES5 067B3252	Elemento termostatico TES5 67B3357	d,e (gas R448/449/407c)
83	096202	0646R20400	Body Valve to solder 067B4002 12/16	Corpo valvola a saldare 067B4002 12/16	a,d,e
84	084906	0646727300	Orifice 02 67B2790	Orificio valvola N°2 67B2790	a,d,e
85	096315	0544R10000	Insulation valve, thermich insulation	Protezione valvola , isolamento termico	a,d,e
86	096201	0646R20300	Pressostat AC 250V OFF 31 bar On 24 bar	Pressostato 250V OFF 31 bar On 24 bar	
87	096204	0646R21500	Probe condenser Black	Sond condensatore nera	
87	096321	0646R22300	Probe condenser Black	Sonda condensatore nera	e
88	0L2980	0652608800	Double non-return valve AVG 2NV20-20 FXF	Doppia valvola di ritegno AVG 2NV20-20 FXF	
89	072457	0W00526300	Joint 3/4X3/4MM	Raccordo 3/4X3/4MM	
90	096207	0646R21800	OUT probe green color	Sonda "OUT evap" di colore verde	
91	096203	0646R20500	Thermost. valve or.3 con attacchi1/2 x 5/8	Valvola termost. or.3 con attacchi1/2 5/8	b,c R452a/404a

Pos	Code	Factory code	Description	Descrizione	Ref/notes
92	096314	0544R09900	Insulation valve, thermich insulation	Protezione valvola , isolamento termico	b,c
93	096306	0504R16600	Heating cables cover BCF 150/200 JJ	Protezione cavi bcf	
94	096300	0504R12601	Protection box cavity fan UL	Calotta di protezione ventilatore cella UL	e
95	097538	0835R76600	Flexible metal conduit SS L=0.27m UL	Tubo in ss per cavi ventilatori UL	e
96	096313	0544R09800	Connection of fitting and conduit M20x15	Raccordo per tubo in SS ventilatori UL	
97	089867	0646759600	EVR 10 Valve 12 mm usa UL	Valvola EVR 10 12mm UL	
98	099180	0858741600	BoB.coil 208-240V 50-60HZ UL	Bobina 10W EVR6 230/230 50/60hz UL	e
100	096362	0639R21701	Complete clamp /150/200 kg	Morsettiera completa 150/200KG	a,b
100	096319	0639R22002	Complete clamp /150/200 kg	Morsettiera completa 150/200KG	c,d,e
101	090064	0648729600	Contacto B&J K3-22 A10-230	Contattore B&J K3-22 A10-230	a,b,c,d
102	096322	0648R11500	Motor protective switch MS132-25 (20-25A)	Salvatore ABB MS132-25 (20-25A)	a
102	093194	0640R01900	Motor protective switch MS132-20 (16-20A)	Salvatore ABB MS132-20 (16-20A)	b
103	088557	0648727100	Contacto K1-09D10 230 (COIL 220-230/50 240/60)	Teleruttore K1-09D10 230 (COIL 220-230/50 240/60)	a,b,c,d
103	090099	0648729300	Contacto K1-09D10 230 (COIL 200/50 240/60)	Teleruttore K1-09D10 230 (COIL 200/50 240/60)	e
104	093625	0624R01700	Voltage adaptor 230/42V 170VA	Trasformatore 230/42V 170VA	a,b,c,d
104	096430	624R00A00	Voltage adaptor 208/42V 170VA	Trasformatore 208/42V 170VA	e
105	084987	0694700800	Filter (L.C)	Filtro elettrico 411.5.14.41.0 (TIPO L-C)	a,b - c,d up to 2020/21 - d UV lamp
105	059078	0694502400	Filter (L.C)	Filtro elettrico 411.5.24.41.0D (TIPO L-C)	c,d from 2020/22
106	093848	0648R06300	Relay 66.82.8.230.0001	Relè 66.82.8.230.0001	
107	095984	0546401600	Clip for board	Distanziale per scheda	
108	096312	0514R29600	Electric box filter	Filtro scatola elettrica	a,b,c,d 50 Hz
109	0CA716	0682400300	Assial fan 92x25	Ventilatore assiale 92x25	Up to 2020/21
110	096209	0648R11100	Relay 50A + heat sink	Relè con dissipatore 50A	
111	096010	0648R08602	ACU PETRA BCF	Scheda principale PETRA	Up to 2020/19 canceled
111	096557	0648R10900	ACU PETRA BCF	Scheda principale PETRA	From 2020/21
112	095639	0648R10000	Main board power supply 12V 30W	Scheda principale di potenza 12V 30W	a,b,c,d
112	096342	0648R11400	Main board power supply 12V 54W UL	Scheda principale di potenza 12V 54W	e
113	095933	0652R02400	Glass fuse 10A T 5x20	Fusibile in vetro 5X20	
113	0L3083	0652608900	Fuse 10A T 5x20 250V	Fusibile ceramico 5X20	a,b, 60Hz - e
114	091725	640R01000	Ausiliary contactor HK-11	Contatto ausiliario per slavamotore HK-11	
115	093950	624R01600	Electronich power UV light 188700	Alimentatore elettronico per UV lampada	for UV lamp
115	097536	0624R00J00	Electronich power UV light 188700	Alimentatore elettronico per lampada UV	e for UV lamp
116	0CK685	083040PG01	Ass. TOUCH UI ELUX predisposed with ethernet direct connection	Pannello completo UI predisposto con connessione ethernet	
117	0CK030	0546400U00	Drawer slot USB	Ckm sede per Usb	
118	0CK031	0543401P02	Gasket drawer slot USB	Guarnizione per sede supporto USB	
119	0CK032	0514405000	Spring drawer slot USB	Molla per sede supporto USB	
120	0CK432	0506405M00	Hook/support for Cmk Touch UI	Gancio per pannello di controllo	
121	0CK033	0675401G00	CKM ON/OFF board	Scheda ON/OFF	
125	0CK045	0675401Q00	CKM ON/OFF board wiring	Cavetto scheda ON/OFF	
126	0CK330	0675401L00	Speaker wiring	Cavetto speaker	
127	0CK039	0655400000	Speaker 4 ohm	Speaker 4 ohm	
128	0CK040	0543401N01	Plastic frame touch	Pannello in plastica touch	
129	0CK041	0546400V00	Cover slot USB	Sportello USB	
130	095934	0755R13902	Adhesive decor Electrolux	Membrana Electrolux	electrolux
130	095935	0755R16103	Adhesive decor Zanussi	Membrana Zanussi	zanussi
130	095936	0755R16202	Adhesive decor Alpeninox	Membrana Alpeninox	alpeninox
130	0CK332	0541401V02	Adhesive decor To brand	Membrana To brand	to brand
131	0CK161	0541401D01	Protection comand panel	Copertura pannello comandi touch	

Pos	Code	Factory code	Description	Descrizione	Ref/notes
132	0CK042	0875406301	WI Board /NIU	WI Board /NIU	
133	0CK037	0638404D00	USB wiring L 450 mm	Cavo USB L450 mm	
134	096412	0640R00000	Diagnose Kriwan switch INT69-2CB	Modulo Kriwan INT69-2CB-DIAGNOSE	
135	097255	0515R45600	CU pipe evaporator to thermostatic valve	Tubo evaporatore-valvola termostatica	c,d CO2
136	097020	0515R45101	Inlet pipe for thermostatic valve	Tubo ingresso valvola termostatica	c,d CO2
137	097254	0505R08U00	Support for mini EVD	Supporto per mini EVD	c,d CO2
138	097031	0646R06K01	Pressure sensor 90 bar	Sensore pressione 90 bar	c,d CO2
139	097260	0646R06J00	Thermostatic valve	Valvola di espansione elettronica	c,d CO2
140	097034	0805R00L01	Unipolar stator	Statore unipolare da 1m per e2v%u	c,d CO2
141	097032	0646R06L01	Sensor ntc hf l=1.80mt	Sensore ntc hf l=1.80mt	c,d CO2
142	097027	0634R01S01	Cable awg 3 wires L=2m for pressure sensor	Cavo AWG per sensore di pressione L=2m	c,d CO2
143	097033	0648R02A01	Driver EVD mini 115/230v with display	Driver EVD mini 115/230v con display	c,d CO2
144		0805R00X00	Pipes subassembly	Assieme tubi	c,d CO2
145	093946	0559R01800	Front gasket	Guarnizione lampada	e with UV lamp
146	093948	0665R01100	UV support	Supporto lampada	e with UV lamp
147	097657	0835R33T00	KIT UV LAMP RECOVERY	KIT UV LAMP RECOVERY	UV lamp from 2022/29 - See Tech. Sheet VTX2022_02
148			BATTERY CR2032 V3 LITIO	BATTERIA MODELLO CR 2032 V3 LITIO	
149	0CK674	675403M00	MICRO SD 4G o more biger 4HC	MICRO SD 4G o piu' grande 4HC	
*	097122	0878R08800	Fan Motor Operation conversion KIT		

Electrolux Professional SpA
Viale Treviso, 15
33170 Pordenone, ITALY
Fax (+39) 0434 380 201
<https://www.electroluxprofessional.com>
<https://webgate.electroluxprofessional.com>

Finanzen / Service
28307 Bremen
Thalendorststraße 15
Tel.+49 421 48557-0
Fax+49 421 488650
bremen@nordcap.de

Vertrieb Ost
12681 Berlin
Wolfener Straße 32/34, Haus K
Tel.+49 30 936684-0
Fax+49 30 936684-44
berlin@nordcap.de

Vertrieb West
40699 Erkrath
Max-Planck-Straße 30
Tel.+49 211 540054-0
Fax+49 211 540054-54
erkraht@nordcap.de

Vertrieb Nord
21079 Hamburg
Großmoorbogen 5
Tel.+49 40 766183-0
Fax+49 40 770799
hamburg@nordcap.de

Vertrieb Süd
55218 Ingelheim
Hermann-Bopp-Straße 4
Tel.+49 6132 7101-0
Fax+49 6132 7101-20
ingelheim@nordcap.de



www.nordcap.de