

Ersatzteilliste-Explosionszeichnung

Gärvollautomat GV 600

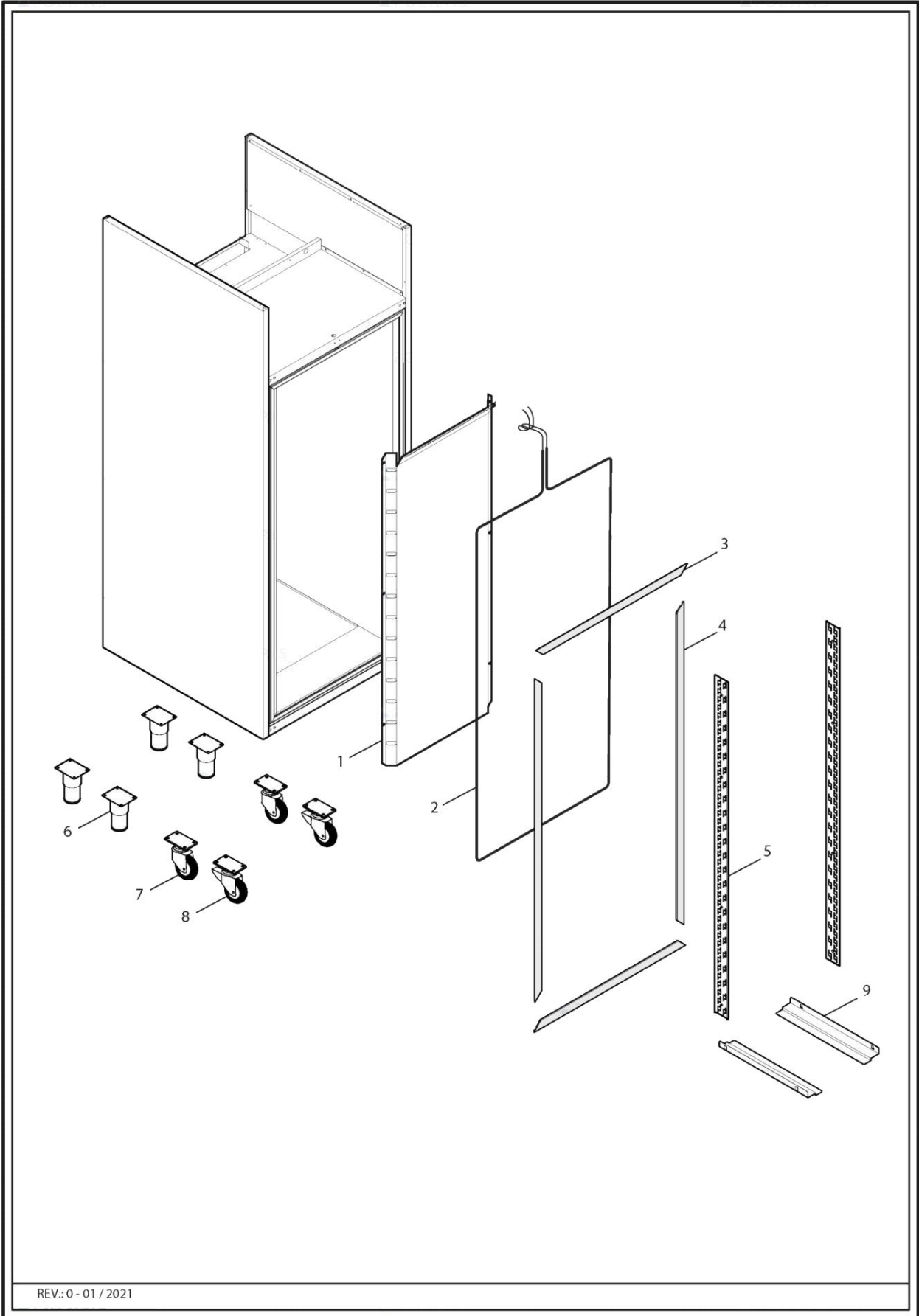



Pos	Art.- Nr.	Bezeichnung	Anmerkungen	Gültig ab:	Gültig bis:
0001	BN33811000	SCHIENA CELLA EN-ICE 304 '19	SCHIENA CELLA EN-ICE 304 '19		
0002	BN16660500	RES.COR. L=7080 7 W/M 1P.INT.AR EN'19	RES.COR. L=7080 7 W/ M 1P.INT.AR EN'19		
0003	BN1471130728	PROF.CORN. ORIZ.SCOCCA EN-ICE '19 L= 728	PROF.CORN. ORIZ.SCOCCA EN-ICE '19 L= 728		
0004	BN1471131574	PROF.CORN. VERT.SCOCCA EN-ICE '19 L=1574	PROF.CORN. VERT.SCOCCA EN-ICE '19 L=1574		
0005	BN33581000	MONTANTE GUIDE A L/C EN1-EN2 RIP '19	MONTANTE GUIDE A "L"/"C" EN1- EN2 RIP '19		
0006	BN1467590	ASS. PIEDINO 2" TONDO H=115-170 ARMADI	ASS. PIED. 2" TONDO H= 97-159 AREN'19		
0007	BN147805	RAD DURCHMESSER 100 ROLLE DURCHMESSER 100	RUOTA 100 Polid. PIASTRA		
0008	BN147806	RAD DURCHMESSER 100 MIT BREMSE ROLLE DURCHMESSER 100 MIT BREMSE	RUOTA 100 Polid. PIASTRA/ FRENO		
0009	FR1231110	L-FÖRMIGE AUFLAGSCHIENE [R] TABLETTE AR EN2 L. 730	GUIDA A 'L' DA 730 PER TEGLIE AR EN2		

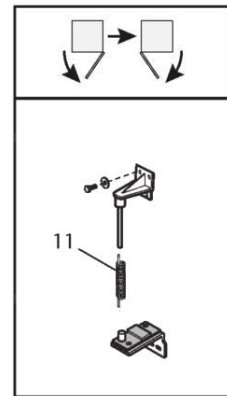
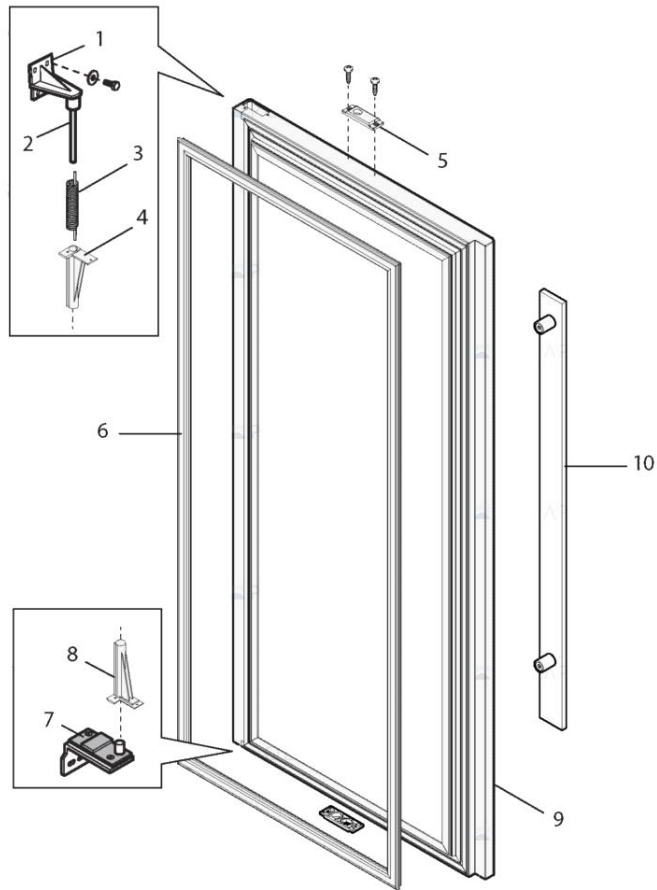

Pos	Art.- Nr.	Bezeichnung	Anmerkungen	Gültig ab:	Gültig bis:
0001	BN32215160	UNTERE LINKE/OBERE RECHTE SCHARNIER KIT [R]	STAFFA SUPERIORE SUT P.C. V.02		
0002	BN146616070	STIFT [R] TRAGBÜGEL NEW	PERNO PER STAFFESUT NEW		
0003	BN1412083	FEDER RECHTS FÜR CNS-SCHRANKTÜR	MOLLA DESTRA PORTE PANN. ARMADI		
0004	FR4750920	PINOLE [R]	CANOTTO IN PLASTICA SUPERIORE DX		
0005	FR4710901	GEGENSTÜCK FÜR SCHLOSS	SUPPORTO MAGNETE E SERRATURA		
0006	BN14416871533	GUARN. 1533X 687 PORTA EN-ICE '19	GUARN. 1533X 687 PORTA EN-ICE '19		
0007	BN32215150FAN	CERNIERA INF.DX PIEGATA C/FERMO AR.EN'19	STAFFA INFERIORE SUT P.C. V.02		
0008	FR4750930	PINOLE [R]	CANOTTO IN PLASTICA INFERIORE DX		
0009	BN32632600	BOM.PORT.INT. DX POL EN'19-++++dm3	BOM.PORT.IN T. DX POL EN'19		
0010	BN32140580	ASS. MANIGLIA PORTA INT POL SUTCLA EN'19	ASS. MANIGLIA PORTA		
0011	FR3410550	FEDER LINKS FÜR CNS-SCHRANKTÜR	MOLLA SINISTRA PORTE PANN. ARMADI		

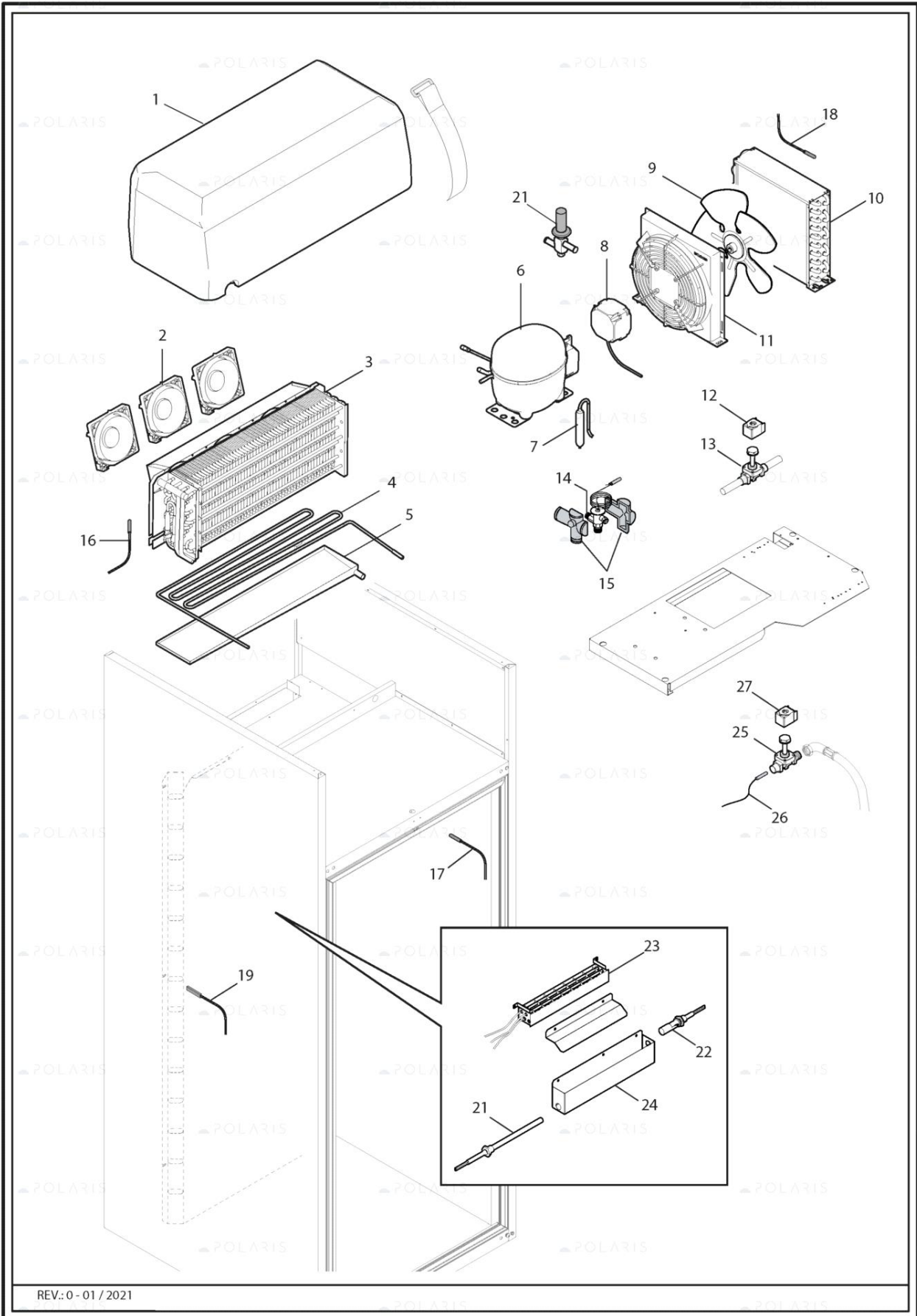

REV.: 0 - 01 / 2021

Pos	Art.- Nr.	Bezeichnung	Anmerkungen	Gültig ab:	Gültig bis:
0001	BN14251000	CAMPANA POLISTIROLO	EN-ICE '19		CAMPANA POLISTIROLO EN-ICE '19
0002	BN16481252200	VENT.NMB125x125 37 0,17A12VDC L=2000			VENT.NMB125 x125 37 0,17A12VDC
0003	BN143301600	EVAPORATORE EN1-2 TNN-BT/ICE 3RD7 '19 UL			EVAPORATOR E EN1-2TNN
0004	BN16660630	ABTAUHEIZELEMENT [R] 120W AR FL'20			RES.EVAPORA ZIONE ACQUA 120W
0005	BN321490440	KIT BAC.SCAR.+RES.+TUBO PVC ENBT-ICE '21			BACINELLA SCAR.EVAP.IN OX
0006	BN14151420770	COMPR NEU2178U CSR R290 220-240/50			COMPR. EMB NEU2178U CSR R290 220-240/50
0007	FR6520472	TROCKNERFILTER 025GR E=6 U=6 XH9			ASSIEME FILTRO 25 GR EN2 BT
0008	BN1648007200	MOTOR ECO072 H.12m 230V FS1300rpm.3,2mt			MOTORE NiQ3212-330 450- V48.12-193 25W240V
0009	BN1495230028	AXIALL?FTER A 230 28?			VENTOLA ELIC. A 230 28° ASPIR
0010	BN141622800033	VERFLUESSIGER [R] 10T 5R 5/16			COND.ARIA10 T5R 5/16"- SUT140BT
0011	BN1417005	CONVOGLIATORE IN PLASTICA COND.CG200 EXT			CONVOGLIAT ORE IN PLASTICA CONDENS. CG230
0012	FR6851142	SPULE MQ-A0322G-000001 220/240V 50/60H			BOBINA MQ- A0322G-0000 01 220/240V 50/60HZ
0013	FR6850332	MAGNETVENTIL 6MM [R]			VAL.SOLEN.M DF08021 6MM MDF A03-3H005
0014	BN14970600	VALV.TER.DANF.TUB 068U3712 6X12 R290			VALV.TER.DA NF.TUB 068U3712 6X12 R290
0015	BN144551	ISOLIERUNG F?R THERMOSTATVENTIL			ISOLAMENTO VALVOLA THERMOSTATI CA
0016	BN167277	SONDA NTC TPE CONN. JST RED EVTPNW15F200			SONDA NTC 2.0 MT ROSSA EVAPORATOR E
0017	BN167268	Sonda NTC 1.5 MT cavo TPE			SONDA NTC 2.0 MT BLU CELLA

Pos	Art.- Nr.	Bezeichnung	Anmerkungen	Gültig ab:	Gültig bis:
0018	BN167263	RAUMFUEHLER [R] NTC 1.5 MT			
			SONDA NTC 1.5 MT GIALLA COND		
0019	BN321490400	ASS.SONDA UMID.+PROT.SONDA AREN-TAVEN'21			
0020	FR6860160	DR.EINST. SPORLAN CRO-4-0/75 1/2X1/2 ODF			
			REG.PRES.SP ORLAN CRO-4-0/75 1/2X1/2 ODF		
0021	FR6621950	HEIZELEMENT [R] 190W AUFEUCHTER			
			RESIST. 190W UMIDIF. AL- TL-A		
0022	BN1681440	LIVELLOST. EUROSITCH P500+100°C JST XHP			
			LIVELLOST. EUROSITCH P500+100°C		
0023	FR6621190	HEIZELEMENT [R] 1000W 230V			
			RESISTENZA H25 3C VT27 230V 500+500W		
0024	BN33106330	BACINELLA UMIDIFICAZIONE FL '20			
			BACINELLA UMIDIFICAZI ONE		
0025	FR6860020	MAGNETVENTIL W-W WASSER 3/8'			
			VALV. SOL. 1132/03S F-F ACQUA 3/8"		
0026	BN1415601042	CAPILLARE 2.5x4.0 mm CAR.H2O (X RICAMBI)			
			CAPILLARE D=1.24 X 2100 CARICO ACQUA		
0027	FR6851140	MAGNETVENTILSPULE [R] 230V 50/60HZ			
			BOBINA HF2 9300/RA6 230V 50/60HZ		

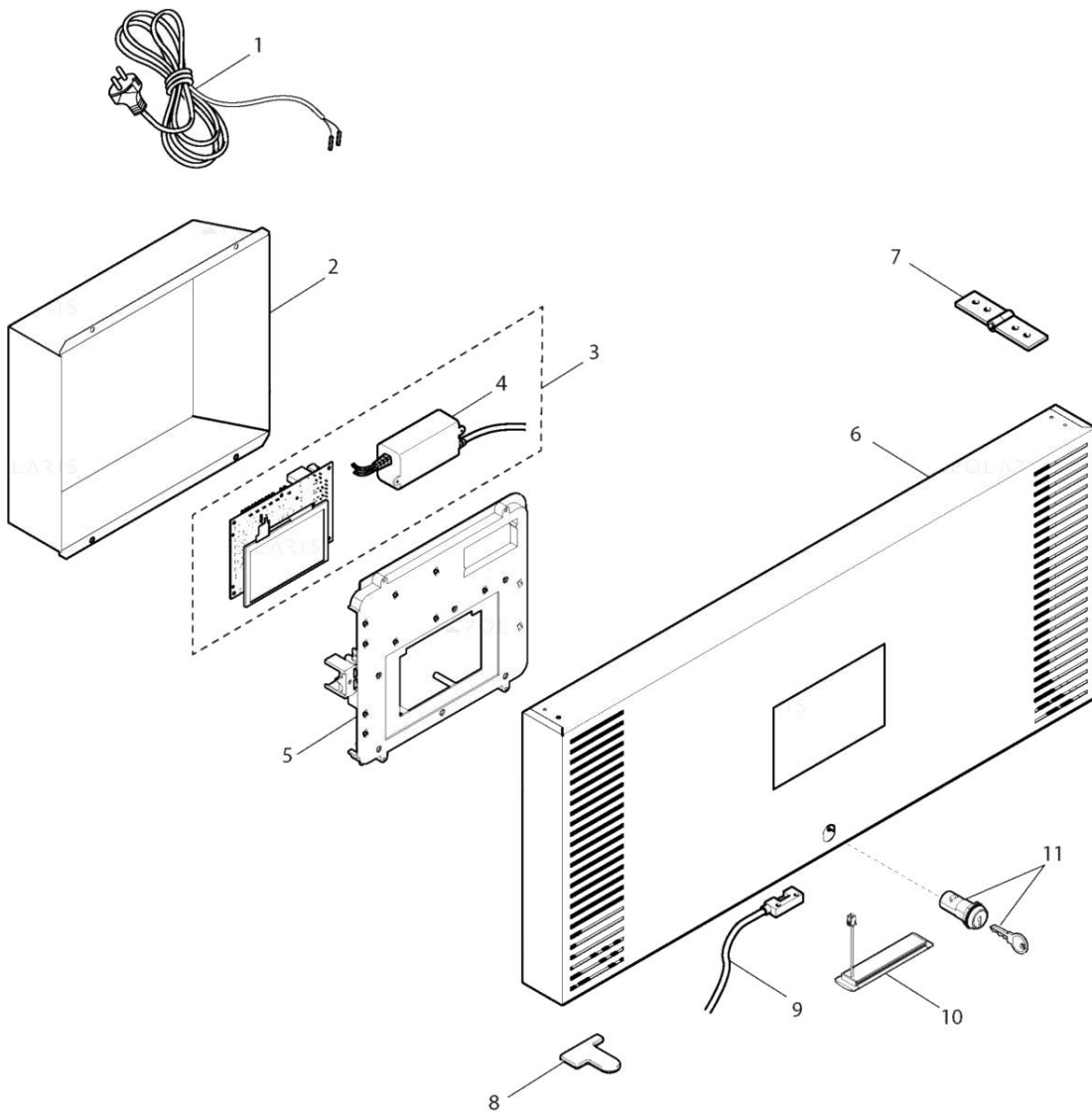

Pos	Art.- Nr.	Bezeichnung	Anmerkungen	Gültig ab:	Gültig bis:
0001	BN16101565	CAVO ALIM.3X1.5 L=4000 SP.SCHUKO SCH.CJB	CAVO ALIM.3X1.5 L=4000 SP.SCHUKO SCH.CJB		
0002	BN33651030	PROT. SCHEDA CRUSCOTTO EN-ICE'19	PROT. SCHEDA CRUSCOTTO EN-ICE'19		
0003	BN1681390	ASS.SCHEDA CONTROLLO 7 PIGGY FL-MAXI'20	ASS.SCHEDA CONTROLLO 7" PIGGYFL- MAXI'20		
0004	BN168340	TRANSFORMATOR AC/DC APV-16E-12DI-16W 12V	TRASF. AC/ DC APV-16E-12D I-16W 12V L=330		
0005	BN33604010	PIASTRA C/CYCAT.SUPP.SCHEDA 7FL-MAXI'20	PIASTRA C/ CYCAT.SUPP. SCHEDA 7"FL- MAXI'20		
0006	BN33283400	CR.FL-AS POL 304 L= 790 '20	CR.FL-AS POL 304 L= 790 '20		
0007	FR936041	SCHARNIER [R]	CERNIERA BISCOTTO ACC.ZN .MM 15X100		
0008	BN1489330	TAPPO CRUSCOTTI ARMADI EN-ICE'19*nota	TAPPO CRUSCOTTI ARMADI EN- ICE'19*nota		
0009	BN1646100	MICRO E510+CONNET.JST XHP2 L800 AR EN'19	MICRO E510+CONNE T.JST XHP2 L800 AR EN'19		
0010	BN165885	LED LEISTE 06 LED 5630 12V 3W [C]	STRISCIA 06 LED 5630 12V 3W KEY-LUX BIAN		
0011	FR935400	935400 SERRATURA A CHIAVE	SERRATURA CHIAVE BOX CAVO LUNGO L=46		

Finanzen/Service
28307 Bremen
Thalenhorststraße 15
Tel.+49 421 48557-0
Fax+49 421 488650
bremen@nordcap.de

Vertrieb Ost
12681 Berlin
Wolfener Straße 32/34, HausK
Tel.+49 30 936684-0
Fax+4930936684-44
berlin@nordcap.de

Vertrieb West
40699 Erkrath
Max-Planck-Straße 30
Tel.+49 211 540054-0
Fax+49 211 540054-54
erkrath@nordcap.de

Vertrieb Nord
21079 Hamburg
Großmoorbogen 5
Tel.+49 40 766183-0
Fax+49 40 770799
hamburg@nordcap.de

Vertrieb Süd
55218 Ingelheim
Hermann-Bopp-Straße 4
Tel.+49 6132 7101-0
Fax+49 6132 7101-20
ingelheim@nordcap.de



www.nordcap.de