

## Ersatzteilliste-Explosionszeichnung

Schnellkühler / Schockfroster SF 40/25-CW CRIO CHILL



# SPARE PARTS CATALOGUE

**CROSSWISE 40KG 10GN 1/1**

## CHILLER FREEZER

PNC	MODEL	REF.	PAG.	DESCRIPTION	NOTE/BRAND
110921	ZCBCFA040SE	a	3-6	BLAST CHILLER/FREEZER 40KG 10 GN 1/1 - R452A	ZAN
110922	ZCBCFA040SB	b	3-6	BLAST CHILLER/FREEZER 40KG 10 GN 1/1 - R452A - 60HZ	ZAN
725214	ECBCFA040SE	c	3-6	BLAST CHILLER/FREEZER 40KG 10 GN 1/1 - R452A	EPR
725216	ECBCFA040SB	d	3-6	BLAST CHILLER/FREEZER 40KG 10 GN 1/1 - R452A - 60HZ	EPR
725409	GCBCF40SA	e	3-6	BLAST CHILLER/FREEZER 40KG 10 GN 1/1 - R452A - 60HZ - 220-240V	Engefood
729535	MCBCFA040SE	f	3-6	BLAST CHILLER/FREEZER 32/28KG 10 GN 1/1 - R452A	To brand
729542	ACBCFA040SE	g	3-6	BLAST CHILLER/FREEZER 40KG 10 GN 1/1 - R452A	Alpeninox

## INDEX - INDICE

## PAG.

CABINET AND DOOR	3
SPARE PART LISTS - CABINET AND DOOR	4
COOLING UNIT AND CONTROL PANEL	5
SPARE PART LISTS - COOLING UNIT AND CONTROL PANEL	6-7

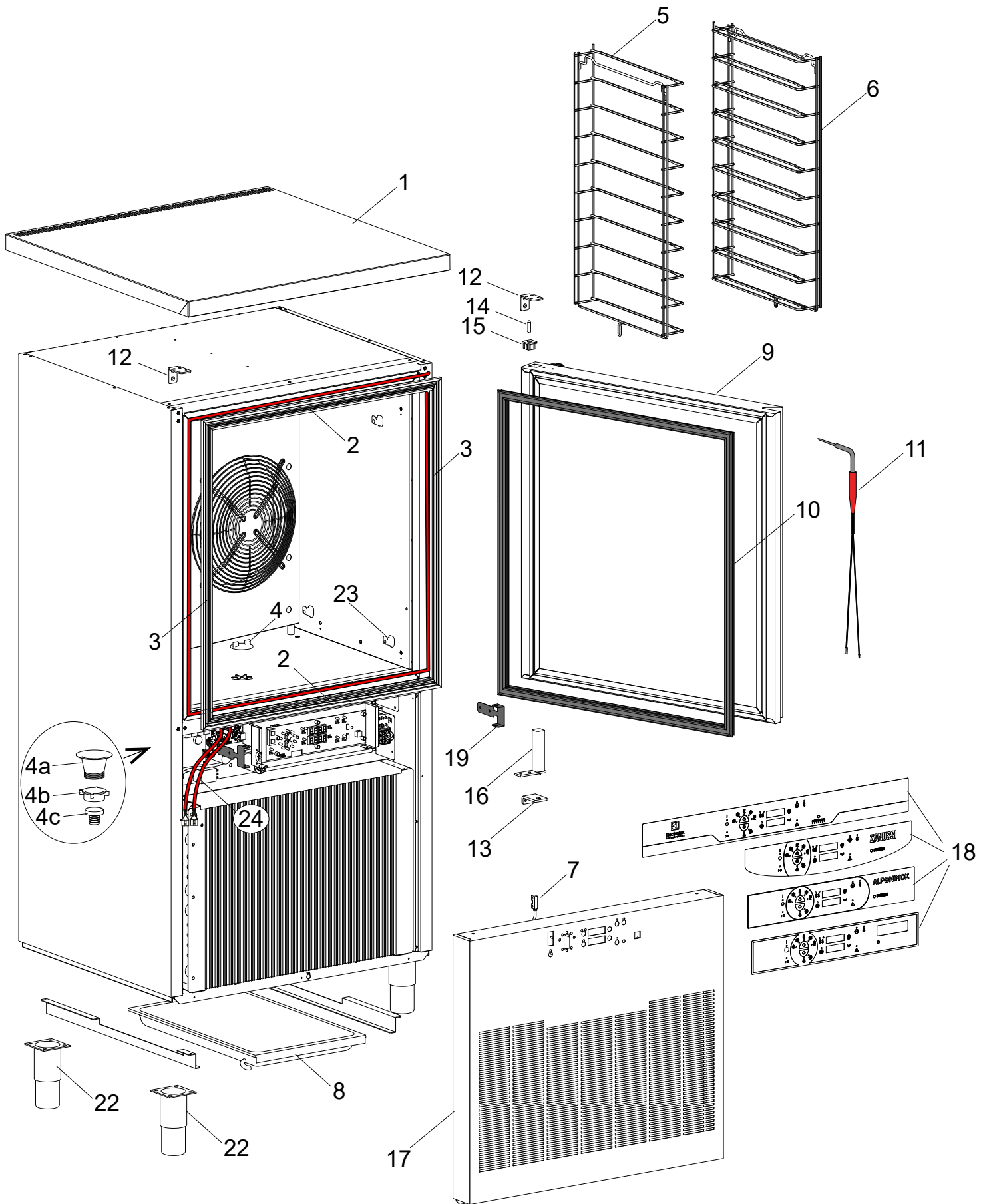

## CABINET AND DOOR

From Ser. Nr.  
Up to Ser. Nr.

Ed. 01 2023-03  
Ed. 01 2023-03

Page: 3

@

Doc No:595R07J00

POS	FACTORY CODE	S.P. CODE	DESCRIPTION	V	W&T	REF.	NOTES	S/N BREAK (YYYY/WK)
1	0830774805	085759	Top for freestanding appliance		x			
2	0505781301	092883	Horizontal frame	x				
3	0505783101	090003	Vertical frame	x				
4	0546R27300	093934	Plug for pipe		x			
4a	0546R25400	094255	Discharge pipe		x			
4b	0546R26900	094257	Nut		x			
4c	0546R26200	094256	Rubber support for pipe		x			
5	0514R31401	097678	Left shelf rack	x				
6	0514R31501	097679	Right shelf rack	x				
7	0640R00D00	097671	Door microswitch	x				
8	0242452410	080803	Water condenser basin		x			
9	0875R06L01	097699	Door assembly	x				
10	0543750202	083397	Door gasket	x				
11	0646R06Z00	097682	One sensor food probe	x				
12	0506753502	085754	Upper hinge door	x				
13	0506753604	085755	Lower hinge door	x				
14	0506717801	0A9124	Door hinge pin	x				
15	0544709200	083875	Door hinge bush	x				
16	0835714501	083876	Door hinge lowered pin	x				
17	0805R01G02	097687	Control panel without components		x	c; d	EPR	
17	0805R01H01	097688	Control panel without components		x	a; b; e; f; g	ZAN, APX, TO BRAND	
18	0755R16800	097668	EPR control sticker	x		c; d	EPR	
18	0755R16900	097667	ZAN control sticker	x		a; b	ZAN	
18	0755R17001	097683	APX control sticker	x		g	APX	
18	0755R17100	097666	To brand control sticker	x		e, f	TO BRAND	
*	0755R17200	097684	Logo for Engefood sticker	x		e	Engefood	
19	0512773002	097672	Control panel support		x			
22	0855631900	048579	Feet	x				
23	0546703802	083878	Hook racks support	x				
24	0617713304	084724	Heating cable		x			

## SPARE PARTS CODE - CABINET AND DOOR

\* On demand

**Bold=last change**

From Ser. Nr. Up to Ser. Nr.	Ed. 01 2023-03 Ed. 01 2023-03	Page: 4	<b>Doc No:595R07J00</b>
---------------------------------	----------------------------------	---------	-------------------------

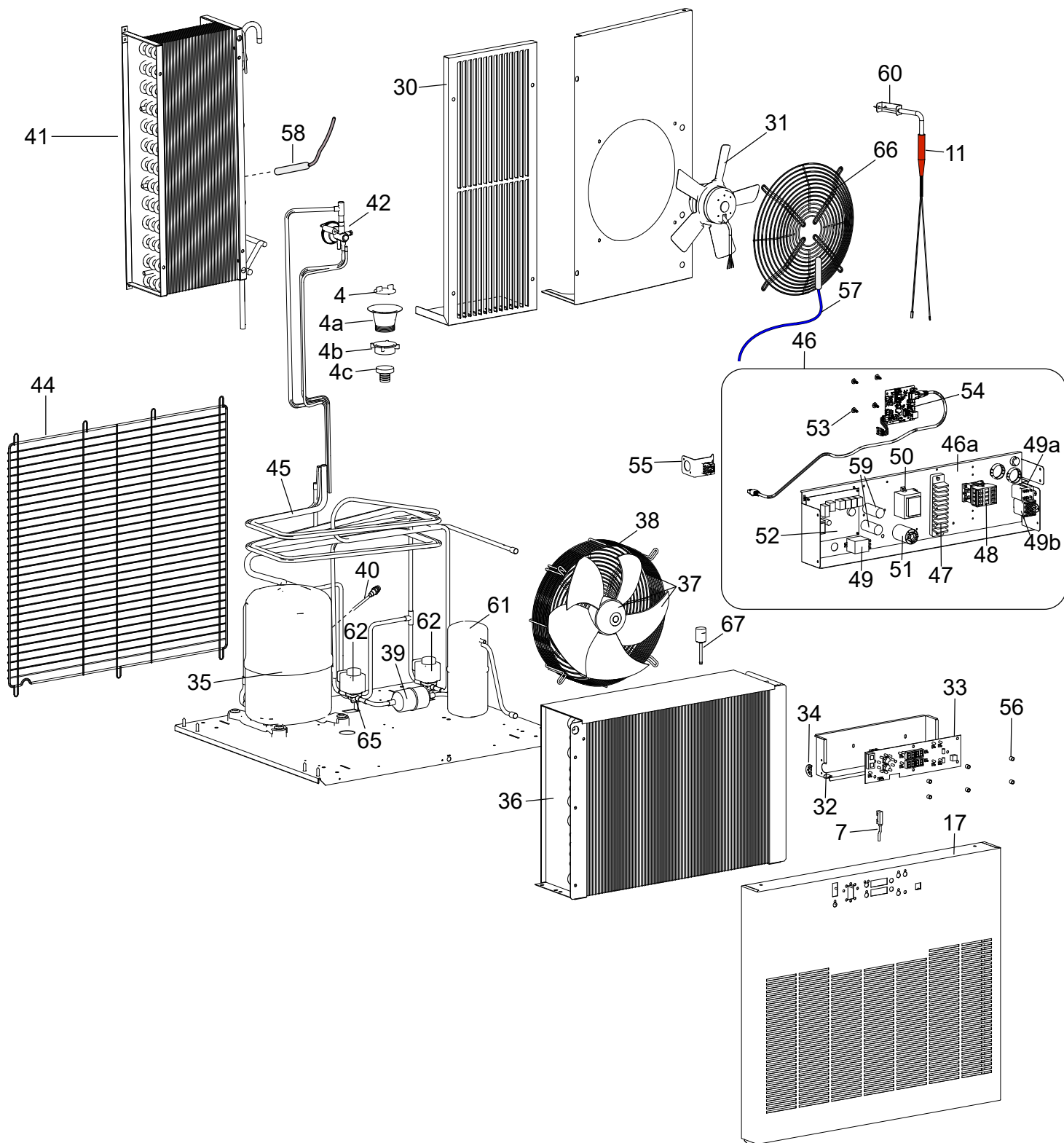

## COOLING UNIT AND CONTROL PANEL

From Ser. Nr.  
Up to Ser. Nr.

Ed. 01 2023-03  
Ed. 01 2023-03

Page: 5 @

Doc No:595R07J00

POS	FACTORY CODE	S.P. CODE	DESCRIPTION	V	W&T	REF.	NOTES	S/N BREAK (YYYY/WK)
30	0504R01U00		Evaporator carter		x			
31	0857796200	088624	Fan evaporator assembly	x				
32	0504R37400	097670	User board protection		x			
33	0648R02M00	097726	User board	x				
34	0639R23600	097673	Grommet	x				
35	0684R15900	097620	Compressor TECUMSEH	x		a; c; f; g	50 Hz	
35	0684R16000	097621	Compressor TECUMSEH	x		b; d; e	60 Hz	
36	0830797603	088625	Gas condenser	x				
37	0856R26200	094830	Motor fan condenser ELCO 230-240V/50-60 HZ assembly	x				
38	0514R09700	092853	Protection fan condenser	x				
39	0805747600	087438	Filter DML052 S	x				
40	0845713000	085505	Schrader filling valve H42	x				
41	0845721203	088627	Evaporator	x				
42	0646754601	088475	Thermostatic valve/Expansion valve	x				
44	0541716703	088619	Back grid	x				
45	0805R01Q01	097689	Pipe exchanger	x				
46	0855R0A501	097697	Electric box assembly	x				
46a	0510781103	097669	Electric box	x				
47	0855R09S01	097693	Clamp with wiring	x				
48	0648807300	088477	Contactora 220-230 50 hz	x		a; c; f; g	50 Hz	
48	0648729200	099090	Contactora 240 60hz	x		b; d; e	60 Hz	
49	0648802701	056510	Relay Finder 24 V	x				
49a	0648703800	083215	Relay Finder 60.62.8.230	x				
49b	0648725400	088197	Relay RA	x				
50	0624711702	087662	Voltage adaptor 230/24 V	x				
51	0694700800	084987	Filter LC		x			
52	0648R04902	093125	Main board	x				
53	0546401600	095984	Main board spacer	x				
54	*	*	Lion board connectivity		x			
55	*	*	Connectivity bracket LAN cable		x			
56	0546R08D00	097674	Round spacer Ø 6,2 ; EX 9,0	x				
57	0646R07200	092177	Blu cell probe	x				
58	0646R12000	093531	Gray evaporator probe	x				
59	0648729500	090089	Capacitor 5 UF UL-CSA	x				
59	0648730000	096009	Capacitor 3 UF UL-CSA	x				
60	0506748800	089860	Food probe support	x				
61	0805725501	083403	Liquid receiver	x				
62	0646749000	088351	Coil for solenoid valve	x				
65	0646723000	084085	Solenoid valve	x				
66	0514752001	088623	Motor fan grid	x				
67	646R20300	096201	Pressure switch for high pressure	x				

## SPARE PARTS CODE - COOLING UNIT AND CONTROL PANEL

\* On demand

**Bold=last change**

From Ser. Nr. Up to Ser. Nr.	Ed. 01 2023-03 Ed. 01 2023-03	Page: 6	<b>Doc No:595R07J00</b>
---------------------------------	----------------------------------	---------	-------------------------

\* On demand

**Bold=last change**

From Ser. Nr.  
Up to Ser. Nr.

Ed. 01 2023-03  
Ed. 01 2023-03

Page: 7

**Doc No:595R07J00**



Electrolux Professional SpA  
Viale Treviso, 15  
33170 Pordenone, ITALY  
Fax (+39) 0434 380 201  
<https://www.electroluxprofessional.com>  
<https://webgate.electroluxprofessional.com>

**Finanzen / Service**  
**28307 Bremen**  
Thalendorststraße 15  
Tel.+49 421 48557-0  
Fax+49 421 488650  
bremen@nordcap.de

**Vertrieb Ost**  
**12681 Berlin**  
Wolfener Straße 32/34, Haus K  
Tel.+49 30 936684-0  
Fax+49 30 936684-44  
berlin@nordcap.de

**Vertrieb West**  
**40699 Erkrath**  
Max-Planck-Straße 30  
Tel.+49 211 540054-0  
Fax+49 211 540054-54  
erkrath@nordcap.de

**Vertrieb Nord**  
**21079 Hamburg**  
Großmoorbogen 5  
Tel.+49 40 766183-0  
Fax+49 40 770799  
hamburg@nordcap.de

**Vertrieb Süd**  
**55218 Ingelheim**  
Hermann-Bopp-Straße 4  
Tel.+49 6132 7101-0  
Fax+49 6132 7101-20  
ingelheim@nordcap.de



[www.nordcap.de](http://www.nordcap.de)