

FRIGORIFERO DIGITALE

LEGENDA

- B1: INTERUTTORE GENERALE
- B2: MICRO PORTA
- B3: ALLARME APERTURA PORTA
- M1: COMPRESSORE
- M2: VENTILATORE CONDENSATORE
- M3: VENTILATORE CELLA
- MP: TERMOREGOLATORE DIGITALE
- S1: SONDA CAMERA
- U1/U2: TRASFORMATORE 230V/12V

DIGITAL REFRIGERATOR

LEGEND

- B1: MAIN SWITCH
- B2: DOOR SWITCH
- B3: OPENING DOOR ALARM
- M1: COMPRESSOR
- M2: CONDENSER FAN
- M3: STORAGE COMPARTMENT FAN
- MP: DIGITAL THERMOREGULATOR
- S1: ROOM PROBE
- U1/U2: TRANSFORMER 230V/12V

With B1 Connection:

- Terminal "C": Brown wire from power cord
- Terminal "-": Blue wire from power cord
- Terminal "+ and NO": Black wires to THERMOSTAT Pin 6

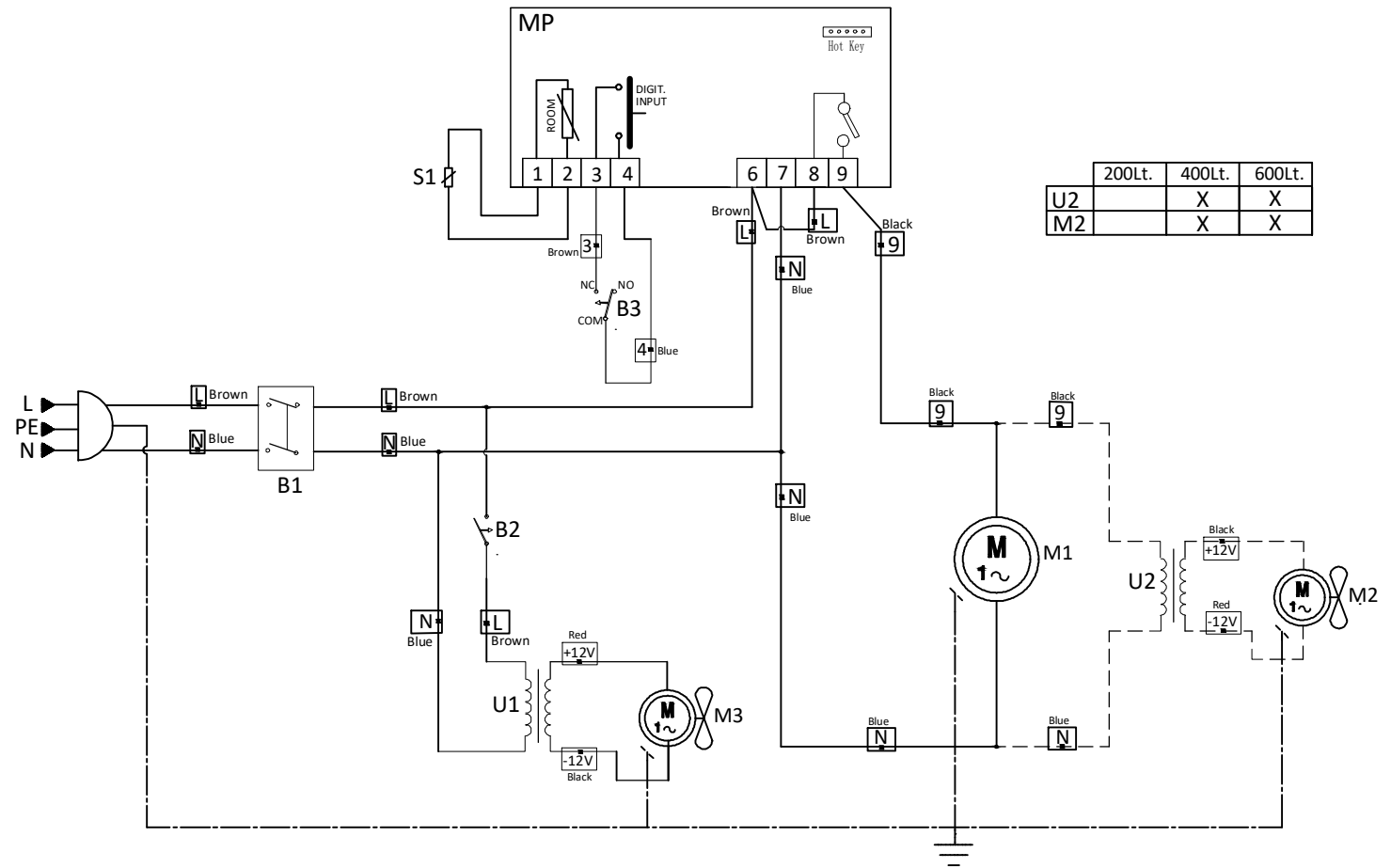
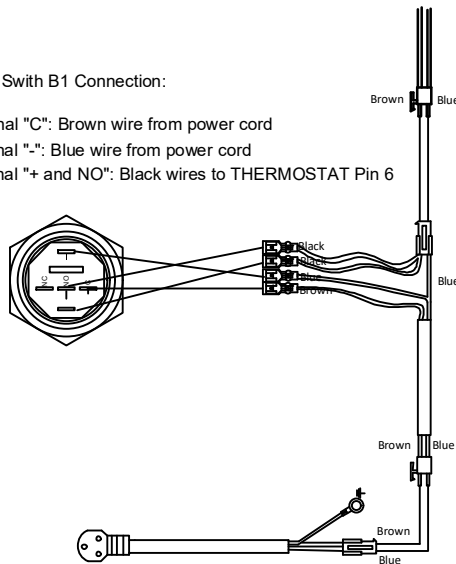

	200Lt.	400Lt.	600Lt.
U2		X	X
M2		X	X